

brother

自動本縫玉縁機

自動本縫玉縁機 <フラップ付用>

AUTOMATIC LOCKSTITCH POCKET WELT SEWER

AUTOMATIC LOCKSTITCH POCKET WELT SEWER <FOR FLAP ATTACHMENT>

AUTOMATISCHE STEPPSTICH-NÄHMASCHINE ZUM EINFASSEN VON TASCHEN

AUTOMATISCHE STEPPSTICH-NÄHMASCHINE ZUM EINFASSEN VON TASCHEN

<ZUM AUFNÄHEN VON KLAPPEN>

OURLEUR AUTOMATIQUE DE POCHE AU POINT DE NAVETTE

OURLEUR AUTOMATIQUE DE POCHE AU POINT DE NAVETTE

<ATTACHANGE DES PATTES>

MÁQUINA DE COSER AUTOMÁTICA PARA EL RIBETEADO DE DOBLE PESPUNTE DE BOLSILLOS

MÁQUINA DE COSER AUTOMÁTICA PARA EL RIBETEADO DE BOLSILLOS

CON DOBLE PESPUNTE <PARA COLOCACIÓN DE SOLAPAS>

BAS-610 BAS-611

PICK LOCATION
03W152-418

ORDER: 240333



QUANTITY

1

EA

0

0

CASES
EA

BATCH: 6

DE PIEZAS

PART: 196611201

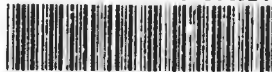

PARTS BOOK

We're at your side.
brother

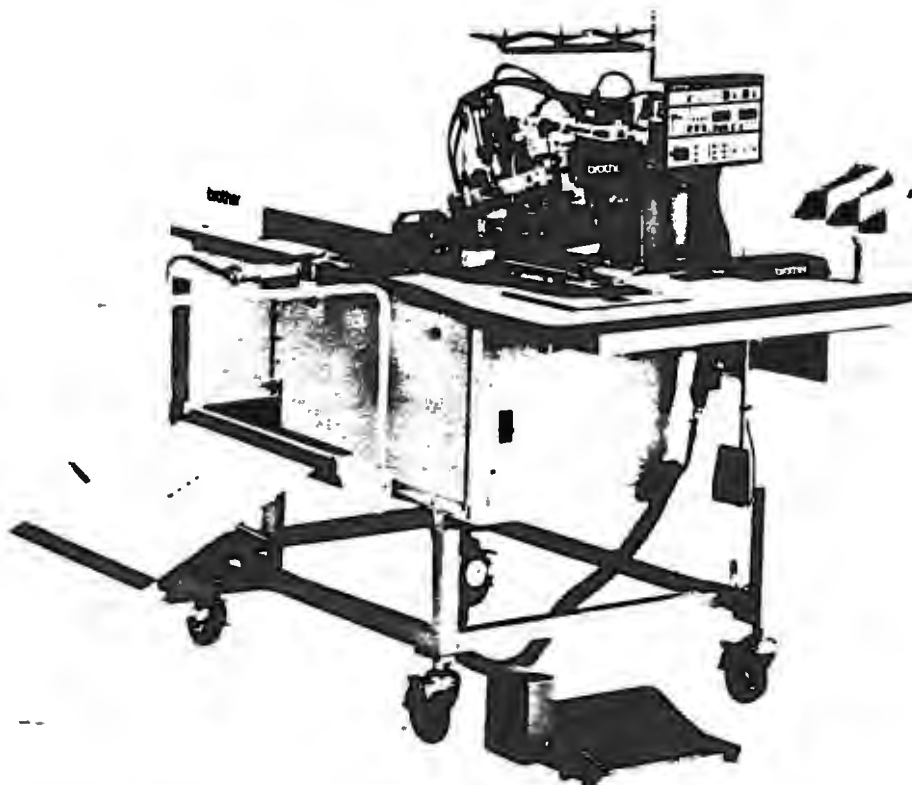

パーツブックご利用に際して

1. 組単位で補給する部品は、 破線で示しております
2. この本は1991年4月のデータに基づいて作成されたものです。
3. 部品は予告なしに設計変更される場合があります。
4. 部品コード欄・RMK 欄が*となっている場合は、ゲージ部品一覧表(86-89ページ)でお調べ下さい。

目 次

A. 主体関係.....	2	R. 布制御関係.....	36
B. 上軸関係.....	2	S. 針位置検出器関係.....	54
C. 針棒揺動関係.....	4	T. ゲージ部品関係.....	54
D. 下軸関係.....	4	U. 踏板関係.....	56
E. メス関係.....	6	V. 動力台関係.....	58
F. カマ関係.....	8	W1. 特別注文部品.....	64
G. 給油潤滑関係.....	10	W2. 特別注文部品(ダーツノバシ).....	66
H. 糸通シ関係.....	14	W3. 特別注文部品(エアージェクター).....	68
J. 糸切れ感知関係.....	16	W4. 特別注文部品(下送り装置).....	68
K. スタッカー関係.....	18	X. 特別注文部品(立ちペダル).....	70
L. 糸巻関係.....	26	Z1. 付属品関係(自動機付属).....	70
M. 糸切り関係.....	28	Z2. 付属品関係(頭部付属).....	72
N. コントロールボックス関係.....	30	索 引.....	73
P. 空圧関係.....	32	特別注文部品(マーキングライト).....	85
Q. 電装品関係.....	34	ゲージ部品一覧表.....	86

Notes for using this parts book

1. Parts supplied as complete assemblies are circled by a dotted line ().
2. This book was prepared based on information available in April 1991.
3. Parts are subject to changes in design without prior notice.
4. If there is an asterisk in the parts code column, refer to the gauge parts list on page 86 ~ 89.

CONTENTS

A. Machine body	2	S. Synchronizer	54
B. Upper shaft mechanism	2	T. Gauge mechanism	54
C. Needle bar rocking mechanism	4	U. Foot switch pedal mechanism	56
D. Lower shaft mechanism	4	V. Power table	58
E. Knife mechanism	6	W1. Option parts	64
F. Rotary hook mechanism	8	W2. Option parts (Darts stretcher)	66
G. Lubrication	10	W3. Option parts (Air ejector)	68
H. Threading mechanism	14	W4. Option parts (Bottom feed set)	68
J. Thread breakage detector mechanism	16	X. Option parts (Stand pedal)	70
K. Stacker mechanism	18	Z1. Accessories (provided with automatic sewing machine)	70
L. Bobbin winder mechanism	26	Z2. Accessories (provided with machine body)	72
M. Thread trimmer mechanism	28	INDEX	73
N. Control box mechanism	30	Option parts (Marking light)	85
P. Air pressure mechanism	32	GAUGE PARTS LIST	86
Q. Power supply equipment mechanism	34		
R. Cloth control system mechanism	36		

Hinweise zur Verwendung dieser Teileliste

1. Die Teile, die als kompletter Satz geliefert werden, sind mit einer gestrichelten Linie umrandet.
2. Dieses Buch basiert auf den Informationen vom April 1991.
3. Modelländerungen sind vorbehalten.
4. Falls in der Kolonne Teilecode ein Asteriskus vorhanden ist, wird auf die Lehrenteile auf Seite 86 – 89.

INHALTSVERZEICHNIS

A. Maschinengehäuse	2	S. Synchronisator	54
B. Obere welle	2	T. Lehrenvorrichtung	54
C. Nadelstangenbetätigung	4	U. Fußbetätigung	56
D. Untere welle	4	V. Motorgestell	58
E. Messer	6	W1. Sonderzubehör	64
F. Greifervorrichtung	8	W2. Sonderzubehör (Abnäherstrecker)	66
G. Schmierung	10	W3. Sonderzubehör (Luftausstosser)	68
H. Fadenführungsvorrichtung	14	W4. Sonderzubehör (Untertransportsatz)	68
J. Fadenbruchfühler	16	X. Sonderzubehör (Standpedal)	70
K. Anhäufung	18	Z1. Zubehör (mit automatischer Nähmaschine)	70
L. Spuler	26	Z2. Zubehör (mit Nähmaschine)	72
M. Fadenabschneidevorrichtung	28	VERZEICHNIS	73
N. Schaltkasten	30	Sonderzubehör (Markierungsleuchte)	85
P. Luftdruck	32	LEHRENLISTE	86
Q. Stromversorgung	34		
R. Stoffführungsvorrichtung	36		

Notes sur l'utilisation de ce manuel de pièces détachées



1. Les pièces fournies en tant qu'assemblages complets sont encadrées avec un trait pointillé .
2. Ce manuel a été fait d'après les renseignements valables au mois de Avril 1991.
3. Les pièces peuvent être sujettes à des modifications sans préavis.
4. S'il y a un astérisque dans la colonne de code des pièces, se reporter à la liste des pièces calibrées page 86 ~ 89.

TABLE DES MATIERES

A. Corps de la machine 2	S. Synchronisateur 54
B. Mécanisme de l'arbre supérieur 2	T. Mécanisme de jauge 54
C. Mécanisme de balancement de la barre à aiguille 4	U. Mécanisme de la pédale 56
D. Mécanisme de l'arbre inférieur 4	V. Mécanisme du plateau de la machine 58
E. Mécanisme du couteau 6	W1. Pièces en option 64
F. Mécanisme du crocher rotatif 8	W2. Pièces en option (tendeur pour pince) 66
G. Lubrification 10	W3. Pièces en option (éjecteur d'air) 68
H. Mécanisme de l'enfilage 14	W4. Pièces en option (Jeu d'entraînement inférieur) 68
J. Mécanisme du détecteur de cassure du fil 16	X. Pièces en option (Pédale à support) 70
K. Mécanisme de l'emplieur 18	Z1. Accessoires (avec la machine à coudre automatique) 70
L. Mécanisme du bobineur 26	Z2. Accessoires (avec le corps de la machine) 72
M. Mécanisme de coupe-kill 28	INDEX 73
N. Mécanisme du boîtier de contrôle 30	Pièces en option (Lampe de marquage) 85
P. Mécanisme de la pression d'air 32	LISTE DES PIÈCES D'ECARTEMENT 86
O. Mécanisme de l'équipement en alimentation électrique 34	
R. Mécanisme de la système de contrôle du tissu 36	

Notas para usar este Manual de Piezas

1. Las piezas suministradas como conjuntos completos se enmarcan con una línea punteada .
2. Este libro ha sido compilado basándose en los datos de que se disponía en abril 1991.
3. Las piezas quedan sujetas a cambios de diseño sin aviso previo.
4. Para los asteriscos en la columna de código de piezas, consultar la lista de piezas de galga de la página 86 ~ 89.

INDICE

<p>A. Cuerpo de la máquina 2</p> <p>B. Mecanismo del eje superior 2</p> <p>C. Mecanismo de oscilación de la barra de aguja 4</p> <p>D. Mecanismo del eje inferior 4</p> <p>E. Mecanismo del cuchilla 6</p> <p>F. Mecanismo del cangrejo 8</p> <p>G. Lubricación 10</p> <p>H. Mecanismo del enhebrado 14</p> <p>J. Mecanismo del sensor de cortes de hilo 16</p> <p>K. Mecanismo de apilador 18</p> <p>L. Mecanismo del devanador de la canilla 26</p> <p>M. Mecanismo de la cortadura de hilos 28</p> <p>N. Mecanismo de la caja de controles 30</p> <p>P. Mecanismo de la presión de aire 32</p> <p>Q. Mecanismo del equipo de alimentación de corriente 34</p> <p>R. Mecanismo de la sistema de control de tela 36</p>	<p>S. Sincronizador 54</p> <p>T. Mecanismo del galga 54</p> <p>U. Mecanismo del pedal 56</p> <p>V. Mecanismo de la mesa de la máquina 58</p> <p>W1. Piezas opcionales 64</p> <p>W2. Piezas opcionales (estirador de sisa) 68</p> <p>W3. Piezas opcionales (eyector de aire) 68</p> <p>W4. Piezas opcionales (Juego de alimentación inferior) 68</p> <p>X. Piezas opcionales (Pedal de soporte) 70</p> <p>Z1. Accesorios (que vienen con la máquina de coser automática) 70</p> <p>Z2. Accesorios (con el cuerpo de la máquina) 72</p> <p>INDICE 73</p> <p>Piezas opcionales (Luz de marcación) 85</p> <p>LISTA DE PIEZAS CALIBRADORAS 86</p>
--	--

A. 主体関係/Machine body/Maschinengehäuse/
Corps de la machine/Cuerpo de la máquina

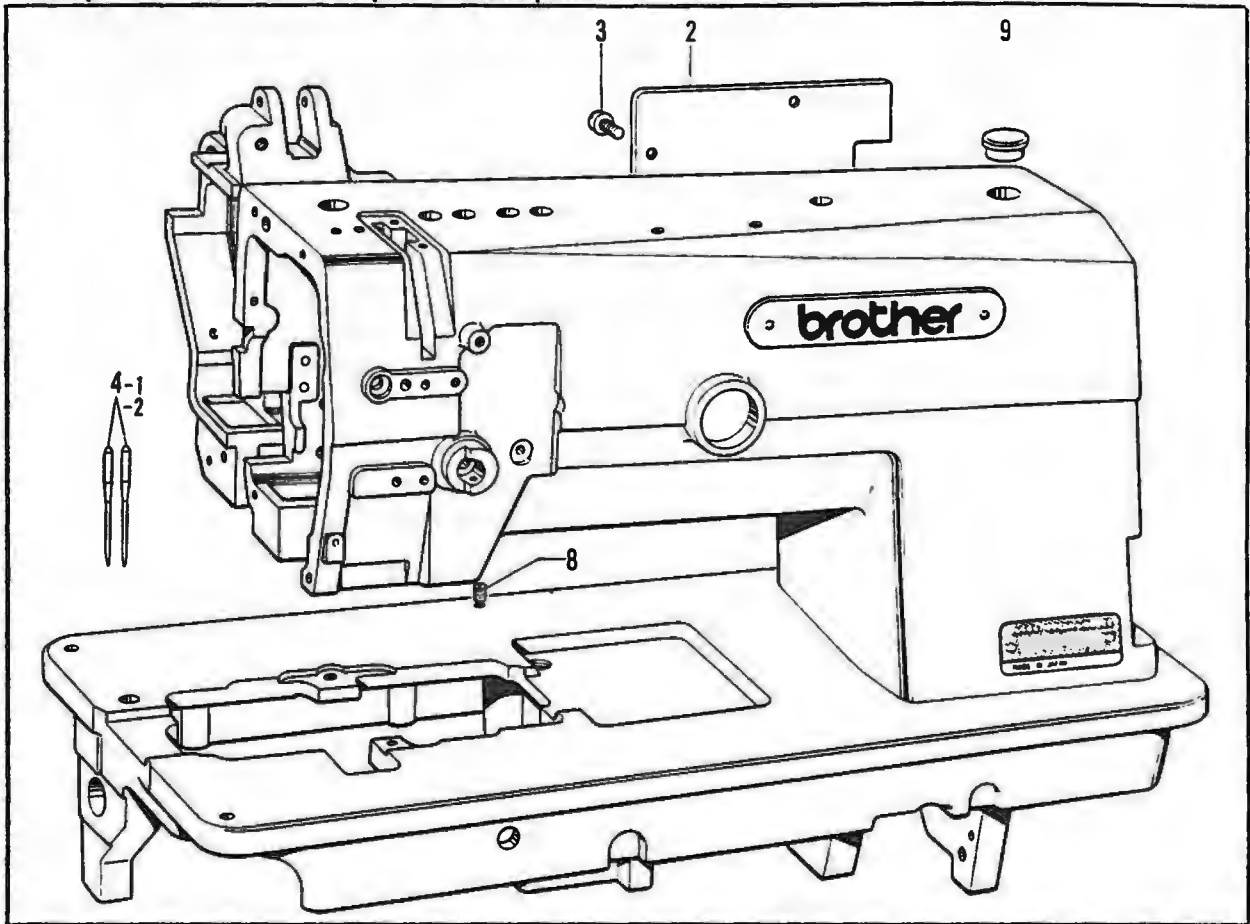

B. 上軸関係/Upper shaft mechanism/Obere welle/
Mécanisme de l'arbre supérieur/Mecanismo de la eje superior

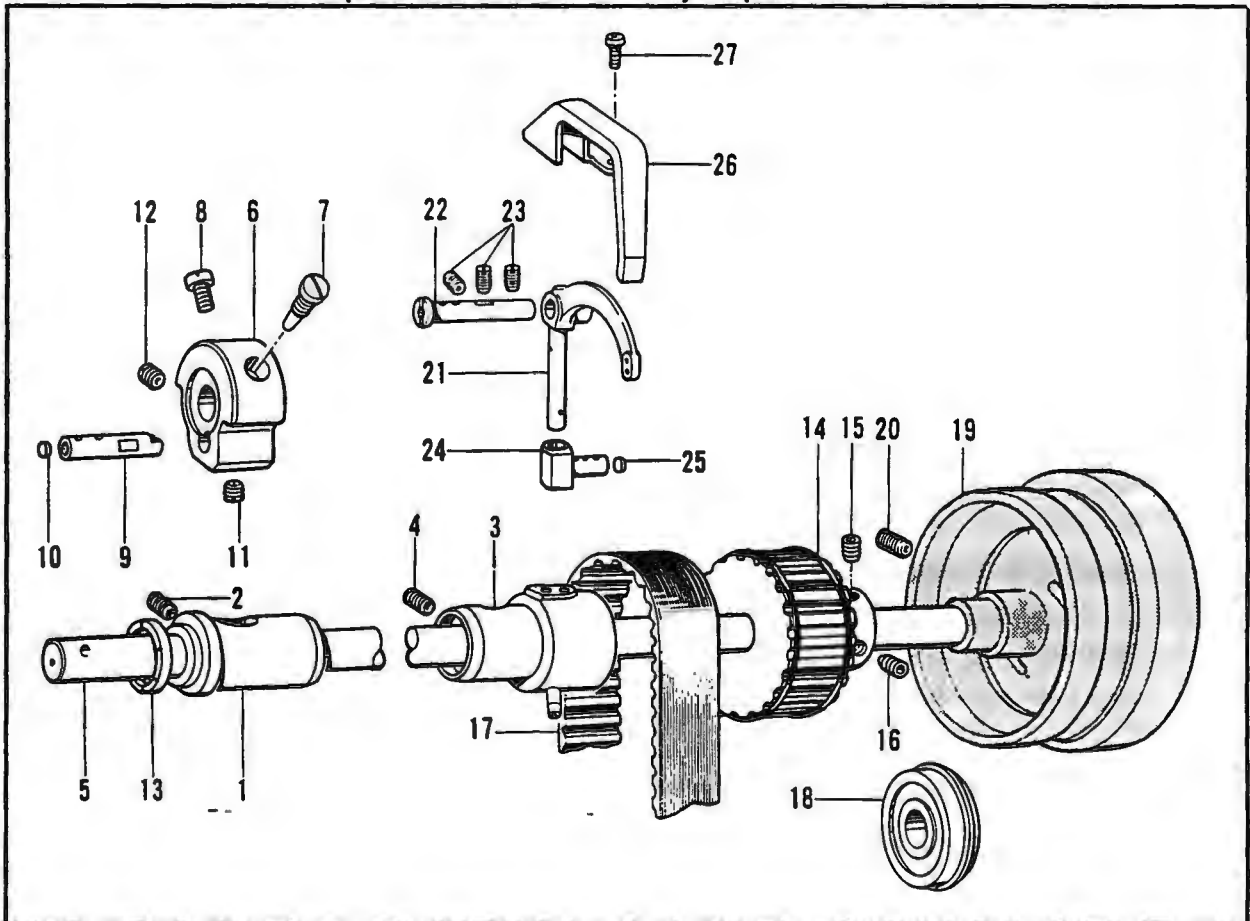

A. 主体関係/Machine body/Maschinengehäuse/
Corps de la machine/Cuerpo de la máquina

REF NO	CODE	QTY	品名	NAME OF PARTS	RMKS
2	S14640009	1	カフイタ	REAR COVER	
3	062680812	6	ナヘコ37-40X8	SCREW 437X8	
4-1	153011016	2	ミシンハリMTX190 #16	NEEDLE MTX190 (#16)	
8	013719412	2	トメネシ4.76クホミ	SET SCREW 4.76	
9	159150009	1	カマシクメクラセン	OIL CAP	
<オプション/OPTION >					
4-2	153011018	2	ミシンハリMTX190 #18	NEEDLE MTX190 (#18)	

B. 上軸関係/Upper shaft mechanism/Obere welle/
Mécanisme de l'arbre supérieur/Mecanismo de la eje superior

REF.NO.	CODE	QTY	品名	NAME OF PARTS	RMKS
1	112573101	1	ウツシクメタルL	UPPER SHAFT BUSH (L)	
2	013781012	1	トメネシ6.35クホミ	SET SCREW 6.35	
3	S07330101	1	ウツシクメタルMクミ	UPPER SHAFT BUSH (M) ASSEMBLY	
4	013780710	1	トメネシ6.35クホミ	SET SCREW 6.35	
5	S14668001	1	ウツシク	UPPER SHAFT	
6	112574000	1	デンビソクランク	THREAD TAKE-UP CRANK	
7	100250001	1	シメネシ7.14	SCREW 7.14	
8	146141001	1	アタマツキトメネシ7.14	SET SCREW 7.14	
9	112577101	1	ハリボソクランク	NEEDLE BAR CRANK	
10	113014000	1	クミヒモフタ	PUSHER	
11	101706001	1	トメネシ6.35	SET SCREW 6.35	
12	100251001	1	トメネシ6.35	SET SCREW 6.35	
13	112576001	1	デンビソクランクリンク	THREAD TAKE-UP CRANK RING	
14	180157001	1	タイミングプーリウクミ	TIMING PULLEY (U) ASSEMBLY	
15	014771022	1	アタメネシ6.35クホミ	SET SCREW 6.35	
16	016771032	1	アタメガリ635X10	SET SCREW 635X10	
17	112586001	1	タイミングベルト	TIMING BELT	
18	158115001	1	タマシクウケ6204ZZNR	BALL BEARING 6204ZZNR	
19	S07340009	1	プーリ	PULLEY	
20	S09670001	2	トメクホミ595-28X14	SET SCREW 595X14	
21	S09252001	1	デンビソク	THREAD TAKE-UP	
22	S07334001	1	デンビソク	THREAD TAKE-UP SHAFT	
23	013781012	3	トメネシ6.35クホミ	SET SCREW 6.35	
24	S07338001	1	デンビソクスベリコ	THREAD TAKE-UP SLIDE BLOCK	
25	113024000	1	クミヒモフタ	PUSHER	
26	S07339009	1	デンビソクカバー	THREAD TAKE-UP COVER	
27	062670512	2	ナヘコ357-40X5	SCREW 357X5	

C. 針棒搖動關係/Needle bar rocking mechanism/Nadelstangenbetätigung/
 Mécanisme de balancement de la barre à aiguille/Mecanismo de oscilación de la barra de aguja

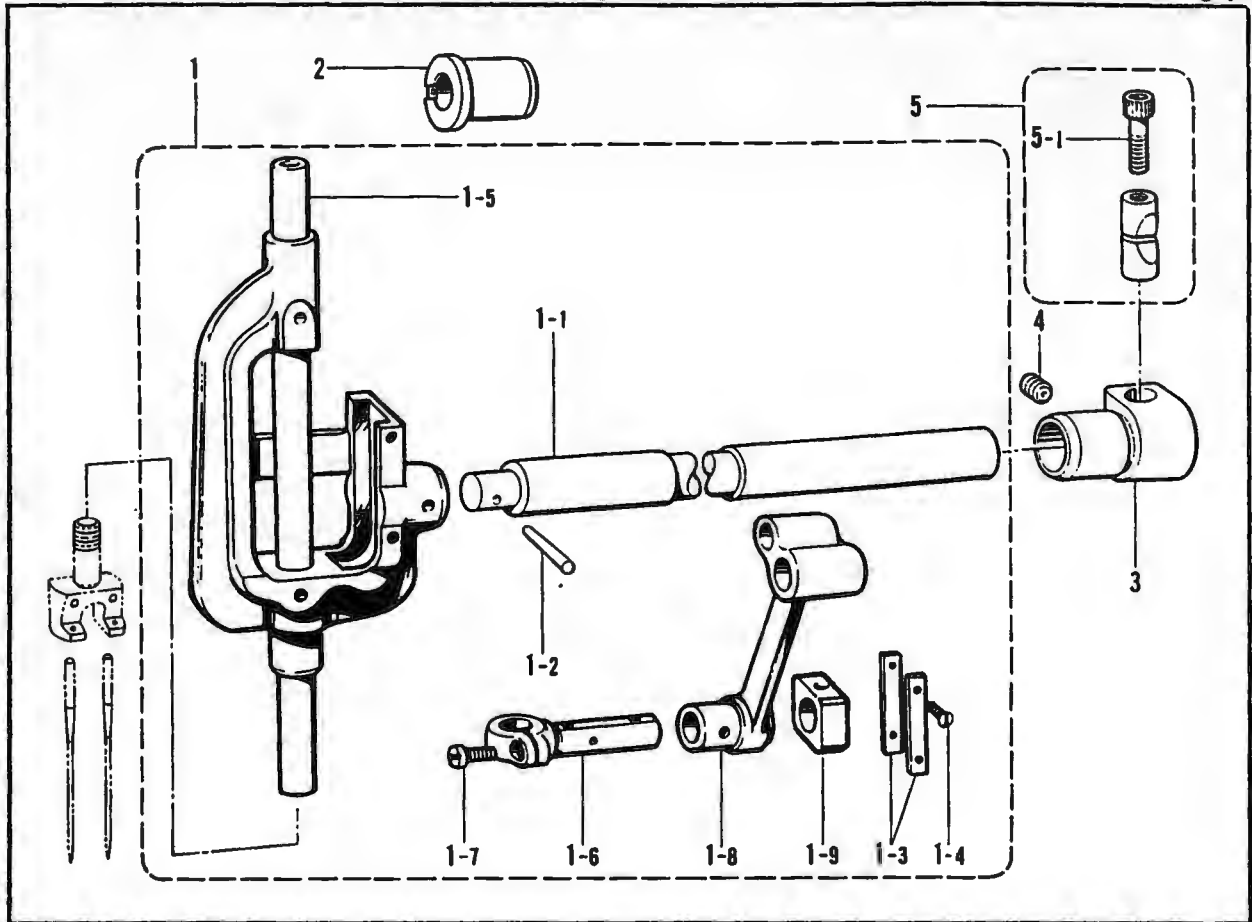

D. 下軸關係/Lower shaft mechanism/Untere welle/
 Mécanisme de l'arbre inférieur/Mecanismo del eje inferior

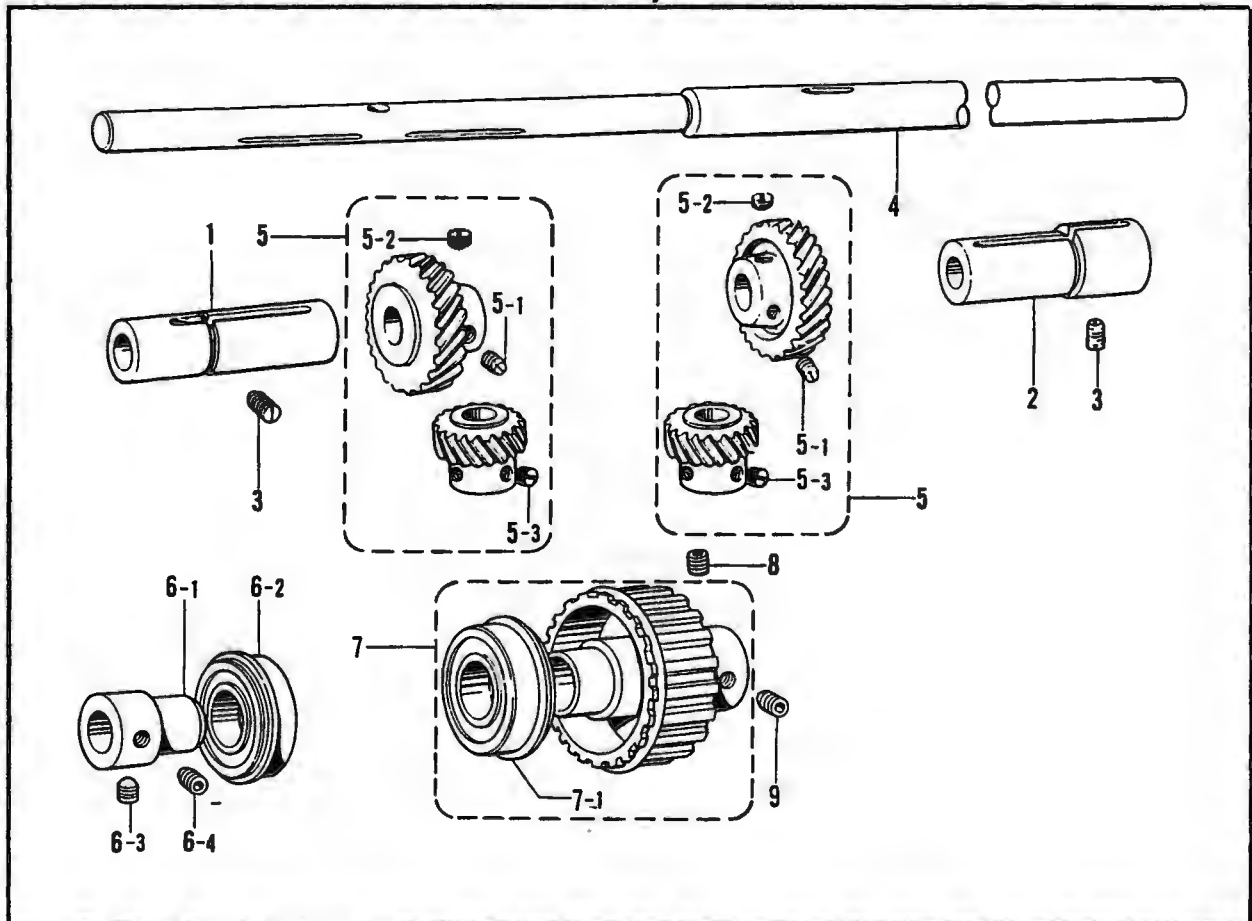

C. 針棒揺動関係/Needle bar rocking mechanism/Nadelstangenbetätigung/
 Mécanisme de balancement de la barre à aiguille/Mecanismo de oscilación de la barra de aguja

REF NO.	CODE	Q'TY	ヒンメイ	NAME OF PARTS	RMKS
	S15580001	1	ハリホ"ウヨウト"ウシ"クミ	NEEDLE BAR ROCK SHAFT ASSEMBLY	
1-1	112588101	1	ハリホ"ウヨウト"ウシ"ク	NEEDLE BAR ROCK SHAFT	
1-2	107030001	1	テーパ"ピン	TAPER PIN	
1-3	112590001	2	ハリホ"ウアンナイイタ	GUIDE PLATE	
1-4	102731004	4	サラネジ"2.38	SCREW 2.38	
1-5	153009001	1	ハリホ"ウ	NEEDLE BAR	
1-6	112592001	1	ハリホ"ウタ"キ	NEEDLE BAR CLAMP	
1-7	062670812	1	ナヘ"コ357-40X8	SCREW 357X8	
1-8	112593001	1	ハリホ"ウクランク"ロツト"	NEEDLE BAR CRANK ROD	
1-9	112721001	1	ハリホ"ウレンカン"カクコマ	SLIDE BLOCK	
2	112594001	1	ヨウト"ウシ"ク"メタルL	NEEDLE BAR ROCK SHAFT BUSH (L)	
3	153012101	1	ヨウト"ウシ"ク"ストツパ"	STOPPER	
4	013780710	1	トメネジ"6.35クホ"ミ	SET SCREW 6.35	
5	S09132001	1	ピンチスリーブ"クミ	PINCH SLEEVE ASSEMBLY	
5-1	018063022	1	アナホ"ルト6X30	BOLT 6X30	

D. 下軸関係/Lower shaft mechanism/Untere welle/
 Mécanisme de l'arbre inférieur/Mecanismo del eje inferior

REF NO.	CODE	Q'TY	ヒンメイ	NAME OF PARTS	RMKS
1	S09287000	1	カマト"タイ"メタルL	ROTARY HOOK BASE BUSH (L)	
2	S09288000	1	カマト"タイ"メタルR	ROTARY HOOK BASE BUSH (R)	
3	013781012	2	トメネジ"6.35クホ"ミ	SET SCREW 6.35	
4	S07439001	1	シタシ"ク	LOWER SHAFT	
5	S12445001	2	スハ"イ"ラルキ"ヤクミA	SPIRAL GEAR ASSEMBLY (A)	
5-1	112684001	2	トメネジ"6.35	SET SCREW 6.35	
5-2	100251001	4	トメネジ"6.35	SET SCREW 6.35	
5-3	131007001	6	トメネジ"6.35クホ"ミ	SET SCREW 6.35	
6	S07446001	1	タマシ"クウケク"ミ	BALL BEARING ASSEMBLY	
6-1	S07447001	1	タマシ"クウケフ"ツシユ	BALL BEARING BUSH	
6-2	072600480	1	タマシ"クウケ6004ZZNR	BALL BEARING 6004ZZNR	
6-3	148821001	1	アナトメネジ"6.35トガ"リ	SET SCREW 6.35	
6-4	014771022	1	アナトメネジ"6.35クホ"ミ	SET SCREW 6.35	
7	S07442001	1	タイミンク"プ"ーリDクミ	TIMING PULLEY (D) ASSEMBLY	
7-1	158115001	1	タマシ"クウケ6204ZZNR	BALL BEARING 6204ZZNR	
8	014771022	1	アナトメネジ"6.35クホ"ミ	SET SCREW 6.35	
9	148821001	1	アナトメネジ"6.35トガ"リ	SET SCREW 6.35	

E. メス関係/Knife mechanism/Messer/
Mécanisme du couteau/Mecanismo del cuchilla

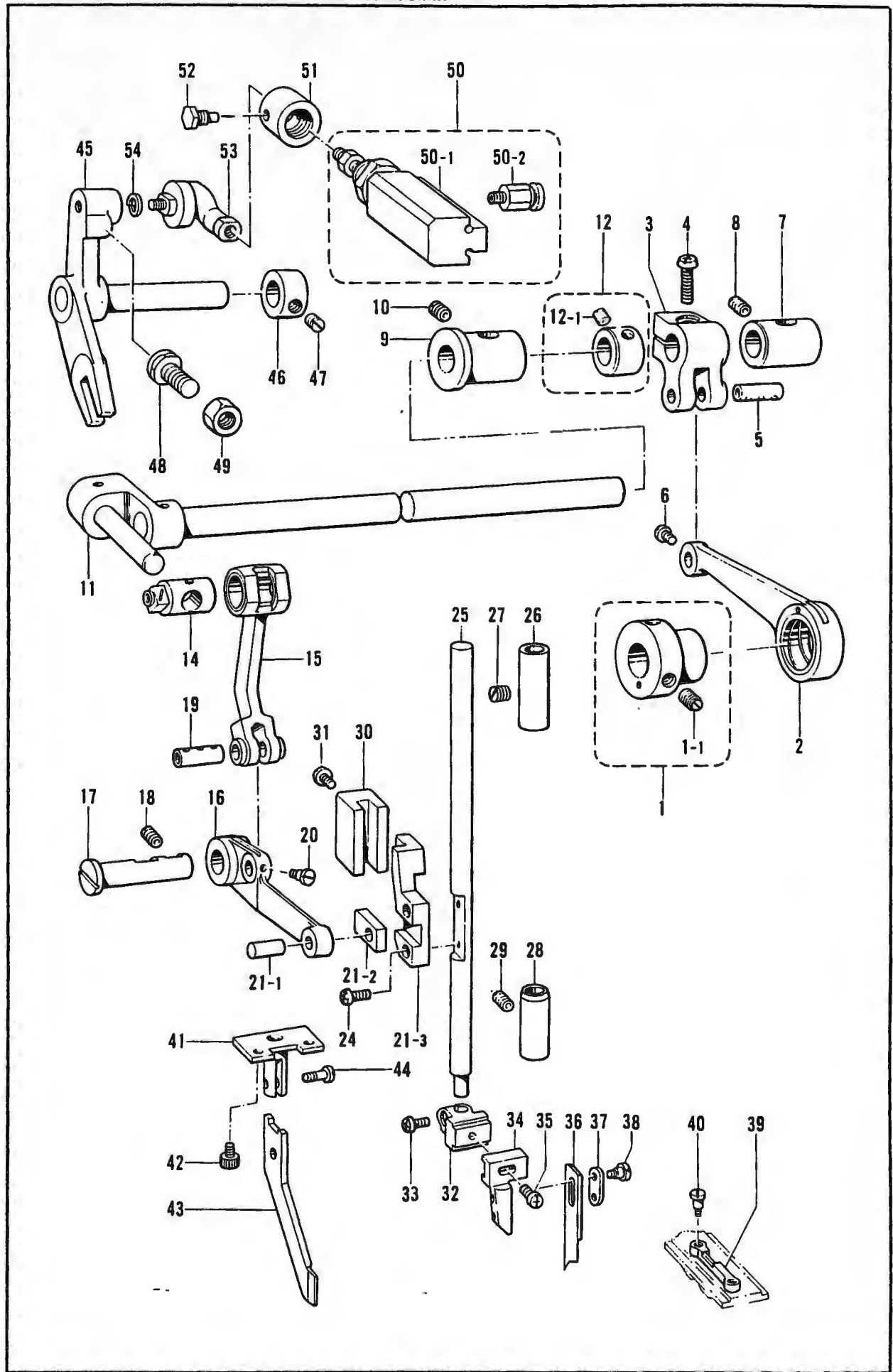

E. メス関係/Knife mechanism/Messer/
Mécanisme du couteau/Mecanismo del cuchilla

REF NO	CODE	Q'TY	ヒンメイ	NAME OF PARTS	RMKS
1	153015001	1	クトウヘンシンリンネジツキ	ECCENTRIC WHEEL WITH SCREW	
1-1	151604001	2	トメネジ5.95	SET SCREW 5.95	
2	S14642001	1	クトウシクレンカン	CRANK SHAFT CONNECTING ROD	
3	S14674001	1	クトウシクウテ	CRANK SHAFT ARM	
4	062751612	1	ナヘゴ556-32X16	SCREW 556X16	
5	143625001	1	シク6.35X17	STUD 6.35X17	
6	110563001	1	シメネジ3.18	SCREW 3.18	
7	143626000	1	クトウシクメタルR	UPPER KNIFE ROCK SHAFT BUSH (R)	
8	013781012	1	トメネジ6.35クホミ	SET SCREW 6.35	
9	143627000	1	クトウシクメタルL	UPPER KNIFE ROCK SHAFT BUSH (L)	
10	013781012	1	トメネジ6.35クホミ	SET SCREW 6.35	
11	S14643001	1	ヨウトウウテクミ	ROCK ARM ASSEMBLY	
12	183677001	1	セツトカラネジツキ	SET COLLAR WITH SCREW	
12-1	100260001	2	トメネジ5.95	SET SCREW 5.95	
14	S14647001	1	サトウレンカンスヘリコクミ	DRIVING ROD SLIDE BLOCK ASSEMBLY	
15	S14649001	1	サトウレンカン	DRIVING ROD	
16	S14650001	1	サトウレハ-	DRIVING LEVER	
17	S14651001	1	サトウレハ-シク	DRIVING LEVER SHAFT	
18	013781012	1	トメネジ6.35クホミ	SET SCREW 6.35	
19	143625001	1	シク6.35X17	STUD 6.35X17	
20	110563001	1	シメネジ3.18	SCREW 3.18	
21	183699001	1	メスホウアンナイクミ	KNIFE BAR GUIDE ASSEMBLY	
21-1	143637001	1	シク5.5X11	STUD 5.5X11	
21-2	143646000	1	メスホウアンナイカクコマ	KNIFE BAR GUIDE BLOCK	
21-3	S14652001	1	メスホウアンナイ	KNIFE BAR GUIDE	
24	062670812	2	ナヘゴ357-40X8	SCREW 357X8	
25	S14653001	1	メスホウ	KNIFE BAR	
26	S14654001	1	メスホウメタルU	KNIFE BAR BUSH (U)	
27	013781012	1	トメネジ6.35クホミ	SET SCREW 6.35	
28	S14655001	1	メスホウメタルD	KNIFE BAR BUSH (D)	
29	013781012	1	トメネジ6.35クホミ	SET SCREW 6.35	
30	S14656001	1	メスシクアンナイ	KNIFE SHAFT GUIDE	
31	062671012	2	ナヘゴ357-40X10	SCREW 357X10	
32	S14657001	1	メスホルダ-	KNIFE HOLDER	
33	062670712	1	ナヘゴ357-40X7	SCREW 357X7	
34	S14658001	1	メストリツクホウ	KNIFE SET BAR	
35	112751003	1	シメネジ3.57	SCREW 3.57	
36	S16248001	1	ウフメスB	UPPER KNIFE (B)	
37	143641001	1	メスオサエイタ	UPPER KNIFE PRESSER PLATE	
38	143642101	2	メスオサエイタ"ンネジ"	KNIFE PRESSER STUD SCREW	
39	153020001	1	コテイハ	FIXED KNIFE	
40	148539101	2	ダ"ンネジ"2.38	STUD SCREW 2.38	
41	S14659001	1	メスカイト"ホウ	KNIFE GUIDE SHAFT	
42	S00208001	2	アナホルト3.57X7	BOLT 3.57X7	
43	S14660001	1	ナカメスカイト"	INNER KNIFE GUIDE	
44	113050001	1	シメネジ3.57	SCREW 3.57	
45	S14661009	1	キリカエレハ"クミ	SELECTOR LEVER ASSEMBLY	
46	146581001	1	セツトカラ-	SET COLLAR	
47	100260001	2	トメネジ5.95	SET SCREW 5.95	
48	115585001	1	ホルト7.94	BOLT 7.94	
49	152997001	1	ナツト7.94	NUT 7.94	
50	S14665000	1	シリンダ"クミ	CYLINDER ASSEMBLY	
50-1	S14666000	1	シリンダ"15X20	CYLINDER 15X20	
50-2	S04905000	2	ハーフユニオン	HALF UNION	
51	S14667001	1	シリンダ"ダイ	CYLINDER BASE	
52	140620001	2	シリンダ"ササエネジ"	CYLINDER SUPPORT SCREW	
53	S08408000	1	リンクボール	LINK BALL	
54	028050243	1	ハ"ネサ"カ"ネ2-5	SPRING WASHER 2-5	

F. カマ関係/Rotary hook mechanism/Greifervorrichtung/
Mécánisme du crocher rotatif/Mecanismo del cangrejo

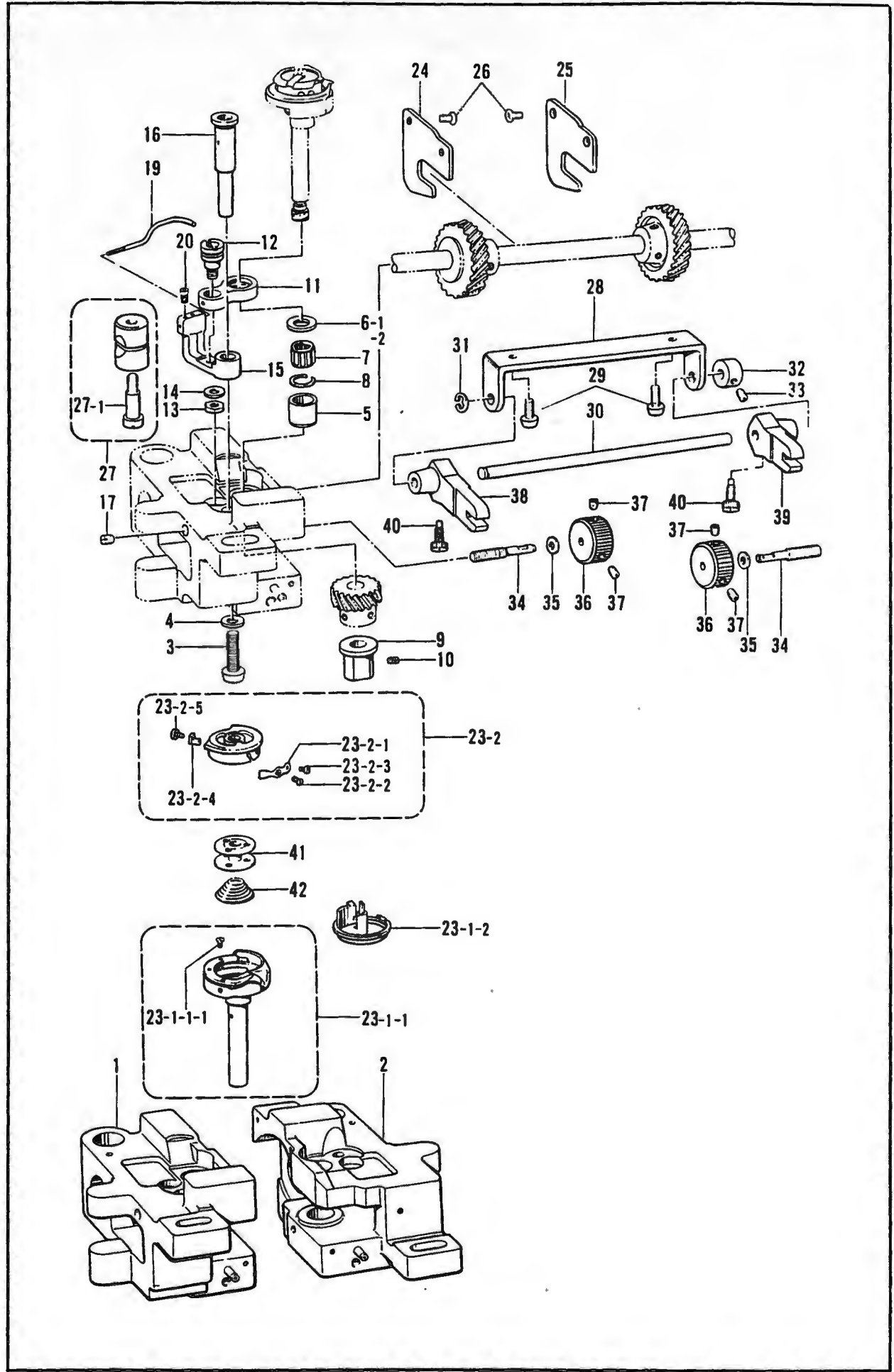

F. カマ関係 / Rotary hook mechanism / Greifervorrichtung /
Mécanisme du crocher rotatif / Mecanismo del cangrejo

REF NO.	CODE	Q'TY	品名	NAME OF PARTS	RMKS
	S09255201	1	カマト"ク"イL	ROTARY HOOK BASE (L)	
	S15068101	1	カマト"ク"イR	ROTARY HOOK BASE (R)	
3	062782512	2	ナヘ"コ635-28X25	SCREW 635X25	
4	100197002	2	ワ"カ"ネ	WASHER	
5	S09255001	2	カマシ"ク"メタルU	ROTARY HOOK SHAFT BUSH (U)	
6-1	S09260001	2	スラストリング"A(1.2MM)	THRUST RING (A) (1.2MM)	
6-2	S09261001	2	スラストリング"B(1.4MM)	THRUST RING (B) (1.4MM)	
7	S07420000	2	ニードル"ル"ヘアリング"	NEEDLE BEARING	
8	S07419001	2	ストップ"リング"	STOP RING	
9	S07417001	2	カマシ"ク"メタルD	ROTARY HOOK SHAFT BUSH (D)	
10	013710512	2	トメネジ"4.76ク"ホ"ミ	SET SCREW 4.76	
11	150967101	2	オープナー"リンク"	OPENER LINK	
12	148005001	2	オープナー"リンク"シ"ク"	OPENER LINK SHAFT	
13	110161006	2	ナツ"4.76	NUT 4.76	
14	025710232	2	ヒロサ"カ"ネチユウ4.76	PLAIN WASHER 4.76	
15	S09262101	2	オープナー"レバー"	OPENER LEVER	
16	S13021001	2	オープナー"レバー"シ"ク"	OPENER LEVER SHAFT	
17	013711012	2	トメネジ"4.76ク"ホ"ミ	SET SCREW 4.76	
19	S07423101	2	オープナー	OPENER	
20	S07424001	4	トメネジ"3.18	SET SCREW 3.18	
23	S09264001	2	ニホンハリカマ	TWIN NEEDLE ROTARY HOOK ASSEMBLY	
23-1	S13615001	2	カマクミ	ROTARY HOOK ASSEMBLY	
23-1-1	S09268001	2	ソトカマクミ	OUTER ROTARY HOOK ASSEMBLY	
23-1-1-1	151027001	4	ウチカマオウセトメネジ"	INNER ROTARY HOOK SET SCREW	
23-1-2	S09273001	2	ウチカマクミ	INNER ROTARY HOOK ASSEMBLY	
23-2	S09278001	2	キャップ"クミ"	CAP ASSEMBLY	
23-2-1	156521001	2	チヨウシハ"ネ"	TENSION SPRING	
23-2-2	151029001	2	チヨウシネジ"	TENSION ADJUST SCREW	
23-2-3	151030001	2	チヨウシハ"ネ"トメネジ"	SET SCREW	
23-2-4	S09284001	2	シタイトホシ"イタ"	LOWER THREAD HOLDING PLATE	
23-2-5	159802001	2	シメネジ"1.59X2	SCREW 1.59X2	
24	S07436001	1	キ"ヤアン"ナイL	GEAR GUIDE (L)	
25	S07437001	1	キ"ヤアン"ナイR	GEAR GUIDE (R)	
26	108960002	4	サラネジ"3 57	SCREW 3.57	
27	S07658001	2	ピンチスリーブ"クミ"	PINCH SLEEVE ASSEMBLY	
27-1	112700001	2	シメネジ"5.95	SCREW 5.95	
28	S07430001	1	ハリスキチヨウセツホ"ウササエ	ADJUST BAR SUPPORT	
29	062711012	2	ナヘ"コ476-32X10	SCREW 476X10	
30	S07431001	1	ハリスキチヨウセツホ"ウ"	ADJUST BAR	
31	048040342	1	トメフE4	STOP RING E4	
32	159436001	1	セツ"カラ"	SET COLLAR	
33	014680622	1	アナトメネジ"4.37ク"ホ"ミ	SET SCREW 4.37	
34	S07434001	2	ハリスキチヨウセツネジ"	ADJUST SCREW	
35	025680132	2	ヒロサ"カ"ネシヨウ4.37	PLAIN WASHER 4.37	
36	S07435001	2	ハリスキチヨウセツナツ"ト"	ROTARY HOOK BASE ADJUST DIAL	
37	014680622	4	アナトメネジ"4.37ク"ホ"ミ	SET SCREW 4.37	
38	S07432001	1	ハリスキチヨウセツフタマタL	ADJUST FORKED LEVER (L)	
39	S07433001	1	ハリスキチヨウセツフタマタR	ADJUST FORKED LEVER (R)	
40	131226001	2	ハリトメネジ"3.57	NEEDLE SET SCREW 3.57	
41	S09285001	2	ホ"ビ"ン	BOBBIN	
42	156557001	2	クウテンホ"ウシハ"ネ"	BOBBIN TENSION SPRING	

G. 給油潤滑關係 / Lubrication / Schmierung /
Lubrification / Lubricación

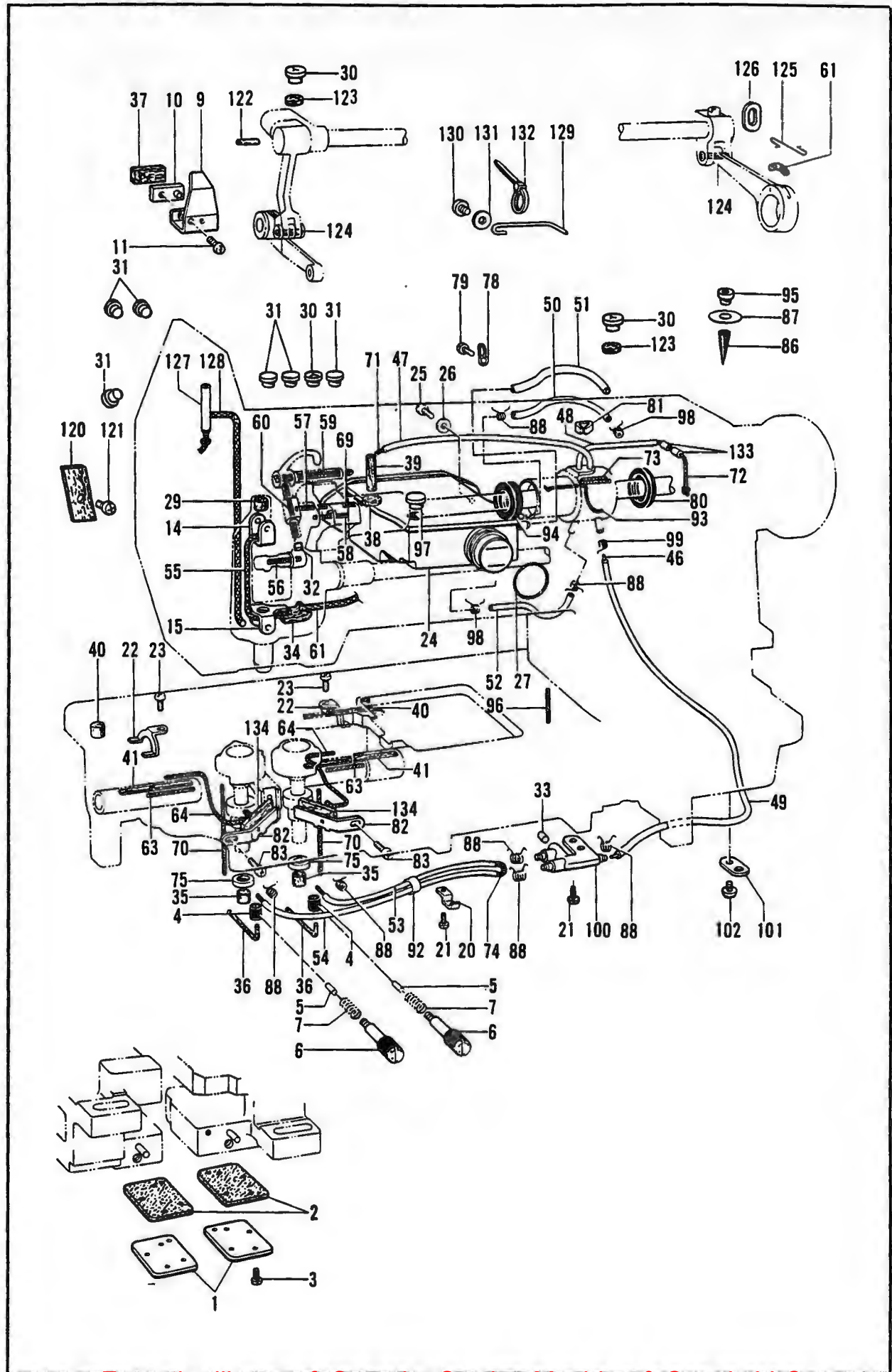

G. 給油潤滑関係 / Lubrication / Schmierung /
Lubrification / Lubricación

REF.NO.	CODE	Q'TY	ヒンメイ	NAME OF PARTS	RMKS
1	S07448001	2	カマト"タ"イフタ	ROTARY HOOK BASE COVER	
2	S07449000	2	カマト"タ"イハ"ツキン	ROTARY HOOK BASE PACKING	
3	062670812	8	ナヘ"コ357-40X8	SCREW 357X8	
4	S07477000	2	ゴムリング"	RUBBER RING	
5	S07478000	2	ゴムオサエ	RUBBER PRESSER	
6	S07479101	2	オイルチヨウセツネジ"	ADJUST SCREW	
7	S16114001	2	オイルチヨウセツハ"ネ	SPRING	
9	150988001	1	オイルヨクイタ	OIL STOPPER PLATE	
10	112717001	1	オイルヨクイタオサエカネ	OIL STOPPER PLATE PRESSER	
11	062711212	1	ナヘ"コ476-32X12	SCREW 476X12	
14	112719001	1	フェルトオサエU	FELT SUPPORT (U)	
15	112720101	1	フェルトオサエD	FELT SUPPORT (D)	
20	142268001	1	コード"オサエL	CORD HOLDER (L)	
21	062670512	3	ナヘ"コ357-40X5	SCREW 357X5	
22	S07471001	2	ヒモササエ	WICK HOLDER	
23	062670512	2	ナヘ"コ357-40X5	SCREW 357X5	
24	S07450109	1	オイルタンククミ	OIL TANK ASSEMBLY	
25	062711012	2	ナヘ"コ476-32X10	SCREW 476X10	
26	025710232	2	ヒラサ"カ"ネチユウ4.76	PLAIN WASHER 4.76	
27	081030070	1	Oリング" P30	O RING P30	
29	148394000	1	ハリボ"ウセン	NEEDLE BAR CAP	
30	140890009	3	オイルカツプ	OIL CAP	
31	104821009	6	メクラセン	OIL CAP	
32	142274009	1	メクラセン	OIL CAP	
33	142274009	1	メクラセン	OIL CAP	
34	S07474000	1	フェルト	FELT	
35	151927001	2	クラツチフェルト	CLUTCH FELT	
36	S07476000	2	フェルト	FELT	
37	148762001	1	デンヒ"ンフェルト	FELT	
38	112734001	1	ウツジ"クメタルLフェルト	UPPER SHAFT BUSH (L) FELT	
39	S07571000	1	フェルト	FELT	
40	112753001	2	フェルト	FELT	
41	113362001	2	カマト"タ"イメタルRフェルト	ROTARY HOOK BASE BUSH (R) FELT	
46	S07460100	1	ワイヤ-	WIRE	
47	S07453000	1	ヒ"ニールチューブ"	OIL TUBE	
48	143669000	1	ヒ"ニールチューブ"	OIL TUBE	
49	S07455100	1	ヒ"ニールチューブ"	OIL TUBE	
50	S07456000	1	ヒ"ニールチューブ"	OIL TUBE	
51	S07457100	1	ヒ"ニールチューブ"	OIL TUBE	
52	S07810000	1	ヒ"ニールチューブ"	OIL TUBE	
53	S07458100	1	ヒ"ニールチューブ"	OIL TUBE	
54	S07459100	1	ヒ"ニールチューブ"	OIL TUBE	
55	S07465000	1	クミヒモ (L=200)	WICK (L=200)	
56	112728001	1	クミヒモ (L=50)	WICK (L=50)	
57	114693001	1	クミヒモ (L=30)	WICK (L=30)	
58	112735000	1	クミヒモ (L=45)	WICK (L=45)	
59	113653000	1	クミヒモ (L=130)	WICK (L=130)	
60	S03289001	1	クミヒモ4X4 (L=40)	WICK 4X4 (L=40)	
61	112293001	1	ハリボ"ウリンクシ"クフェルト	FELT	
63	S07461000	2	クミヒモ (L=32)	WICK (L=32)	
64	108802001	2	クミヒモ4X4 (L=250)	WICK 4X4 (L=250)	
69	S07462000	1	クミヒモ (L=25)	WICK (L=25)	
70	S07463000	2	クミヒモ (L=70)	WICK (L=70)	
71	153920001	1	クミヒモ4X4 (L=300)	WICK 4X4 (L=300)	
72	S10167000	1	クミヒモ4X4 (L=200)	WICK 4X4 (L=200)	
73	S03289001	1	クミヒモ4X4 (L=40)	WICK 4X4 (L=40)	
74	S07464100	1	クミヒモ (L=530)	WICK (L=530)	
75	156070002	2	スヘ"ーサー	SPACER	
78	S07467001	1	チューブ"ササエ	TUBE HOLDER	
79	062680812	1	ナヘ"コ437-40X8	SCREW 437X8	
80	S07468000	1	オイルシール	OIL SEAL	
81	S07469001	1	チューブ"カシメ	TUBE CALKING	

G. 給油潤滑関係 / Lubrication / Schmierung /
 Lubrification / Lubricación

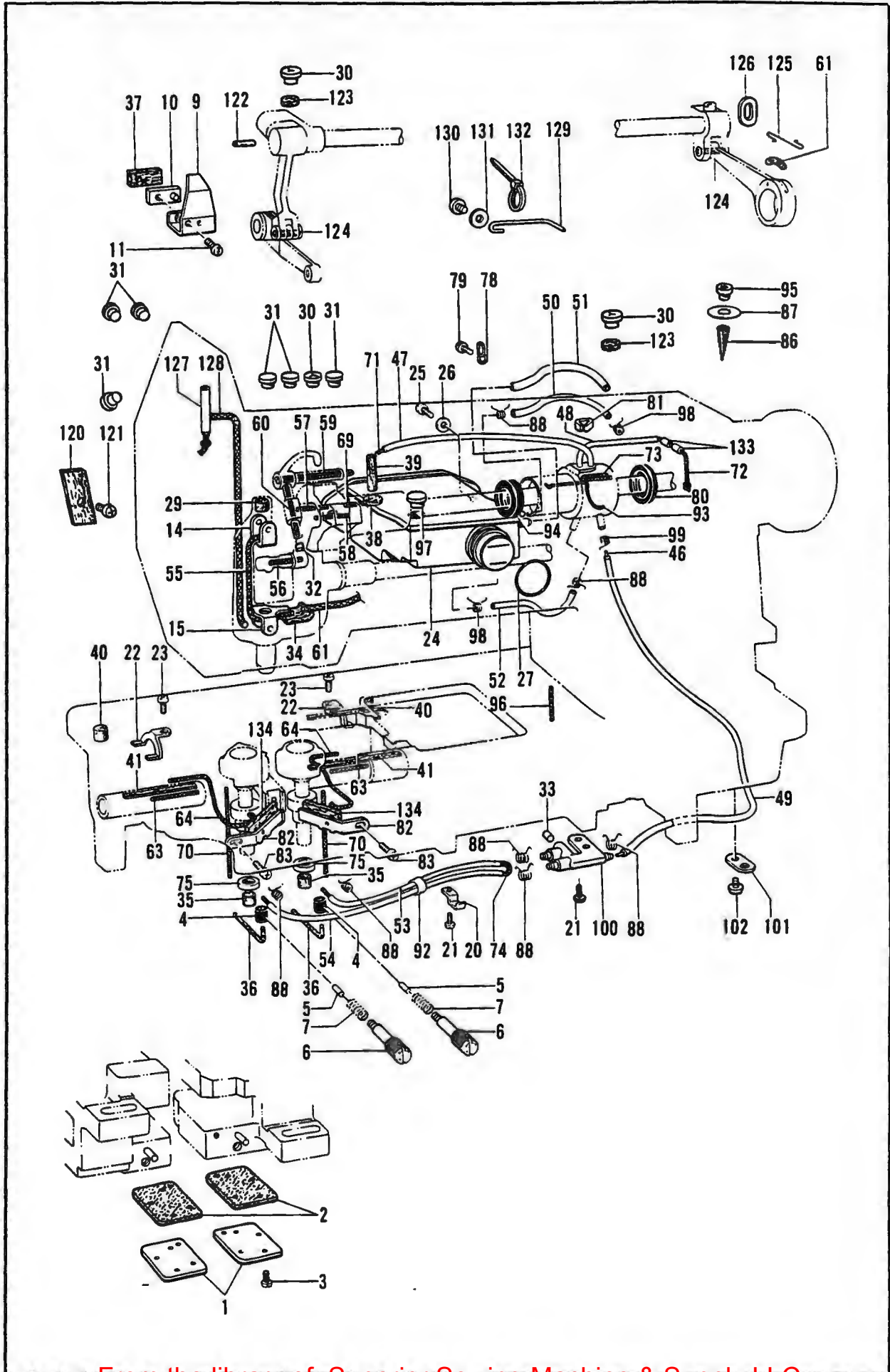

給油潤滑関係 / Lubrication / Schmierung /
Lubrication / Lubricación

REF.NO.	CODE	QTY	品名	NAME OF PARTS	RMKS
	S21195001	2	フェルトササイ	FELT HOLDER	
85	062670512	2	ナヘコ357-40X5	SCREW 357X5	
86	S07473000	1	オイルフィルター	OIL FILTER	
87	S07481009	1	オイルシート	OIL SEAT	
88	S07876001	7	チューブストツパー	TUBE CLAMP	
92	146253000	1	チューブ	OIL TUBE	
93	S09369000	1	クミヒモ (L=70)	WICK (L=70)	
94	S09364000	1	オイルシール	OIL SEAL	
95	112758009	1	ヘッドオイルフタ	OIL CAP	
96	111191001	1	クミヒモ (L=35)	WICK (L=35)	
97	104821009	1	メクラセン	OIL CAP	
98	S07876001	2	チューブストツパー	TUBE CLAMP	
99	S07876001	1	チューブストツパー	TUBE CLAMP	
100	S14189000	1	ターミナル	TERMINAL	
101	146536001	1	オクリホタンシクササイ	FEED ADJUST SHAFT SUPPORT	
102	062670512	1	ナヘコ357-40X5	SCREW 357X5	
120	143679000	1	フェルト	FELT	
121	060670612	1	ハイント357-40X6	SCREW 357X6	
122	153024000	1	クミヒモ (L=25)	WICK (L=25)	
123	143936000	2	フェルト	FELT	
124	112293001	2	ハリホウリンクシクフエルト	FELT	
125	116795000	1	クリツブ	CLIP	
126	143676000	1	レンガンオイルキリ	OIL SEAL	
127	S14685001	1	パイプ	PIPE	
128	152974001	1	クミヒモ4X4 (L=350)	WICK 4X4 (L=350)	
129	S18087001	1	チューブササイ	TUBE HOLDER	
130	062781412	1	ナヘコ635-28X14	SCREW 635X14	
131	151439002	1	サカネ	WASHER	
132	149799000	1	タイラツブS	BEAD BAND (S)	
133	S18385000	2	ビニールチューブ	OIL TUBE	
134	S21196001	2	フェルト	FELT	

H. 糸通シ関係 / Threading mechanism / Fadenführungsrichtung /
 Mécanisme de l'enfilage / Mecanismo de la enhebrado

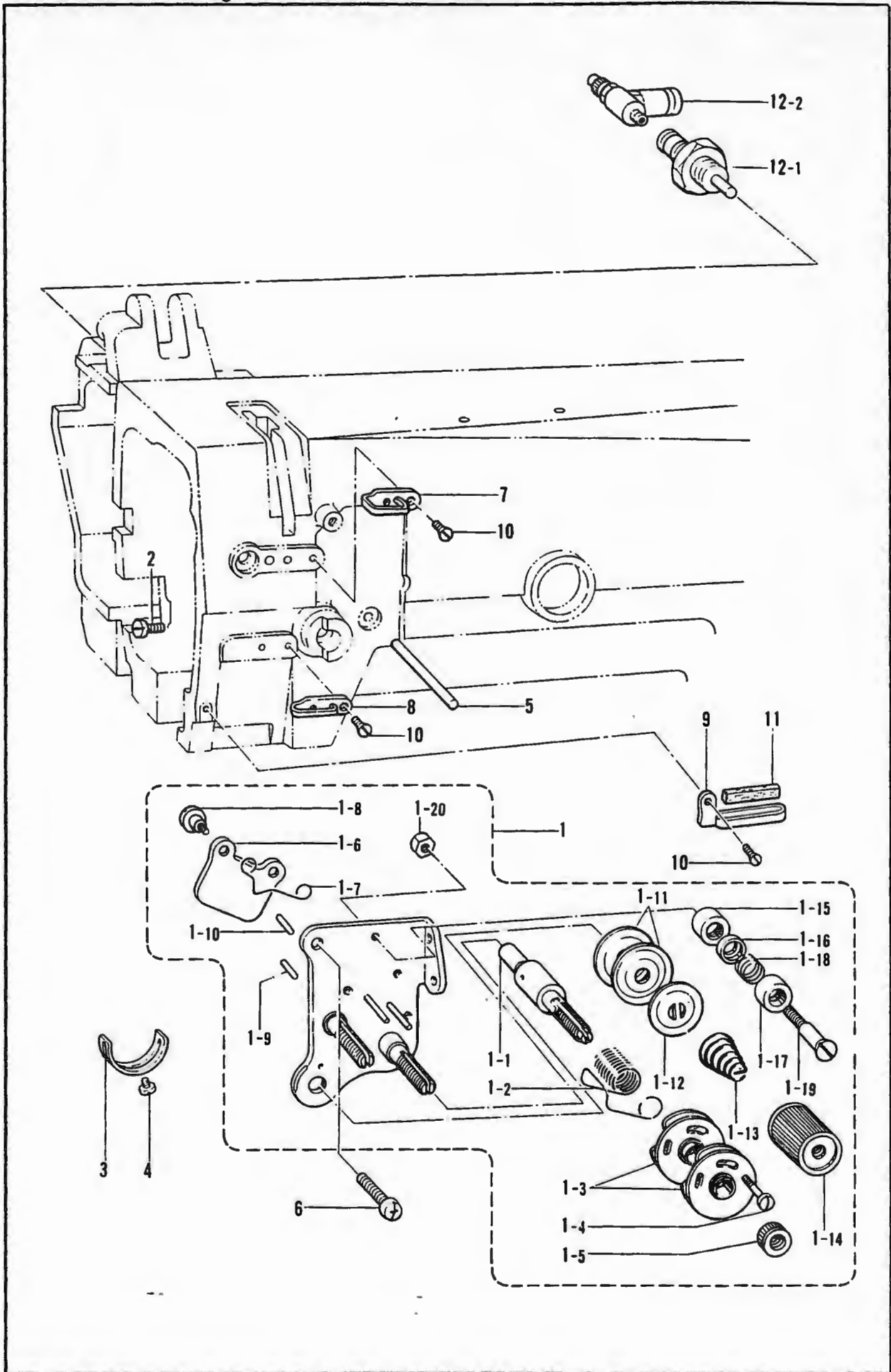

H. 糸通シ関係 / Threading mechanism / Fadenführungsrichtung /
Mécánisme de l'enfilage / Mecanismo de la enhebrado

REF NO	CODE	Q'TY	ヒンメイ	NAME OF PARTS	RMKS
1	S07489109	1	ウワイトチヨウシクミ	UPPER THREAD TENSION ASSEMBLY	
1-1	144680001	1	チヨウシク	TENSION STUD	
1-2	155491001	1	イトトリハ"ネ	SPRING	
1-3	108254001	2	イトトリハ"ネアンナイクミ	SPRING GUIDE ASSEMBLY	
1-4	144682001	1	シメネシ"2.38	SCREW 2.38	
1-5	108265009	1	イトチヨウシナツト	TENSION NUT	
1-6	S07487001	1	イトユルメイタ	TENSION RELEASE PLATE	
1-7	118320001	1	イトユルメハ"ネ	SPRING	
1-8	112712001	2	ダ"ンネシ"3.57	STUD SCREW 3.57	
1-9	158769001	1	イトユルメヒ"ンR	PIN (R)	
1-10	S07488001	1	イトユルメヒ"ンL	PIN (L)	
1-11	145446001	4	イトチヨウシサラ	TENSION DISC	
1-12	159805001	2	イトチヨウシサラオサエ	TENSION DISC PRESSER	
1-13	S07490001	2	イトチヨウシハ"ネ	TENSION SPRING	
1-14	149566009	2	イトチヨウシナツト	TENSION NUT	
1-15	144685001	2	イトアンナイフタ	THREAD GUIDE CAP	
1-16	144686001	2	イトアンナイサラ	THREAD GUIDE DISC	
1-17	144687001	2	イトアンナイダ"イ	THREAD GUIDE BRACKET	
1-18	144688001	2	イトアンナイハ"ネ	SPRING	
1-19	144689001	2	イトアンナイダ"ンネシ"	THREAD GUIDE STUD SCREW	
1-20	021670102	2	ナツト1シユ3.57	NUT 3.57	
2	100064002	1	シメネシ"3.57	SCREW 3.57	
3	112709001	1	イトトリハ"ネストツハ"	STOPPER	
4	062670512	1	ナヘ"コ357-40X5	SCREW 357X5	
5	S14677001	1	イトユルメシ"ク	TENSION RELEASE SHAFT	
6	062680812	1	ナヘ"コ437-40X8	SCREW 437X8	
7	108266001	1	ア-ムイトアンナイU	ARM THREAD GUIDE (U)	
8	112658001	1	ア-ムイトアンナイM	ARM THREAD GUIDE (M)	
9	112715001	1	ア-ムイトアンナイD	ARM THREAD GUIDE (D)	
10	108960002	3	サラネシ"3.57	SCREW 3.57	
11	114941001	1	ア-ムイトアンナイフエルト	FELT	
12	S15096000	1	シリンダ"クミ	CLINDER ASSEMBLY	
12-1	S15097000	1	シリンダ"10X5	CLINDER 10X5	
12-2	S15871000	1	スピコンツキ"デM5-4	SPEED CONTROLLER JOINT M5-4	

J. 糸切れ感知関係 / Thread breakage detector mechanism / Fadenbruchfühler /
Mécanisme du détecteur de cassure du fil / Mecanismo del sensor de cortes de hilo

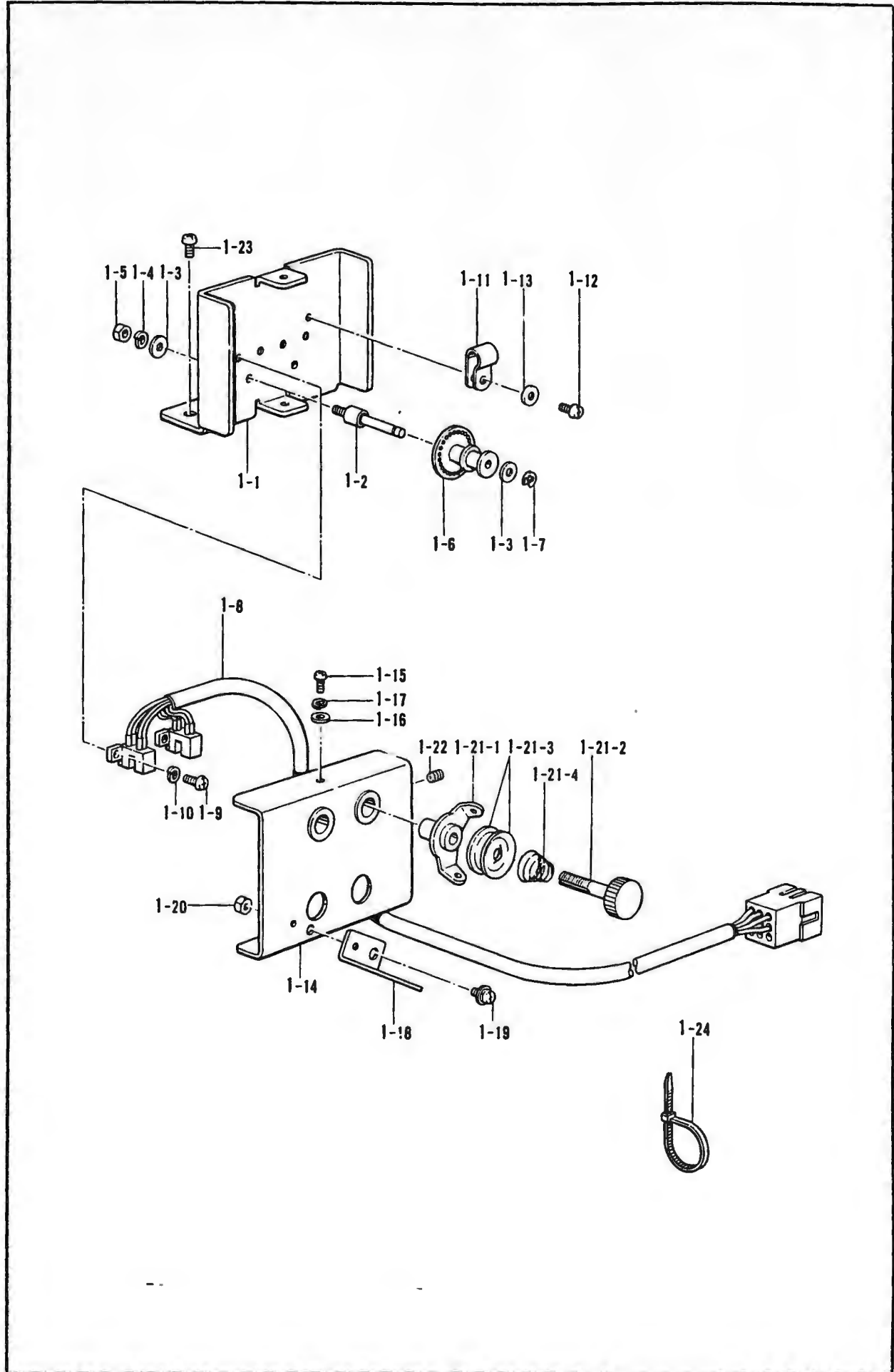

糸切れ感知関係/Thread breakage detector mechanism/Fadenbruchfühler/
 Mécanisme du détecteur de cassure du fil/Mecanismo del sensor de cortes de hilo

ITEM NO.	CODE	Q'TY	品名	NAME OF PARTS	RMKS
	S09399009	1	ウワイトキレカンチクミ	UPPER THREAD BREAKAGE SENSOR ASSEMBLY	
	S09400009	1	トリツケダテ	SET BRACKET	
	S09401001	2	シテンシク	FULCRUM SHAFT	
	025030233	4	ヒラサ"カ"ネチユウ3	PLAIN WASHER 3	
1-4	028030243	2	ハ"ネサ"カ"ネ2-3	SPRING WASHER 2-3	
1-5	021300103	2	ナツト1シユ3	NUT 3	
1-6	S09402101	2	プーリー	PULLEY	
1-7	048020342	2	トメフE2	STOP RING E2	
1-8	S08117000	1	イトキレセンサークミ	THREAD BREAKAGE SENSOR ASSEMBLY	
1-9	062300616	4	ナヘ"コM3X6	SCREW M3X6	
1-10	028030243	4	ハ"ネサ"カ"ネ2-3	SPRING WASHER 2-3	
1-11	S00480000	1	コードホルダ"5N	CORD HOLDER 5N	
1-12	062400616	1	ナヘ"コM4X6	SCREW M4X6	
1-13	025040233	1	ヒラサ"カ"ネチユウ4	PLAIN WASHER 4	
1-14	S09403009	1	カバー	COVER	
1-15	062300616	2	ナヘ"コM3X6	SCREW M3X6	
1-16	025030233	2	ヒラサ"カ"ネチユウ3	PLAIN WASHER 3	
1-17	028030243	2	ハ"ネサ"カ"ネ2-3	SPRING WASHER 2-3	
1-18	S03566001	1	メンタイトカケ	FACE PLATE THREAD GUIDE	
1-19	052400806	1	ナヘ"コハ"ネヒラ4X8	WASHER SCREW 4X8	
1-20	021400202	1	2シユナツト4	NUT 4	
1-21	183377001	2	プレテンションクミA	PRE-TENSION ASSEMBLY (A)	
1-21-1	S02611001	2	イトアンナイ	THREAD GUIDE	
1-21-2	S02612001	2	イトアンナイチヨウシホ"ウ	PRE-TENSION STUD	
1-21-3	144504001	4	イトアンナイサラ	THREAD GUIDE DISC	
1-21-4	154560001	2	プレテンションハ"ネA	PRE TENSION SPRING (A)	
1-22	014500522	2	アタメネシ"5クホ"ミ	SET SCREW 5	
1-23	062761212	2	ナヘ"コ595-28X12	SCREW 595X12	
1-24	S04557000	1	バンドイPLTIM	BAND PLTIM	

K. スタッカー関係/Stacker mechanism/Anhäufung/
Mécanisme de l'empileur/Mecanismo de apilador

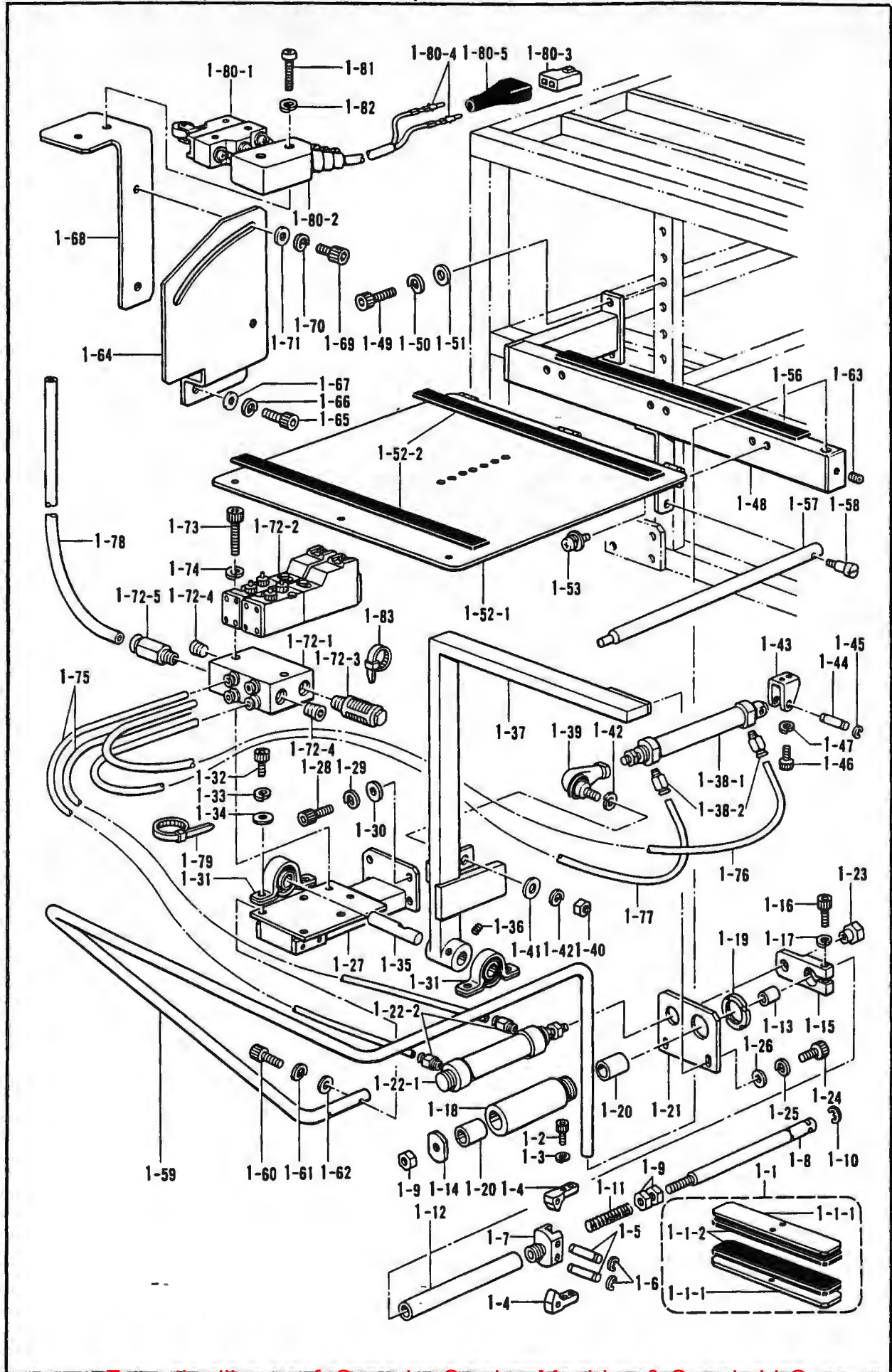

K. スタッカー関係/Stacker mechanism/Anhäufung/
Mécánisme de l'empileur/Mecanismo de apilador

REF.NO.	CODE	Q'TY	ヒンメイ	NAME OF PARTS	RMKS
1	S08431109	1	ツカミスタツカークミ	PICK-UP TYPE STACKER ASSEMBLY	
1-1	S08363001	2	チャツクアタマクミ	CHUCK HOLDER ASSEMBLY	
1-1-1	S08432001	2	チャツクアタマ	CHUCK HOLDER	
1-1-2	S08433000	2	チャツクゴム	CHUCK RUBBER	
1-2	018401022	4	アナホ"ルト4X10	BOLT 4X10	
1-3	028040242	4	ハ"ネサ"カ"ネ2-4	SPRING WASHER 2-4	
1-4	S08434001	2	チャツク	CHUCK	
1-5	S08435001	2	シテンシ"ク	FULCRUM SHAFT	
1-6	048030342	4	トメフE3	STOP RING E3	
1-7	S08436001	1	チャツクホルター	CHUCK HOLDER	
1-8	S08437001	1	カイヘイシ"ク	OPENING AND CLOSING MOTION SHAFT	
1-9	021080206	3	2シユナツト8	NUT 8	
1-10	048070342	1	トメフE7	STOP RING E7	
1-11	S08438001	1	アツシユクハ"ネ	SPRING	
1-12	S08439001	1	スライト"シ"ク	SLIDE SHAFT	
1-13	S08440000	1	ト"ライヘ"アリング"	BUSH BM1015FB	
1-14	S08441001	1	ストツハ"	STOPPER	
1-15	S08442001	1	レングツイタ	CONNECTING PLATE	
1-16	018502022	1	アナホ"ルト5X20	BOLT 5X20	
1-17	028050242	1	ハ"ネサ"カ"ネ2-5	SPRING WASHER 2-5	
1-18	S08443001	1	スライト"カ"イト"	SLIDE GUIDE	
1-19	073050002	1	シ"クウケナツトAN05	BEARING NUT AN05	
1-20	S08444000	2	ト"ライヘ"アリング"	BUSH BM1825FB	
1-21	S08445001	1	トリツケイタ	SET PLATE	
1-22	S08446000	1	シリンダ"クミ	CYLINDER ASSEMBLY	
1-22-1	S08447000	1	シリンダ"20X50	CYLINDER 20X50	
1-22-2	S04910000	2	ハーフユニオン	HALF UNION	
1-23	S08448001	1	ナツト	NUT	
1-24	018501622	2	アナホ"ルト5X16	BOLT 5X16	
1-25	028050242	2	ハ"ネサ"カ"ネ2-5	SPRING WASHER 2-5	
1-26	025050232	2	ヒラサ"カ"ネチユウ-5	PLAIN WASHER 5	
1-27	S08450009	1	スタツカー"ト"ダイ	STACKER BRACKET	
1-28	018082022	4	アナホ"ルト8X20	BOLT 8X20	
1-29	028080242	4	ハ"ネサ"カ"ネ2-8	SPRING WASHER 2-8	
1-30	025080232	4	ヒラサ"カ"ネチユウ 8	PLAIN WASHER 8	
1-31	149342001	2	ヒ"ロフ"ロツク	PILLOW BLOCK	
1-32	018081222	4	アナホ"ルト8X12	BOLT 8X12	
1-33	028080242	4	ハ"ネサ"カ"ネ2-8	SPRING WASHER 2-8	
1-34	025080232	4	ヒラサ"カ"ネチユウ 8	PLAIN WASHER 8	
1-35	S08514001	1	スタツカー"シテンシ"ク	STACKER FULCRUM SHAFT	
1-36	014060622	2	アナトメネシ"6X6クホ"ミ	SET SCREW 6X6	
1-37	S08449009	1	スタツカー"アーム	STACKER ARM	
1-38	S09406000	1	シリンダ"クミ	CYLINDER ASSEMBLY	
1-38-1	S09407000	1	シリンダ"25X150	CYLINDER 25X150	
1-38-2	S04910000	2	ハーフユニオン	HALF UNION	
1-39	149487001	1	リンク"ホ"ール	LINK BALL	
1-40	149488001	1	ロツト"ナツト	ROD NUT	
1-41	025100232	1	ヒラサ"カ"ネチユウ10	PLAIN WASHER 10	
1-42	028100243	2	ハ"ネサ"カ"ネ2-10	SPRING WASHER 2-10	
1-43	S09618001	1	シリンダ"トリツケカナク"	CYLINDER FITTING CLAMP	
1-44	S09619001	1	シリンダ"トリツケピン	PIN	
1-45	048050342	2	トメフE5	STOP RING E5	
1-46	018501622	2	アナホ"ルト5X16	BOLT 5X16	
1-47	028050242	2	ハ"ネサ"カ"ネ2-5	SPRING WASHER 2-5	
1-48	S15061009	1	キシ"ク"イアーム	CLOTH STACKER ARM	
1-49	018082022	2	アナホ"ルト8X20	BOLT 8X20	
1-50	028080242	2	ハ"ネサ"カ"ネ2-8	SPRING WASHER 2-8	
1-51	025080232	2	ヒラサ"カ"ネチユウ 8	PLAIN WASHER 8	
1-52	S08398009	1	スタツカー"テーブル"クミ	STACKER TABLE ASSEMBLY	
1-52-1	S08458009	1	スタツカー"テーブル"	STACKER TABLE	
1-52-2	S08459000	2	スタツカー"テーブル"ゴム	STACKER TABLE RUBBER	
1-53	052400806	6	ナ"コハ"ネヒラ4X8	WASHER SCREW 4X8	

K. スタッカー関係 / Stacker mechanism / Anhäufung /
 Mécanisme de l'empileur / Mecanismo de apilador

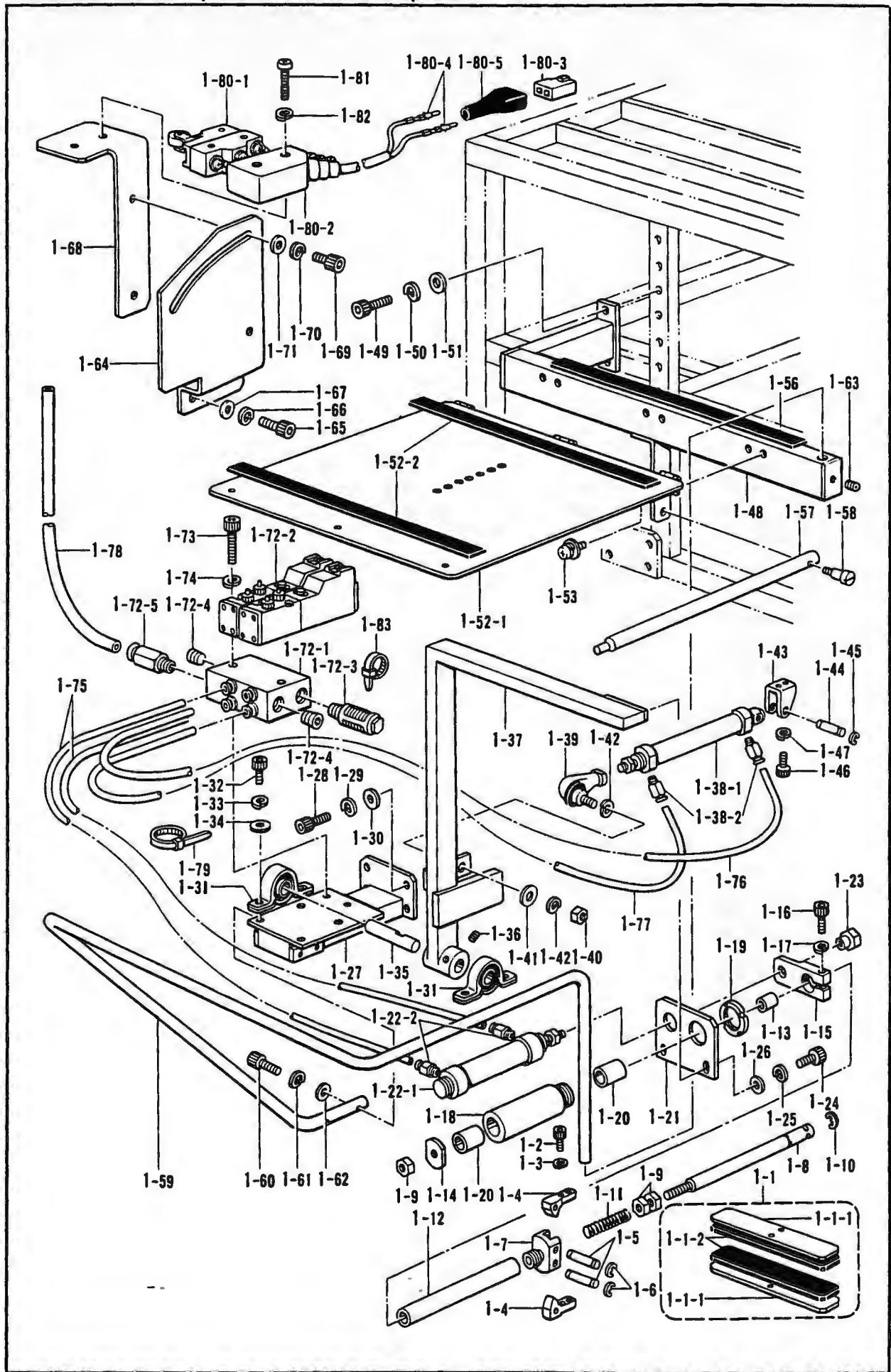

K. スタッカー関係 / Stacker mechanism / Anhäufung /
 Mécanisme de l'empileur / Mecanismo de apilador

REF.NO.	CODE	Q'TY	ヒンメイ	NAME OF PARTS	RMKS
1-56	S08459000	1	スタッカーテーブルゴム	STACKER TABLE RUBBER	
1-57	S08460001	1	テーブルササエ棒	TABLE SUPPORT BAR	
1-58	147933001	1	タムネジ5.95	STUD SCREW 5.95	
1-59	S15062009	1	ガードバー	GUARD BAR	
1-60	018062522	2	アナボルト6X25	BOLT 6X25	
1-61	028060242	2	ハネサカネ2-6	SPRING WASHER 2-6	
1-62	025060232	2	ヒラサカネチユウ 6	PLAIN WASHER 6	
1-63	014500522	1	アタメネジ5クホミ	SET SCREW 5	
1-64	S08470009	1	スタッカースイッチタイ	STACKER SWITCH BASE	
1-65	018061622	2	アナボルト6X16	BOLT 6X16	
1-66	028060242	2	ハネサカネ2-6	SPRING WASHER 2-6	
1-67	025060232	2	ヒラサカネチユウ 6	PLAIN WASHER 6	
1-68	S08471009	1	スタッカースイッチレバー	STACKER SWITCH LEVER	
1-69	018501022	2	アナボルト5X10	BOLT 5X10	
1-70	028050242	2	ハネサカネ2-5	SPRING WASHER 2-5	
1-71	025050232	2	ヒラサカネチユウ5	PLAIN WASHER 5	
1-72	S08135001	1	バルブユニットSTK	VALVE UNIT	
1-72-1	S08151000	1	マニホルトS-2	MANIFOLD S-2	
1-72-2	S08154000	2	バルブVZ3150	VALVE VZ3150	
1-72-3	140682001	1	サイレンサー	SILENCER	
1-72-4	153274001	2	1/8トメゼン	CAP 1/8	
1-72-5	S08152000	1	ハーフユニオン1/8-8	HALF UNION 1/8-8	
1-73	018503022	2	アナボルト5X30	BOLT 5X30	
1-74	028050242	2	ハネサカネ2-5	SPRING WASHER 2-5	
1-75	S08138000	2	エアホースS-A	AIR TUBE S-A	
1-76	S08139000	1	エアホースS-B	AIR TUBE S-B	
1-77	S08140000	1	エアホースS-C	AIR TUBE S-C	
1-78	S08361000	1	エアホース8-B	AIR TUBE 8-B	
1-79	S04557000	5	ハンタイPLTIM	BAND PLTIM	
1-80	S08127001	1	リミットスイッチクミ	LIMIT SWITCH ASSEMBLY	
1-80-1	S08131000	1	リミットスイッチ	LIMIT SWITCH	
1-80-2	147926000	1	マイクロスイッチカバー	MICRO SWITCH COVER	
1-80-3	S08007000	1	コネクタ5025-02P1	CONNECTOR 5025-02P1	
1-80-4	S08017000	2	オスピン5006TL	PIN	
1-80-5	143489001	1	コネクタキャップ	CONNECTOR CAP	
1-81	002402502	2	プラスナヘネジ4X25	SCREW 4X25	
1-82	028040242	2	ハネサカネ2-4	SPRING WASHER 2-4	
1-83	149809000	3	タイラップL	BEAD BAND (L)	

K. スタッカー関係/Stacker mechanism/Anhufung/
Mecanisme de l'empileur/Mecanismo de apilador

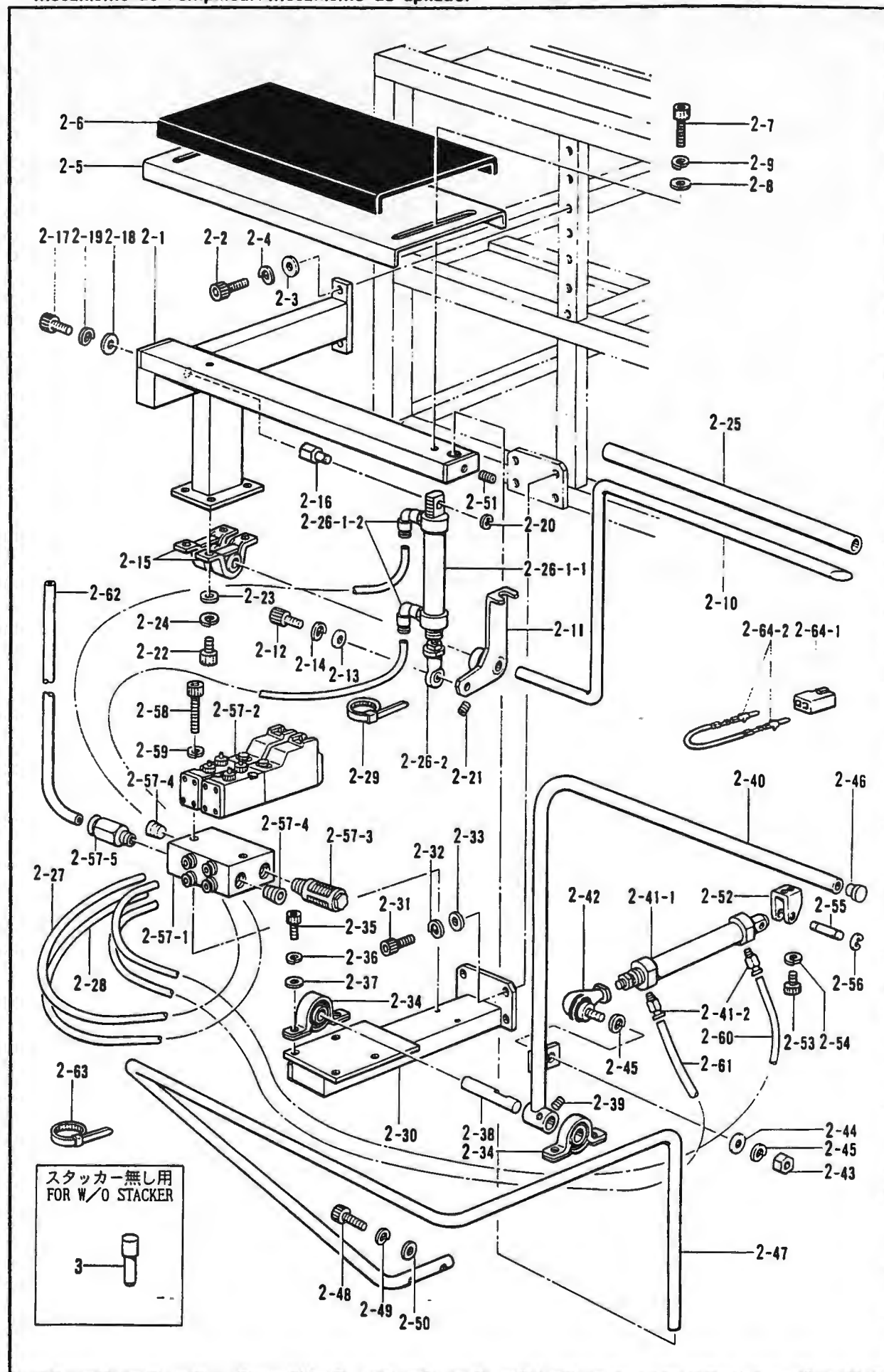

K. スタッカー関係/Stacker mechanism/Anhäufung/
Mécanisme de l'empileur/Mecanismo de apilador

REF NO.	CODE	Q'TY	ヒンメイ	NAME OF PARTS	RMKS
2	S08124109	1	バースタツカクミ	BAR STACKER ASSEMBLY	
2-1	S15063009	1	バースタツカーキシ"タイ	BAR STACKER CLOTH BASE	
2-2	018082022	2	アナホ"ルト8X20	BOLT 8X20	
2-3	025080232	2	ヒラサ"カ"ネチユウ 8	PLAIN WASHER 8	
2-4	028080242	2	ハ"ネサ"カ"ネ2-8	SPRING WASHER 2-8	
2-5	S06736009	1	スタツカーウケイタ	STACKER PLATE	
2-6	S06737000	1	スタツカスホ"ンシ"L	PACKING (L)	
2-7	018505022	2	アナホ"ルト5X50	BOLT 5X50	
2-8	025050232	2	ヒラサ"カ"ネチユウ-5	PLAIN WASHER 5	
2-9	028050242	2	ハ"ネサ"カ"ネ2-5	SPRING WASHER 2-5	
2-10	S15064001	1	スタツカーハ"-L	STACKER BAR (L)	
2-11	S06739009	1	スタツカーウチ"L	STACKER ARM (L)	
2-12	018082522	1	アナホ"ルト8X25	BOLT 8X25	
2-13	025080232	1	ヒラサ"カ"ネチユウ 8	PLAIN WASHER 8	
2-14	028080242	1	ハ"ネサ"カ"ネ2-8	SPRING WASHER 2-8	
2-15	S06740001	2	ヘ"アリング"ASPP202	BEARING ASPP202	
2-16	S06741001	1	シリンダ"トメカナク"	CYLINDER STUD	
2-17	018081222	1	アナホ"ルト8X12	BOLT 8X12	
2-18	025080232	1	ヒラサ"カ"ネチユウ 8	PLAIN WASHER 8	
2-19	028080242	1	ハ"ネサ"カ"ネ2-8	SPRING WASHER 2-8	
2-20	048060342	1	トメフE6	STOP RING E6	
2-21	014500522	2	アナトメネシ"5クホ"ミ	SET SCREW 5	
2-22	151163001	4	アナホ"ルト8X15	BOLT 8X15	
2-23	025080232	4	ヒラサ"カ"ネチユウ 8	PLAIN WASHER 8	
2-24	028080242	4	ハ"ネサ"カ"ネ2-8	SPRING WASHER 2-8	
2-25	S06744000	1	チューブ"L	AIR TUBE (L)	
2-26-1	S11685000	1	シリンダ"クミ	CYLINDER ASSEMBLY	
2-26-1-1	S06897000	1	シリンダ"20X75	CYLINDER 20X75	
2-26-1-2	S06886000	2	ツキ"テ1/8-4	JOINT 1/8-4	
2-26-2	S08352000	1	ロツト"エンド"	ROD END	
2-27	S08125000	1	エア-ホ-ス4-S1	AIR TUBE 4-S1	
2-28	S08126000	1	エア-ホ-ス4-S2	AIR TUBE 4-S2	
2-29	S04557000	2	ハンタイPLTIM	BAND PLTIM	
2-30	S15065009	1	スタツカー"タイ	STACKER BRACKET	
2-31	018082022	4	アナホ"ルト8X20	BOLT 8X20	
2-32	028080242	4	ハ"ネサ"カ"ネ2-8	SPRING WASHER 2-8	
2-33	025080232	4	ヒラサ"カ"ネチユウ 8	PLAIN WASHER 8	
2-34	149342001	2	ヒ"ロフ"ロツク	PILLOW BLOCK	
2-35	018081222	4	アナホ"ルト8X12	BOLT 8X12	
2-36	028080242	4	ハ"ネサ"カ"ネ2-8	SPRING WASHER 2-8	
2-37	025080232	4	ヒラサ"カ"ネチユウ 8	PLAIN WASHER 8	
2-38	S08514001	1	スタツカー"シチンシ"ク	STACKER FULCRUM SHAFT	
2-39	014060622	2	アナトメネシ"6X6クホ"ミ	SET SCREW 6X6	
2-40	S15066009	1	スタツカーハ"-	STACKER BAR	
2-41	S09406000	1	シリンダ"クミ	CYLINDER ASSEMBLY	
2-41-1	S09407000	1	シリンダ"25X150	CYLINDER 25X150	
2-41-2	S04910000	2	ハ-フユニオン	HALF UNION	
2-42	149487001	1	リンクホ"ール	LINK BALL	
2-43	149488001	1	ロツト"ナツト	ROD NUT	
2-44	025100232	1	ヒラサ"カ"ネチユウ10	PLAIN WASHER 10	
2-45	028100242	2	ハ"ネサ"カ"ネ2-10	SPRING WASHER 2-10	
2-46	117934009	1	メクラセン	OIL CAP	
2-47	S15062009	1	ガ-ト"ハ"-	GUARD BAR	
2-48	018062522	2	アナホ"ルト6X25	BOLT 6X25	
2-49	028060242	2	ハ"ネサ"カ"ネ2-6	SPRING WASHER 2-6	
2-50	025060232	2	ヒラサ"カ"ネチユウ 6	PLAIN WASHER 6	
2-51	014500522	1	アナトメネシ"5クホ"ミ	SET SCREW 5	
2-52	S09618001	1	シリンダ"トリツケカナク"	CYLINDER FITTING CLAMP	
2-53	018501622	2	アナホ"ルト5X16	BOLT 5X16	
2-54	028050242	2	ハ"ネサ"カ"ネ2-5	SPRING WASHER 2-5	
2-55	S09619001	1	シリンダ"トリツケピン	PIN	
2-56	048050342	2	トメフE5	STOP RING E5	

K. スタッカー関係 / Stacker mechanism / Anhäufung /
 Mécanisme de l'empileur / Mecanismo de apilador

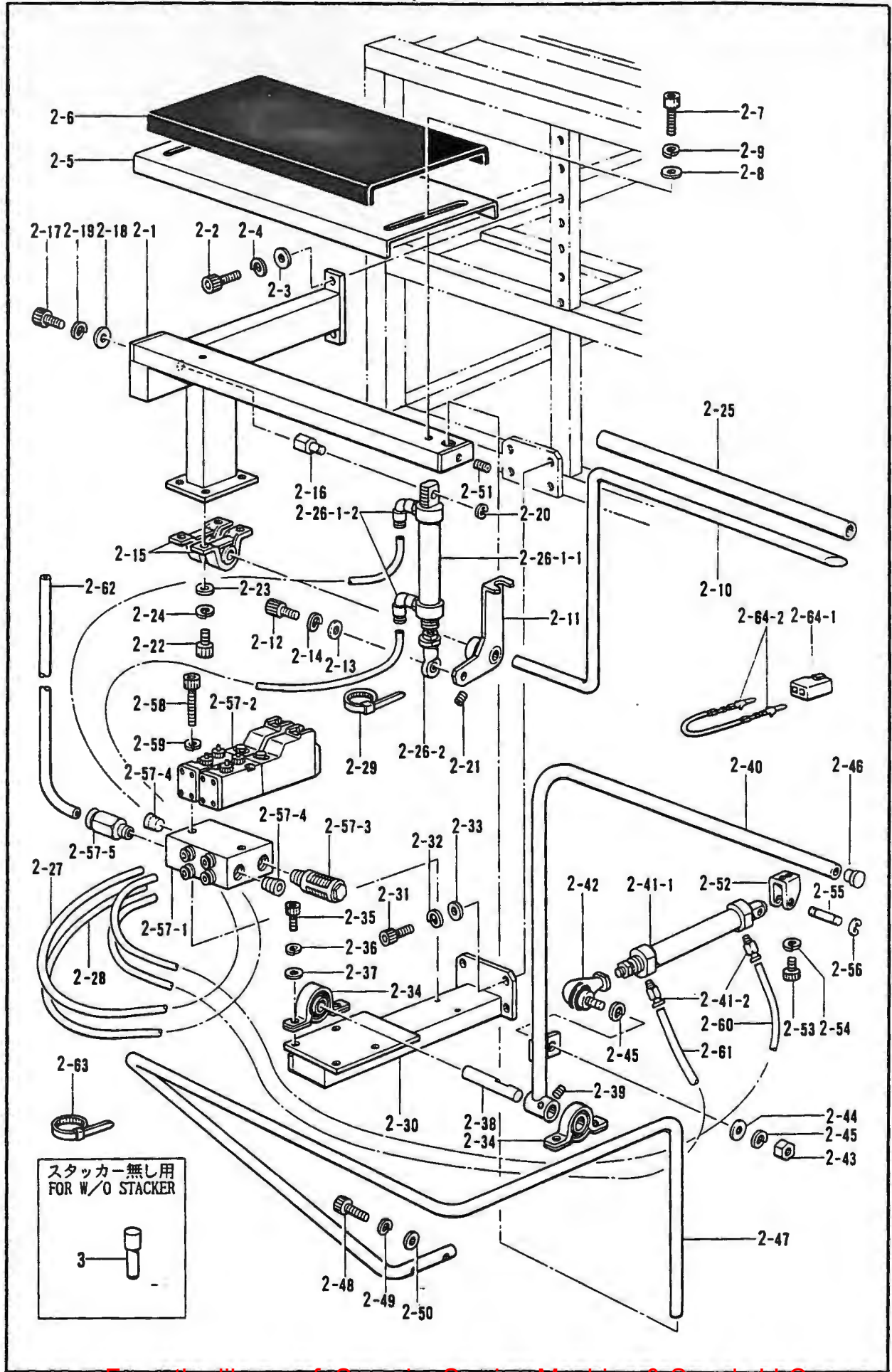

タッカー関係 / Stacker mechanism / Anhäufung /
 Mécanisme de l'empileur / Mecanismo de apilador

EF.NO.	CODE	Q'TY	ヒンメイ	NAME OF PARTS	RMKS
1	S08135001	1	バルブユニットSTK	VALVE UNIT	
2-57-1	S08151000	1	マニホルトS-2	MANIFOLD S-2	
57-2	S08154000	2	バルブVZ3150	VALVE VZ3150	
57-3	140682001	1	サイレンサー	SILENCER	
2-57-4	153274001	2	1/8トメセン	CAP 1/8	
2-57-5	S08152000	1	ハーフユニオン1/8-8	HALF UNION 1/8-8	
58	018503022	2	アナボルト5X30	BOLT 5X30	
59	028050242	2	ハネサガネ2-5	SPRING WASHER 2-5	
2-60	S08139000	1	エアホースS-B	AIR TUBE S-B	
2-61	S08140000	1	エアホースS-C	AIR TUBE S-C	
62	S08361000	1	エアホース8-B	AIR TUBE 8-B	
2-63	S04557000	4	バンドタイプPLTIM	BAND PLTIM.	
2-64	S08130000	1	コネクタ2Pクミ	CONNECTOR (2P) ASSEMBLY	
2-64-1	S08007000	1	コネクタ5025-02P1	CONNECTOR 5025-02P1	
2-64-2	S08017000	2	オスピン5006TL	PIN	
3	S08134000	1	トメセン8(スタツカーナシヨウ)	CAP 8 (FOR W/O STACKER)	

L. 糸巻関係 / Bobbin winder mechanism / Spuler /
Mécánisme du bobineur / Mecanismo del devanador de la canilla

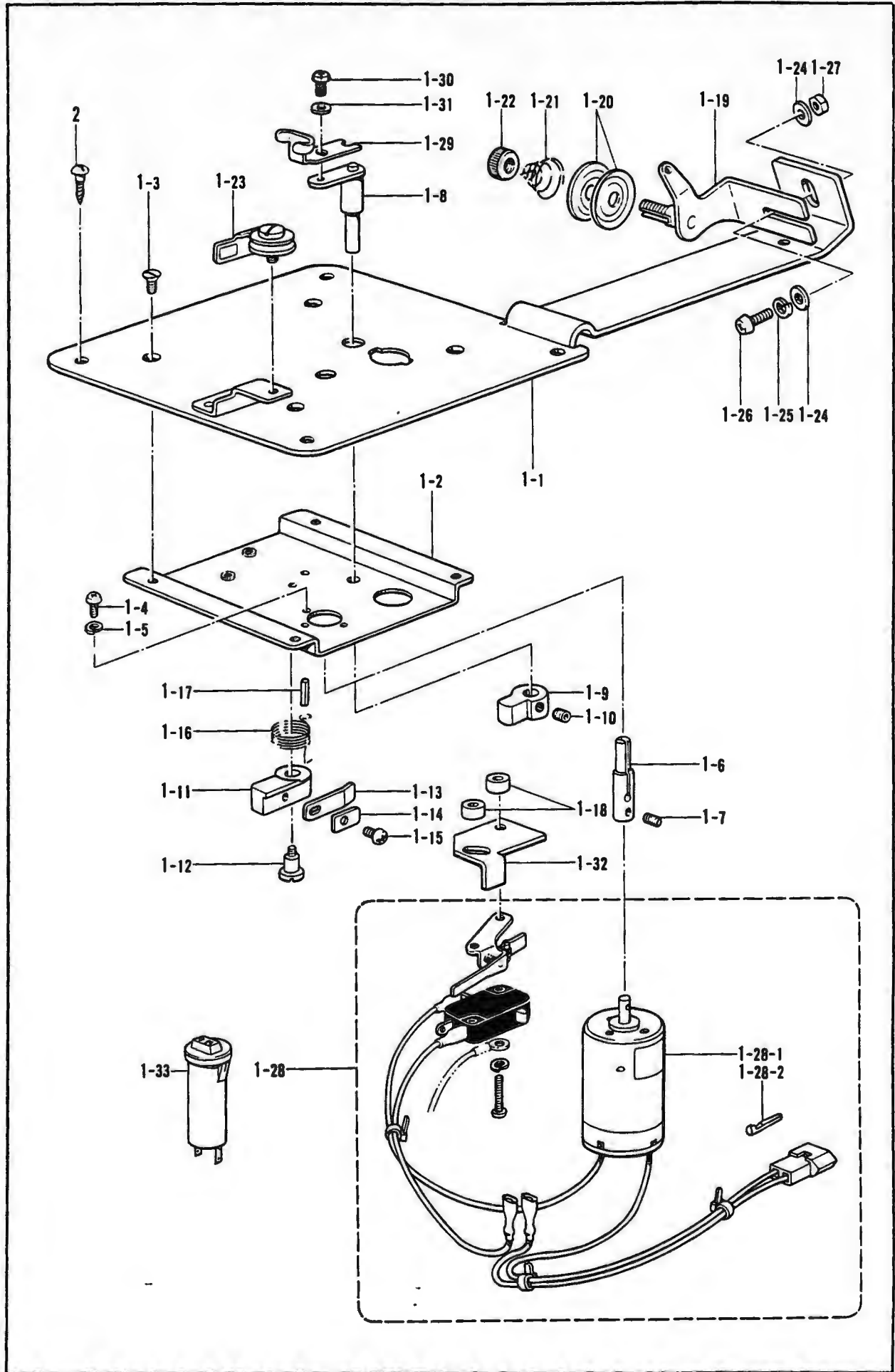

L. 糸巻関係/Bobbin winder mechanism/Spuler/
 Mécanisme du bobineur/Mecanismo del devanador de la canilla

REF NO.	CODE	Q'TY	ヒンメイ	NAME OF PARTS	RMKS
1	152651301	1	イトマキソウチクミ	BOBBIN WINDER ASSEMBLY	
1-1	152356301	1	イトマキト"タ"イ	BOBBIN WINDER BASE	
1-2	152357101	1	イトマキモーターシ"イタ	BOBBIN WINDER MOTOR INDICATE PLATE	
1-3	004300513	4	+サラネシ"3X5	SCREW 3X5	
1-4	062300606	3	ナヘ"3X6	SCREW 3X6	
1-5	028030242	3	ハ"ネサ"カ"ネ2-3	SPRING WASHER 2-3	
1-6	152358001	1	イトマキシク	BOBBIN WINDER SHAFT	
1-7	014300332	2	アナクホ"3X3	SET SCREW 3X3	
1-8	154024001	1	ホ"ヒ"ンオサエ	BOBBIN PRESSER	
1-9	154092001	1	イトマキツメタ"ンツキ	BOBBIN WINDER CLAW	
1-10	014680422	2	アタメネシ"4.37クホ"ミ	SET SCREW 4.37	
1-11	152361001	1	イトマキレハ"ー	BOBBIN WINDER LEVER	
1-12	152362001	1	イトマキダ"ンネシ"	BOBBIN WINDER STUD SCREW	
1-13	111942001	1	イタハ"ネ	PLATE SPRING	
1-14	111943001	1	イタハ"ネサ"カ"ネ	PLATE SPRING WASHER	
1-15	060660512	1	ハ"イント"318-40X5	SCREW 318X5	
1-16	152363001	1	ネシ"リハ"ネA	TWIST SPRING (A)	
1-17	047301042	1	スプ"リンク"ヒ"ン	SPRING PIN	
1-18	152364001	2	カラ"ー	COLLAR	
1-19	145571101	1	イトマキアンナイダ"イクミ	BOBBIN WINDER GUIDE BRACKET ASSEMBLY	
1-20	145446001	2	イトチヨウシサラ	TENSION DISC	
1-21	100401001	1	イトチヨウシハ"ネ	TENSION SPRING	
1-22	100136001	1	イトチヨウシナツト	TENSION NUT	
1-23	146197001	1	イトツカミクミ	THREAD CLAMP ASSEMBLY	
1-24	025040233	2	ヒラサ"カ"ネチユウ4	PLAIN WASHER 4	
1-25	028040243	1	ハ"ネサ"カ"ネ2-4	SPRING WASHER 2-4	
1-26	062401006	1	ナヘ"4X10	SCREW 4X10	
1-27	021400103	1	ナツト1シユ4	NUT 4	
1-28	S21203001	1	イトマキモータークミ	BOBBIN WINDER MOTOR ASSEMBLY	
1-28-1	S16667000	1	イトマキモーター	BOBBIN WINDER MOTOR	
1-28-2	552851001	2	ヒンターミナル#1854	TERMINAL PIN #1854	
1-29	152645001	1	ホ"ヒ"ンオサエイタ	BOBBIN HOLD PLATE	
1-30	062300606	1	ナヘ"3X6	SCREW 3X6	
1-31	025030233	1	ヒラサ"カ"ネチユウ3	PLAIN WASHER 3	
1-32	158597001	1	イトマキストツハ"ー	BOBBIN WINDER STOPPER	
1-33	S16669000	1	プロテクタ0.5A	PROTECTOR 0.5A	
2	032311306	5	+マルモクネシ"3.1X13	SCREW 3.1X13	

M. 糸切り関係 / Thread trimmer mechanism / Fadenabschneidevorrichtung /
 Mécanisme de coupe-fil / Mecanismo de la cortadura de hilos

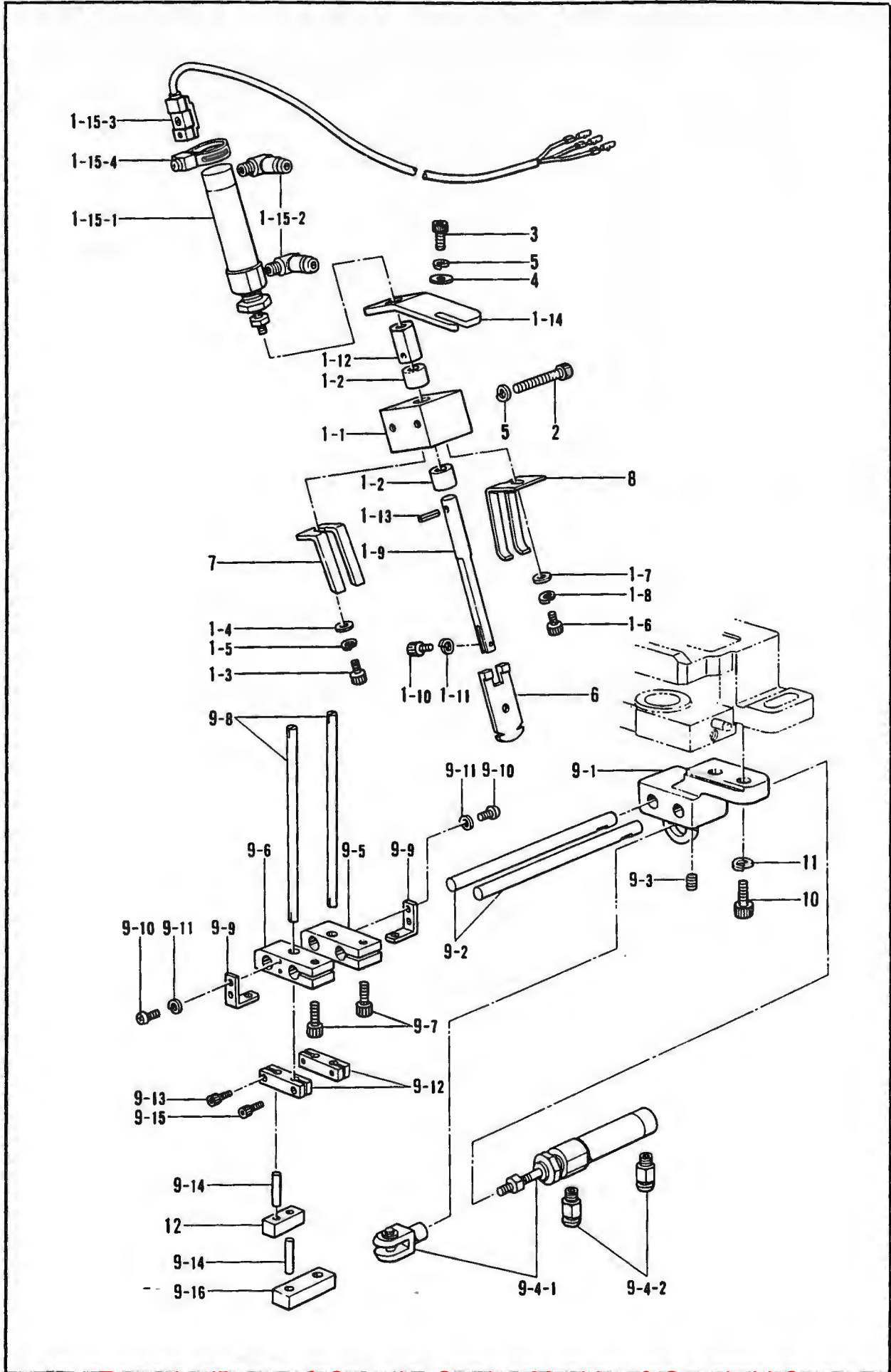

M. 糸切り関係 / Thread trimmer mechanism / Fadenabschneidevorrichtung /
 Mécanisme de coupe-fill / Mecanismo de la cortadura de hilos

REF NO	CODE	Q'TY	ヒンメイ	NAME OF PARTS	RMKS
1	S16146009	1	ウフイトメスクミ	UPPER THREAD KNIFE ASSEMBLY	
1-1	S14689001	1	メスホ"ウガ"イト	KNIFE BAR GUIDE	
1-2	S08397000	2	ト"ライヘ"アリング	BUSH BM0808FB	
1-3	018300822	1	アナホ"ルト3X8	BOLT 3X8	
1-4	025030133	1	ヒラサ"ガ"ネシヨウ3	PLAIN WASHER 3	
1-5	028030242	1	ハ"ネサ"ガ"ネ2-3	SPRING WASHER 2-3	
1-6	018300822	1	アナホ"ルト3X8	BOLT 3X8	
1-7	025030133	1	ヒラサ"ガ"ネシヨウ3	PLAIN WASHER 3	
1-8	028030242	1	ハ"ネサ"ガ"ネ2-3	SPRING WASHER 2-3	
1-9	S14802001	1	メスホ"ウ	KNIFE BAR	
1-10	018300822	1	アナホ"ルト3X8	BOLT 3X8	
1-11	028030242	1	ハ"ネサ"ガ"ネ2-3	SPRING WASHER 2-3	
1-12	S14690001	1	ツキ"テ	JOINT	
1-13	047301242	1	スプ"リング"ピンAW3	SPRING PIN AW3	
1-14	S14691009	1	シリンタ"ダイ	CYLINDER BRACKET	
1-15	S08406000	1	シリンタ"クミ	CYLINDER ASSEMBLY	
1-15-1	S08407000	1	シリンタ"16X30	CYLINDER 16X30	
1-15-2	S06883000	2	Sエルボ"M5-4	S-ELBOW M5-4	
1-15-3	S08488000	1	シリンタ"-センサ	CYLINDER SENSOR	
1-15-4	S08500000	1	ト"ツク"カナグ"16	FITTING CLAMP 16	
2	018403022	2	アナホ"ルト4X30	BOLT 4X30	
3	018401022	2	アナホ"ルト4X10	BOLT 4X10	
4	025040232	4	ヒラサ"ガ"ネチユウ4	PLAIN WASHER 4	
5	028040242	4	ハ"ネサ"ガ"ネ2-4	SPRING WASHER 2-4	
6	*	1	ウフイトメス	MOVABLE KNIFE	
7	*	1	コテイハ	FIXED KNIFE	
8	*	1	イトホシ"ハ"ネ	SPRING	
9	S16147001	1	シタイトメスクミ	LOWER THREAD KNIFE ASSEMBLY	
9-1	S14692001	1	メスト"ダイ	KNIFE BASE	
9-2	S08377001	2	ガ"イト"シ"ク	GUIDE SHAFT	
9-3	014400422	2	アナトメネシ"4X4クホ"ミ	SET SCREW 4X4	
9-4	S08387000	1	シリンタ"クミ	CYLINDER ASSEMBLY	
9-4-1	S08388000	1	シリンタ"16X15	CYLINDER 16X15	
9-4-2	S06882000	2	ツキ"テM5-4	JOINT M5-4	
9-5	S14693001	1	メスホルタ"R	KNIFE HOLDER (R)	
9-6	S14694001	1	メスホルタ"L	KNIFE HOLDER (L)	
9-7	018401222	2	アナホ"ルト4X12	BOLT 4X12	
9-8	S08381001	2	メス	KNIFE	
9-9	S08382001	2	ストツハ"	STOPPER	
9-10	062300616	4	ナヘ"コM3X6	SCREW M3X6	
9-11	028030243	4	ハ"ネサ"ガ"ネ2-3	SPRING WASHER 2-3	
9-12	S08383001	2	リンクA	LINK (A)	
9-13	018300622	2	アナホ"ルト3X6	BOLT 3X6	
9-14	S08384001	2	シ"ク4X19.8	SHAFT 4X19.8	
9-15	018300622	2	アナホ"ルト3X6	BOLT 3X6	
9-16	S08386001	1	リンクC	LINK (C)	
10	018501622	2	アナホ"ルト5X16	BOLT 5X16	
11	028050242	2	ハ"ネサ"ガ"ネ2-5	SPRING WASHER 2-5	
12	*	1	リンクB	LINK (B)	

N. コントロールボックス関係/Control box mechanism/Schaltkasten/
Mécanisme du boîtier de contrôle/Mecanismo del caja de controles

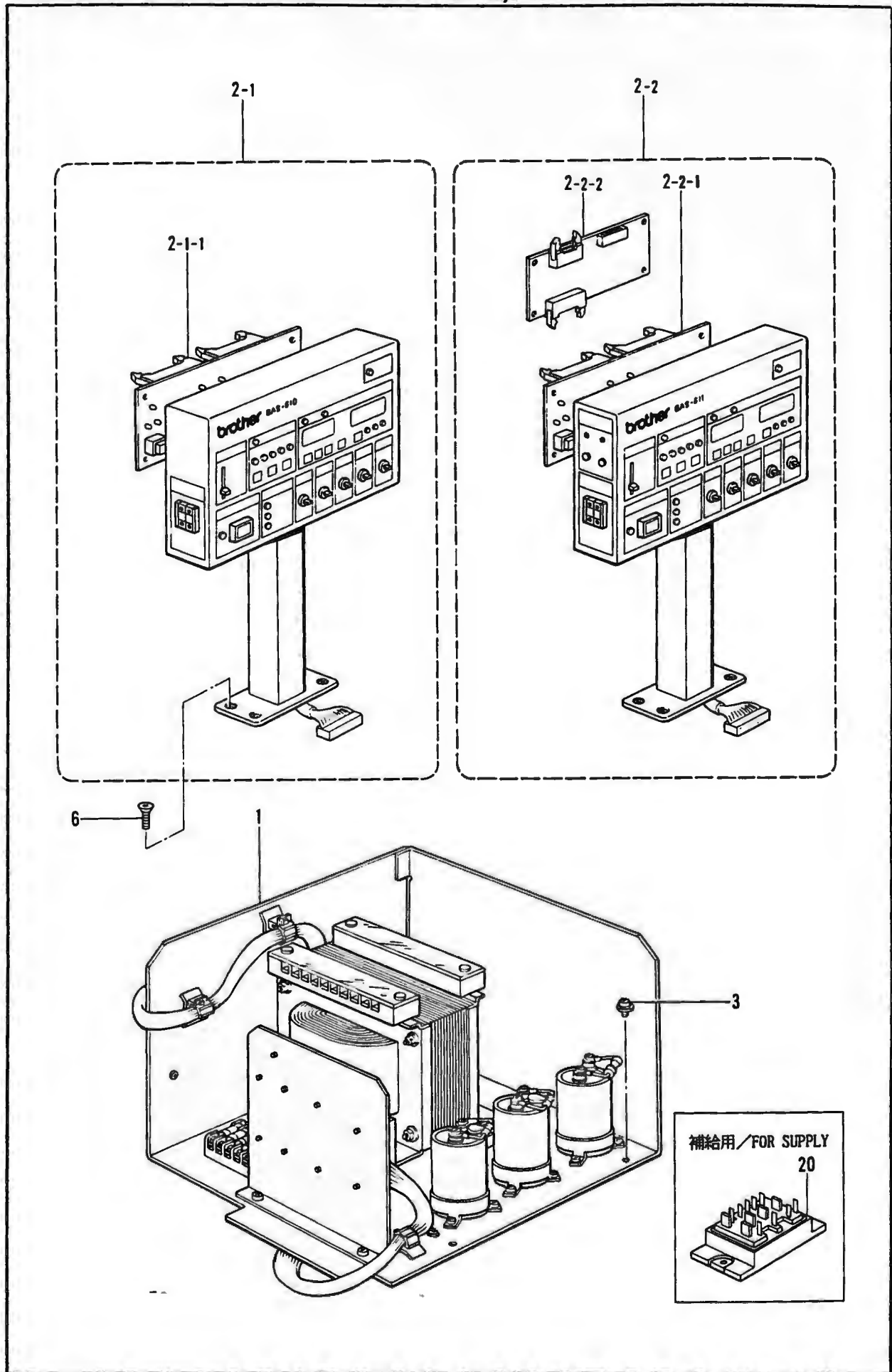

N. コントロールボックス関係/Control box mechanism/Schaltkasten/
Mécánisme du boítier de contrôle/Mecanismo del caja de controles

REF NO	CODE	Q'TY	ヒンメイ	NAME OF PARTS	RMKS
1	S08021201	1	デ"ンケ"ンユニットクミ (3ソウ)	POWER UNIT ASSEMBLY (3-PHASE)	
3	052400806	5	ナヘ"コハ"ネヒラ4X8	WASHER SCREW 4X8	
6	149320001	4	アナツキサラボ"ルトM6X40	BOLT M6X40	
< 610 >					
2-1	S15572109	1	ソウサホ"ツクスクミ	-----	
2-1	S15572110	1	-----	OPERATION BOX ASSEMBLY	
2-1-1	S08079000	1	キハ"ンB439011クミ	CIRCUIT BOARD (B439011) ASSEMBLY	
<フラップツケヨウ, FOR FLAP/611 >					
2-2	S15576109	1	ソウサホ"ツクスFクミ	-----	
2-2	S15576110	1	-----	OPERATION BOX (F) ASSEMBLY	
2-2-1	S08079000	1	キハ"ンB439011クミ	CIRCUIT BOARD (B439011) ASSEMBLY	
2-2-2	S08093000	1	キハ"ンB439012クミ	CIRCUIT BOARD (B439012) ASSEMBLY	
<オプション/OPTION PARTS >					
1	S16660101	1	デ"ンケ"ンユニットクミ (タンソウ)	POWER UNIT ASSEMBLY (1-PHASE)	
20	S08038000	1	TRアレイ6DI10A (ホキユウヨウ)	TR ALLEY 6DI10A (FOR SUPPLY)	

P. 空圧関係 / Air pressure mechanism / Luftdruck /
Mécanisme de la pression d'air / Mecanismo de la presión de aire

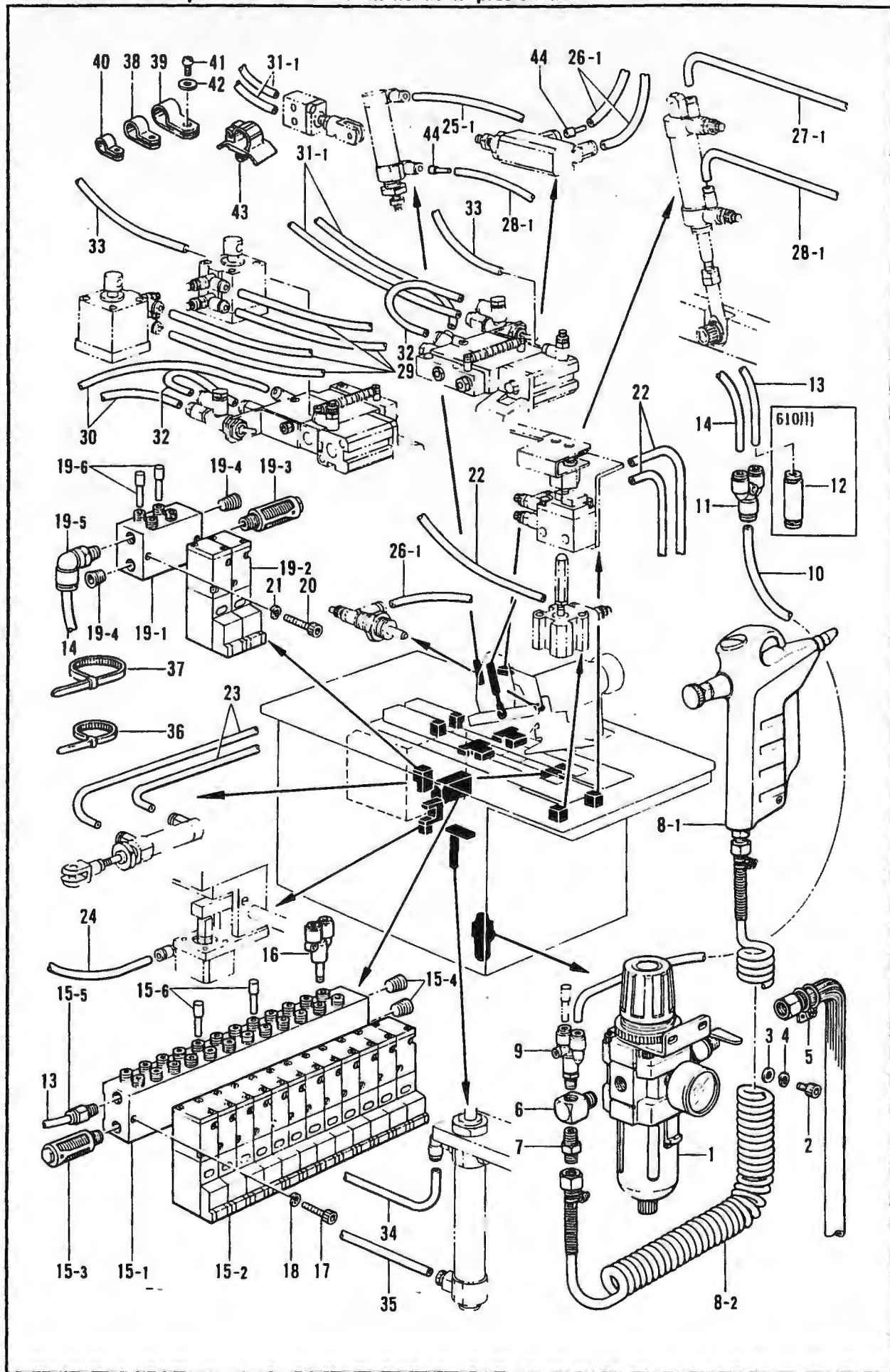

P. 空圧関係/Air pressure mechanism/Luftdruck/
Mécánisme de la pression d'air/Mecanismo de la presión de aire

REF NO	CODE	Q'TY	ヒンメイ	NAME OF PARTS	RMKS
1	S16162000	1	エアユニット	AIR UNIT	
2	018061222	2	アナボルト6X12	BOLT 6X12	
3	025060232	2	ヒラサ"カ"ネチユウ 6	PLAIN WASHER 6	
4	028060242	2	ハ"ネサ"カ"ネ2-6	SPRING WASHER 2-6	
5	149796001	1	ゴムホースカナク"ツキ	AIR TUBE WITH CONNECTOR	
6	153252000	1	PTチース"	PT-JOINT	
7	S04891000	1	チユウカンニツアル1/4	MIDDLE NIPPLE 1/4	
8	S06857000	1	エアガンクミ	AIR GUN ASSEMBLY	
8-1	S06858000	1	エアガン	AIR GUN	
8-2	S06859000	1	カールホース	CURL TUBE	
9	S08143000	1	ブ"ランチY1/4-8	BRANCH Y 1/4-8	
10	S08144000	1	エアホース8-A	AIR TUBE 8-A	
13	S08146000	1	エアホース6-A	AIR TUBE 6-A	
15	S15076101	1	ハ"ルフ"ユニット	VALVE UNIT	
15-1	S15077000	1	マニホルト"S-12	MANIFOLD S-12	
15-2	S08155000	12	ハ"ルフ"VZ3140	VALVE VZ3140	
15-3	140682001	1	サイレンサー	SILENCER	
15-4	153274001	2	1/8トメセン	CAP 1/8	
15-5	S01522000	1	ハーフユニオン	HALF UNION	
15-6	S04897000	2	メクラセン	BLIND CAP	
16	S08178000	3	ブ"ランチUY-4	BRANCH UY-4	
17	018503022	2	アナボルト5X30	BOLT 5X30	
18	028050242	2	ハ"ネサ"カ"ネ2-5	SPRING WASHER 2-5	
22	S08163000	3	エアホース4-B	AIR TUBE 4-B	
23	S08164000	2	エアホース4-C	AIR TUBE 4-C	
24	S08165000	1	エアホース4-D	AIR TUBE 4-D	
29	S08171000	4	エアホース4-J	AIR TUBE 4-J	
30	S08172000	2	エアホース4-K	AIR TUBE 4-K	
32	S08174000	2	エアホース4-M	AIR TUBE 4-M	
34	S08176000	1	エアホース4-O	AIR TUBE 4-O	
35	S08177000	1	エアホース4-P	AIR TUBE 4-P	
36	S04557000	17	ハ"ンタイPLTIM	BAND PLTIM	
37	149809000	2	タイラツフ"ル	BEAD BAND (L)	
38	554482000	2	コード"ホルダ"#12	CORD HOLDER (#12)	
39	S00470000	1	コード"ホルダ"#16	CORD HOLDER (#16)	
40	552907000	1	コード"ホルダ"#10	CORD HOLDER (#10)	
41	062401006	4	ナヘ"コ4X10	SCREW 4X10	
42	025040233	4	ヒラサ"カ"ネチユウ4	PLAIN WASHER 4	
43	S09141000	1	コード"クランプ"#16L	CORD CLAMP (#16L)	
44	S10557000	2	シボ"リノズル	THROTTLE NOZZLE	
<スタンダードヨウ / FOR STANDARD >					
25-1	S08166000	1	エアホース4-E	AIR TUBE 4-E	
26-1	S08167000	3	エアホース4-F	AIR TUBE 4-F	
27-1	S08168000	1	エアホース4-G	AIR TUBE 4-G	
28-1	S08169000	2	エアホース4-H	AIR TUBE 4-H	
31-1	S08173000	4	エアホース4-L	AIR TUBE 4-L	
< 610 >					
12	S08136000	1	イクイユニオン8-6	UNION 8-6	
<フラップツケヨウ, FOR FLAP/611 >					
11	S08145000	1	ユニオンY8-6	UNION Y 8-6	
14	S08147000	1	エアホース6-B	AIR TUBE 6-B	
19	S08159001	1	ハ"ルフ"ユニットFLP	VALVE UNIT (FOR FLAP)	
19-1	S08151000	1	マニホルト"S-2	MANIFOLD S-2	
19-2	S08155000	2	ハ"ルフ"VZ3140	VALVE VZ3140	
19-3	140682001	1	サイレンサー	SILENCER	
19-4	153274001	2	1/8トメセン	CAP 1/8	
19-5	S01542000	1	エルボ"ユニオン61	ELBOW UNION 61	
19-6	S04897000	2	メクラセン	BLIND CAP	
20	018503022	2	アナボルト5X30	BOLT 5X30	
21	028050242	2	ハ"ネサ"カ"ネ2-5	SPRING WASHER 2-5	
33	S08175000	2	エアホース4-N	AIR TUBE 4-N	

Q. 電装品関係/Power supply equipment mechanism/Stromversorgung/
Mécánisme de l'équipement en alimentation électrique/Mecanismo del equipo de alimentación de corriente

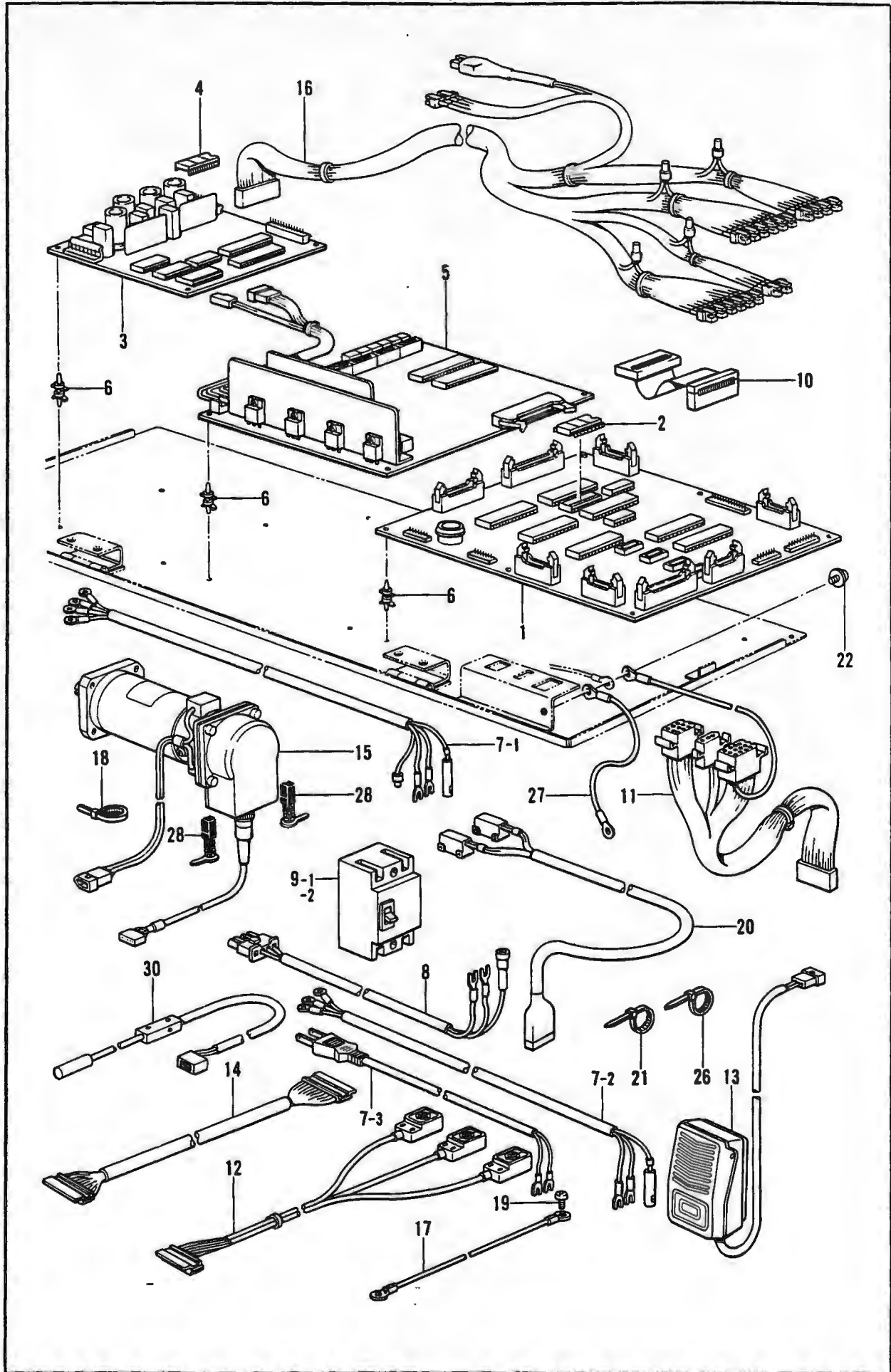

Q. 電装品関係 / Power supply equipment mechanism / Stromversorgung /
 Mécanisme de l'équipement en alimentation électrique / Mecanismo del equipo de alimentación de corriente

REF.NO.	CODE	Q'TY	ヒンメイ	NAME OF PARTS	RMKS
1	S14412000	1	キハ"ンB439048クミ	CIRCUIT BOARD (B439048) ASSEMBLY	
2	S14413000	1	PROM612-1クミ	PROM612-1 ASSEMBLY	
3	S15361001	1	キハ"ンB439049クミ	CIRCUIT BOARD (B439049) ASSEMBLY	
4	S08103000	1	PROM600-2クミ	PROM 600-2 ASSEMBLY	
5	S08098000	1	DCモータキハ"ンクミ	D.C.MOTOR CIRCUIT BOARD ASSEMBLY	
6	S00554000	14	サホ"ト6NS	SUPPORT 6NS	
7-1	S08086000	1	POWハーネスAクミ(3ソウ)	POWER HARNESS (A) ASSEMBLY (3-PHASE)	
8	S08105000	1	POWハーネスBクミ	POWER HARNESS (B) ASSEMBLY	
9-1	S08106000	1	ブレーカ5A(3ソウ)	BREAKER (5A) (3-PHASE)	
10	S08108000	1	PCBハーネス34Pクミ	PCB HARNESS 34P ASSEMBLY	
11	S08109000	1	PCBハーネス17Pクミ	PCB HARNESS 17P ASSEMBLY	
12	S08110000	1	キンセツスイッチクミ	PROXIMTY SWITCH ASSEMBLY	
13	S08114009	1	スタートSWクミ	START SWITCH ASSEMBLY	
14	S08115000	1	PCBハーネス15Pクミ	PCB HARNESS 15P ASSEMBLY	
15	S08116000	1	DCモータクミ	D.C.MOTOR ASSEMBLY	
16	S14414001	1	ハ"ルブ"ハーネスクミ	VALVE HARNESS ASSEMBLY	
17	S08113000	1	アースコート"	EARTH WIRE	
18	S04557000	3	ハ"ンタイPLTIM	BAND PLTIM	
19	062680616	1	ナハ"コ437-40X6	SCREW 437X6	
22	052400806	1	ナハ"コハ"ネヒラ4X8	WASHER SCREW 4X8	
27	S11337000	1	アースコート"	EARTH WIRE	
28	S11338000	1	DCモータブラシクミ	D.C. MOTOR BRUSH ASSEMBLY	
30	S14118000	1	コーナメスセンサクミ	CORNER KNIFE SENSOR ASSEMBLY	
<フラップツケヨウ, FOR FLAP/611 >					
20	S16612009	1	フラップセンサークミ	FLAP SENSOR ASSEMBLY	
21	S04557000	6	ハ"ンタイPLTIM	BAND PLTIM	
26	149809000	3	タイラツプL	BEAD BAND (L)	
<オプション (タンソウ) /OPTION PARTS (1-PHASE) >					
7-2	S16198000	1	-----	POWER HARNESS (A) ASSEMBLY	
7-3	S21575001	1	POWハーネスAクミ	-----	
9-2	S10287000	1	ブレーカ10A	BREAKER (10A)	

R. 布制御関係 / Cloth control system mechanism / Stoffführungsvorrichtung /
 Mécanisme de la système de contrôle du tissu / Mecanismo de la sistema de control de tela

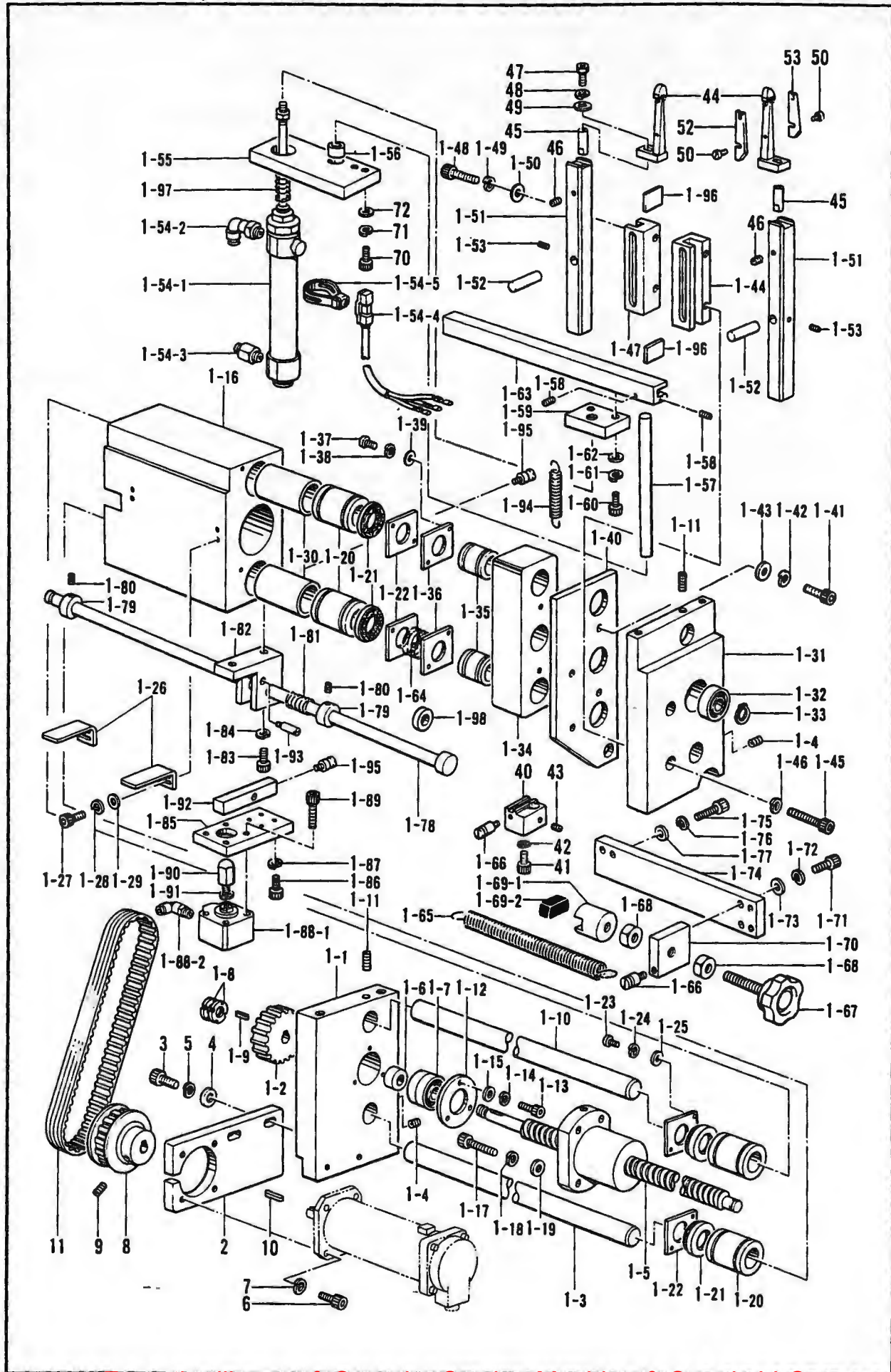

R. 布制御関係/Cloth control system mechanism/Stoffführungsvorrichtung/
 Mécanisme de la système de contrôle du tissu/Mecanismo de la sistema de control de tela

REF NO	CODE	QTY	ヒンメイ	NAME OF PARTS	RMKS
1	S08282101	1	オクソウチクミ	FEED DEVICE ASSEMBLY	
1-1	S08284001	1	ボールネジ"サホ"ートL	BALL SCREW SUPPORT (L)	
1-2	S08286000	1	タイミング"フー"リA	TIMING PULLEY (A)	
1-3	S08289001	1	スライ"シ"クシタ	SLIDE SHAFT LOWER	
1-4	014060622	2	アナメネシ"6X6クホ"ミ	SET SCREW 6X6	
1-5	S08290001	1	ボールネジ"	BALL SCREW	
1-6	S08291001	1	カラー	COLLAR	
1-7	S08292000	1	タマジ"クウケ7201ADF	BALL BEARING 7201ADF	
1-8	073010002	2	シ"クウケナツトAN01	BEARING NUT AN01	
1-9	S08280000	1	キー4X4X16	KEY 4X4X16	
1-10	S08293001	1	スライ"シ"クウエ	SLIDE SHAFT UPPER	
1-11	014060622	2	アナメネシ"6X6クホ"ミ	SET SCREW 6X6	
1-12	S08294001	1	ヘ"アリング"オサエ	BEARING PRESSER	
1-13	018401222	3	アナボ"ルト4X12	BOLT 4X12	
1-14	028040242	3	ハ"ネサ"カ"ネ2-4	SPRING WASHER 2-4	
1-15	025040232	3	ヒラサ"カ"ネチユウ4	PLAIN WASHER 4	
1-16	S08295000	1	オオオサエイト"ウタ"イ	CARRIAGE FEED MOVABLE BASE	
1-17	018062522	4	アナボ"ルト6X25	BOLT 6X25	
1-18	028060242	4	ハ"ネサ"カ"ネ2-6	SPRING WASHER 2-6	
1-19	025060232	4	ヒラサ"カ"ネチユウ 6	PLAIN WASHER 6	
1-20	S09157000	4	リニアボ"ールヘ"アリング"	LINEAR BALL BEARING	
1-21	S08400000	4	フェルトシール	FELT SEAL	
1-22	S08300001	4	ヘ"アリング"オサエ	BEARING PRESSER	
1-23	062300616	8	ナヘ"コM3X6	SCREW M3X6	
1-24	028030243	8	ハ"ネサ"カ"ネ2-3	SPRING WASHER 2-3	
1-25	025030233	8	ヒラサ"カ"ネチユウ3	PLAIN WASHER 3	
1-26	S08301001	2	センサー"カンチイタ	SENSOR PERCEIVE PLATE	
1-27	018300822	4	アナボ"ルト3X8	BOLT 3X8	
1-28	028030242	4	ハ"ネサ"カ"ネ2-3	SPRING WASHER 2-3	
1-29	025030232	4	ヒラサ"カ"ネチユウ3	PLAIN WASHER 3	
1-30	S08304001	2	スヘ"ーサ	SPACER	
1-31	S14799001	1	ボールネジ"サホ"ートR	BALL SCREW SUPPORT (R)	
1-32	S08306000	1	タマジ"クウケ6201ZZ	BALL BEARING 6201ZZ	
1-33	048120142	1	トメワシ"クヨウC12	STOP RING C12	
1-34	S21225000	1	コーナメスイト"ウタ"イ	CORNER KNIFE MOVABLE BASE	
1-35	S21224000	2	リニアボ"ールヘ"アリング"	LINEAR BALL BEARING	
1-36	S08300001	2	ヘ"アリング"オサエ	BEARING PRESSER	
1-37	062300616	4	ナヘ"コM3X6	SCREW M3X6	
1-38	028030243	4	ハ"ネサ"カ"ネ2-3	SPRING WASHER 2-3	
1-39	025030233	4	ヒラサ"カ"ネチユウ3	PLAIN WASHER 3	
1-40	S21407001	1	コーナメスタ"イ	CORNER KNIFE BASE	
1-41	018501622	2	アナボ"ルト5X16	BOLT 5X16	
1-42	028050242	2	ハ"ネサ"カ"ネ2-5	SPRING WASHER 2-5	
1-43	025050232	2	ヒラサ"カ"ネチユウ-5	PLAIN WASHER 5	
1-44	S08317001	1	スライ"カ"イト"R	SLIDE GUIDE (R)	
1-45	018503022	2	アナボ"ルト5X30	BOLT 5X30	
1-46	028050242	2	ハ"ネサ"カ"ネ2-5	SPRING WASHER 2-5	
1-47	S08318001	1	スライ"カ"イト"L	SLIDE GUIDE (L)	
1-48	018502022	2	アナボ"ルト5X20	BOLT 5X20	
1-49	028050242	2	ハ"ネサ"カ"ネ2-5	SPRING WASHER 2-5	
1-50	025050232	2	ヒラサ"カ"ネチユウ-5	PLAIN WASHER 5	
1-51	S14754001	2	スライ"タ"ー	SLIDER	
1-52	S08320001	2	オシアケ"ピン	PIN	
1-53	014400422	2	アナメネシ"4X4クホ"ミ	SET SCREW 4X4	
1-54	S08323000	1	シリン"ク"クミ	CYLINDER ASSEMBLY	
1-54-1	S08324000	1	シリン"ク"20X75	CYLINDER 20X75	
1-54-2	S06866000	1	ハ"ル"フ	VALVE	
1-54-3	S04910000	1	ハーフユニオン	HALF UNION	
1-54-4	S08488000	1	シリン"ク"センサー	CYLINDER SENSOR	
1-54-5	S08501000	1	トリツク"カナク"20	FITTING CLAMP 20	
1-55	S08325001	1	シリン"ク"トリツク"ク"イ	CYLINDER FITTING BASE	
1-56	S08326000	1	ト"ライ"ヘ"アリング"	BUSH BM0812FB	

R. 布制御関係 / Cloth control system mechanism / Stoffführungsvorrichtung /
 Mécanisme de la système de contrôle du tissu / Mecanismo de la sistema de control de tela

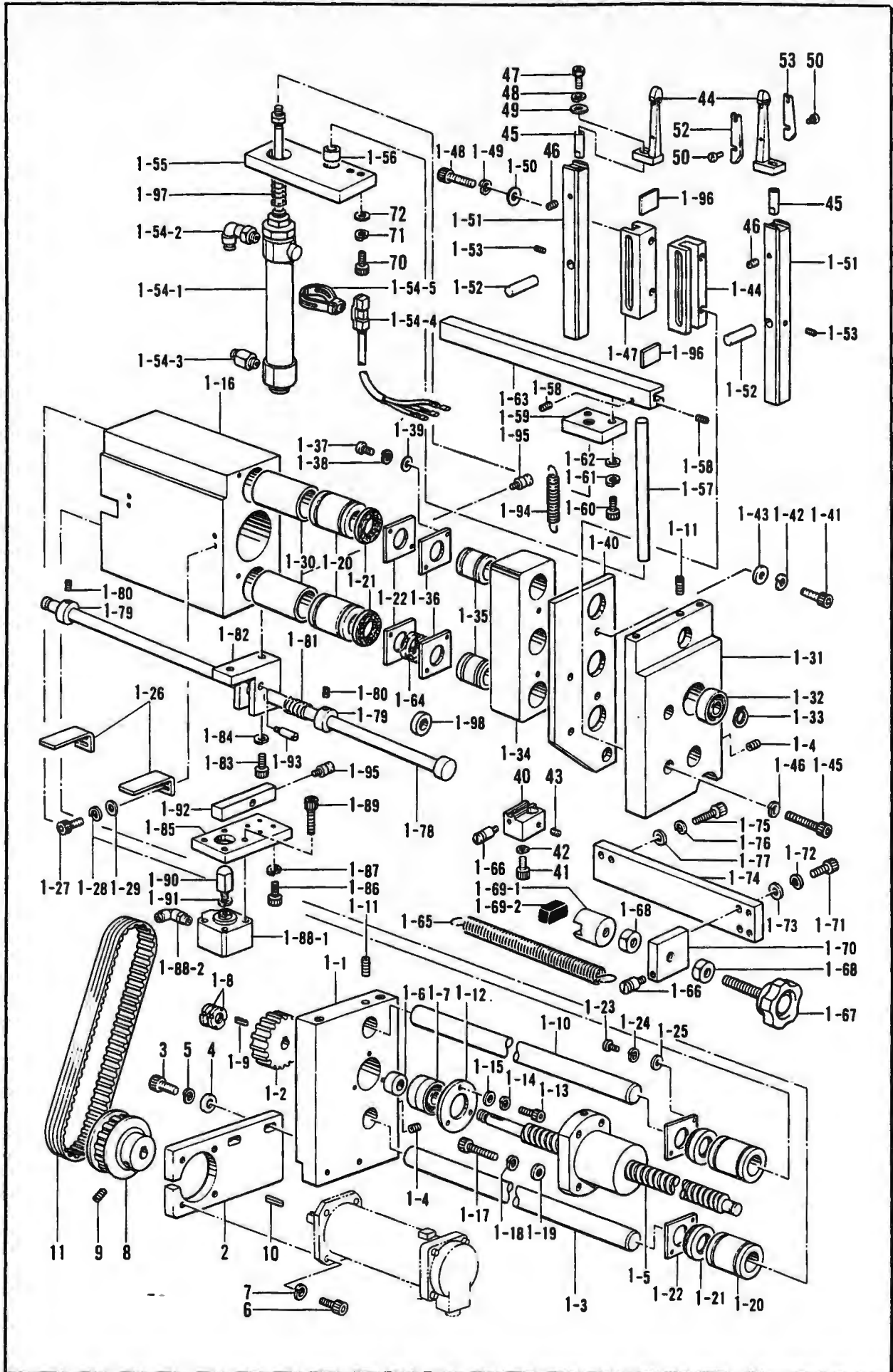

R. 布制御関係/Cloth control system mechanism/Stoffführungsvorrichtung/
 Mécanisme de la système de contrôle du tissu/Mecanismo de la sistema de control de tela

REF.NO	CODE	Q'TY	ヒンメイ	NAME OF PARTS	RMKS
1-57	S08327001	1	マフリト"メシ"ク	BAFFLE WHIRL-STOP SHAFT	
1-58	014500522	2	アナトメネシ"5クホ"ミ	SET SCREW 5	
1-59	S08328001	1	シリンダ"レンゲツイタ	CYLINDER CONNECTING PLATE	
1-60	018501622	2	アナホ"ルト5X16	BOLT 5X16	
1-61	028050242	2	ハ"ネサ"カ"ネ2-5	SPRING WASHER 2-5	
1-62	025050232	2	ヒラサ"カ"ネチユウ-5	PLAIN WASHER 5	
1-63	S08329001	1	コーナ-メスオシアケ"イタ	CORNER KNIFE LIFTING PLATE	
1-64	S08303001	1	アツシユクハ"ネ	SPRING	
1-65	S08308001	1	ヒツハ"リハ"ネ	SPRING	
1-66	S08509001	2	ハ"ネカケ	SPRING HOOK	
1-67	S08180000	1	ノブ"ホ"ルトM8X50	NOB BOLT M8X50	
1-68	021080206	2	2シユナツト8	NUT 8	
1-69	S09155000	1	マグ"ネットホルダ"ークミ	MAGNET HOLDER ASSEMBLY	
1-69-1	S09156000	1	マグ"ネットホルダ"	MAGNET HOLDER	
1-69-2	112525000	1	シユウシ"ンマグ"ネット	MAGNET	
1-70	S15201001	1	ハント"ルダ"イ	HANDLE BASE	
1-71	018061622	2	アナホ"ルト6X16	BOLT 6X16	
1-72	028060242	2	ハ"ネサ"カ"ネ2-6	SPRING WASHER 2-6	
1-73	025060232	2	ヒラサ"カ"ネチユウ 6	PLAIN WASHER 6	
1-74	S09153001	1	チヨウセツタ"イ	ADJUST BASE	
1-75	018502022	2	アナホ"ルト5X20	BOLT 5X20	
1-76	028050242	2	ハ"ネサ"カ"ネ2-5	SPRING WASHER 2-5	
1-77	025050232	2	ヒラサ"カ"ネチユウ-5	PLAIN WASHER 5	
1-78	S08297001	1	イチキ"メロツト"	POSITIONING ROD	
1-79	S08296001	2	セツトカラ-	SET COLLAR	
1-80	014500522	4	アナトメネシ"5クホ"ミ	SET SCREW 5	
1-81	148555001	1	シユレハ"ーモト"シハ"ネ	SPRING	
1-82	S15590001	1	クランプ"ダ"イ	CLAMP BASE	
1-83	018501422	2	アナホ"ルト5X14	BOLT 5X14	
1-84	028050242	2	ハ"ネサ"カ"ネ2-5	SPRING WASHER 2-5	
1-85	S13638001	1	シリンダ"トリツケイタ	CYLINDER SET PLATE	
1-86	018401622	4	アナホ"ルト4X16	BOLT 4X16	
1-87	028040242	4	ハ"ネサ"カ"ネ2-4	SPRING WASHER 2-4	
1-88	S13639000	1	シリンダ"クミ	CYLINDER ASSEMBLY	
1-88-1	S13640000	1	シリンダ"32X10	CYLINDER 32X10	
1-88-2	S06886000	1	ツキ"テ1/8-4	JOINT 1/8-4	
1-89	018062022	4	アナホ"ルト6X20	BOLT 6X20	
1-90	S13641001	1	プ"ツシヤ	PUSHER	
1-91	028060242	1	ハ"ネサ"カ"ネ2-6	SPRING WASHER 2-6	
1-92	S15591001	1	クランプ"レハ"ー	CLAMP LEVER	
1-93	S08315000	1	シデンシ"ク	FULCRUM SHAFT	
1-94	156292001	1	ストツハ"ーヒキハ"ネ	SPRING	
1-95	S08509001	2	ハ"ネカケ	SPRING HOOK	
1-96	S09170000	2	クツシヨシ"コム	RUBBER CUSHION	
1-97	S09685101	1	アツシユクハ"ネ	SPRING	
1-98	S15202001	1	センサ"スヘ"ーサ	SENSOR SPACER	
2	S08285001	1	モ-ター"フ"ラケツト	MOTOR BRACKET	
3	018062522	2	アナホ"ルト6X25	BOLT 6X25	
4	025060232	2	ヒラサ"カ"ネチユウ 6	PLAIN WASHER 6	
5	028060242	2	ハ"ネサ"カ"ネ2-6	SPRING WASHER 2-6	
6	018501622	4	アナホ"ルト5X16	BOLT 5X16	
7	028050242	4	ハ"ネサ"カ"ネ2-5	SPRING WASHER 2-5	
8	S08287000	1	タイミン"ク"プ-ーリB	TIMING PULLEY (B)	
9	014501222	2	アナトメネシ"5X12ヒラ	SET SCREW 5X12	
10	S10540000	1	キー"3X3X20	KEY 3X3X20	
11	S08288000	1	タイミン"ク"ヘ"ルト	TIMING BELT	
40	S15203000	1	センサ"フ"ラケツト	SENSOR BRACKET	
41	018402522	1	アナホ"ルト4X25	BOLT 4X25	
42	028040242	1	ハ"ネサ"カ"ネ2-4	SPRING WASHER 2-4	
43	014300332	1	アナクホ"ミ3X3	SET SCREW 3X3	
44	*	2	メスタ"イクミ	KNIFE BASE ASSEMBLY	
45	S14753001	2	メスタ"イシ"ク	KNIFE BASE SHAFT	

R. 布制御関係 / Cloth control system mechanism / Stoffführungsvorrichtung /
 Mécanisme de la système de contrôle du tissu / Mecanismo de la sistema de control de tela

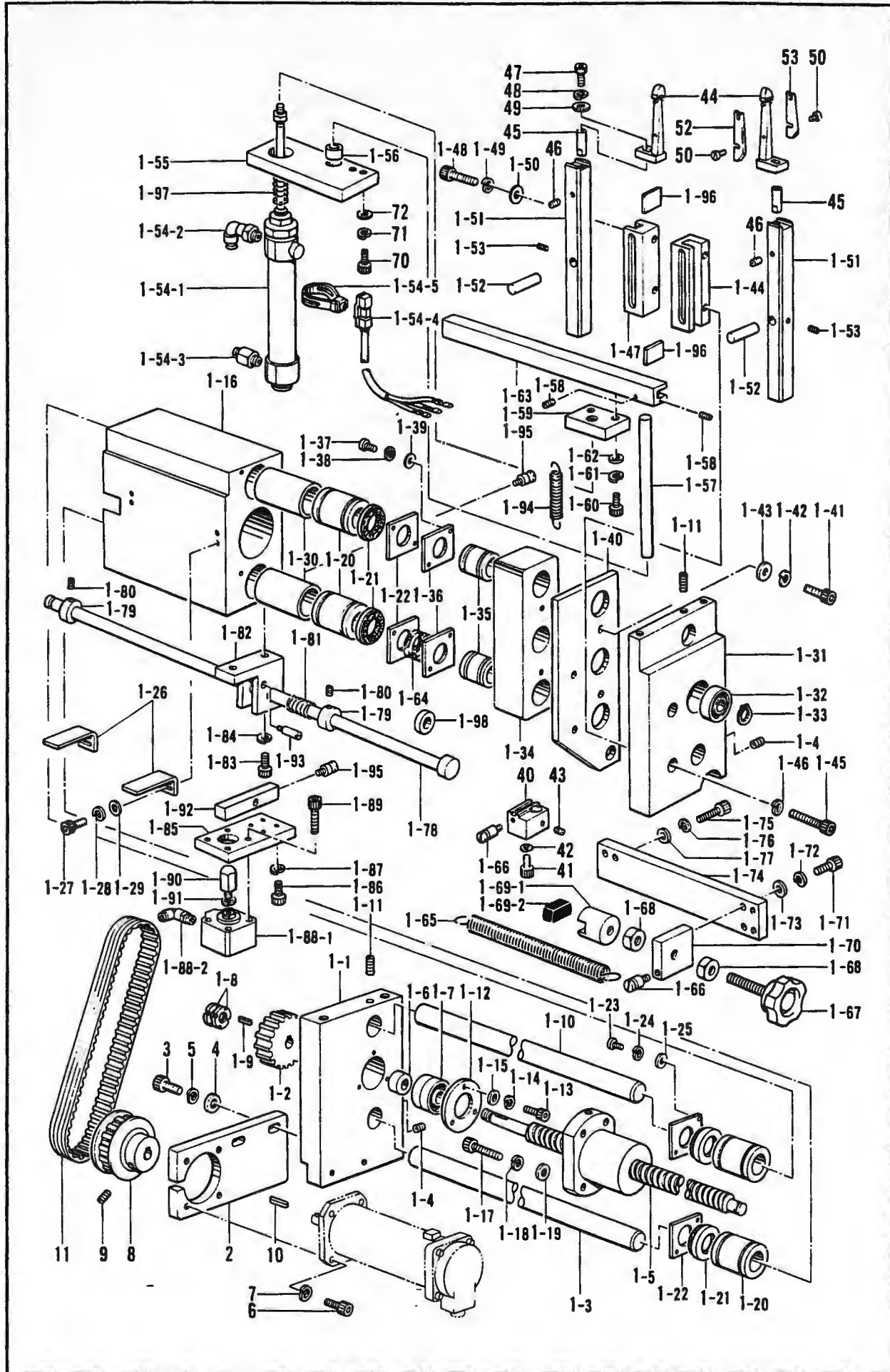

R. 布制御関係 / Cloth control system mechanism / Stoffführungsvorrichtung /
 Mécanisme de la système de contrôle du tissu / Mecanismo de la sistema de control de tela

REF NO	CODE	Q'TY	ヒンメイ	NAME OF PARTS	RMKS
46	014400422	2	アナトメネジ"4X4クボ"三	SET SCREW 4X4	
47	018401222	2	アナボ"ルト4X12	BOLT 4X12	
48	028040242	2	ハ"ネサ"カ"ネ2-4	SPRING WASHER 2-4	
49	025040232	2	ヒラサ"カ"ネチユウ4	PLAIN WASHER 4	
50	111140002	4	シメネジ"2.38	SCREW 2.38	
52	*	2	コーナーメス	CORNER KNIFE	
53	*	2	コーナーメス	CORNER KNIFE	
70	018062522	2	アナボ"ルト6X25	BOLT 6X25	
71	028060242	2	ハ"ネサ"カ"ネ2-6	SPRING WASHER 2-6	
72	025060232	2	ヒラサ"カ"ネチユウ6	PLAIN WASHER 6	

R. 布制御関係/Cloth control system mechanism/Stoffführungsvorrichtung/
 Mécanisme de la système de contrôle du tissu/Mecanismo de la sistema de control de tela

REF.NO.	CODE	Q'TY	ヒンメイ	NAME OF PARTS	RMKS
12	S15814109	1	メンイタユニットクミ	FACE PLATE UNIT ASSEMBLY	
12-1	S15815001	1	メンイタ	FACE PLATE	
12-2	S14700001	1	アーム	ARM	
12-3	S08332000	1	ト"ライヘ"アリンク"	BUSH BM1212FB	
12-4	S08238000	2	スラストヘ"アリンク"	THRUST BEARING	
12-5	S08239000	2	スラストワッシャ	THRUST WASHER	
12-6	S08240000	2	スラストワッシャ	THRUST WASHER	
12-7	S08342001	1	スラストヘ"アリンク"カハ"	THRUST BEARING COVER	
12-8	S08333001	1	シテンシ"ク	FULCRUM SHAFT	
12-9	021120304	1	ナット3シユ12	NUT 12	
12-10	S08360001	1	シリンダ"トリツケシ"ク	CYLINDER FITTING SHAFT	
12-11	021080206	1	2シユナット8	NUT 8	
12-12	028080242	1	ハ"ネサ"カ"ネ2-8	SPRING WASHER 2-8	
12-13	025080232	1	ヒラサ"カ"ネチユウ8	PLAIN WASHER 8	
12-14	048040342	1	トメフE4	STOP RING E4	
12-15	S08335000	1	シリンダ"クミ	CYLINDER ASSEMBLY	
12-15-1	S08336000	1	シリンダ"20X35	CYLINDER 20X35	
12-15-2	S06898000	2	スピ"コンツキ"テ1/8-4	SPEED CONTROLLER JOINT 1/8-4	
12-16	S08352000	1	ロツト"イント"	ROD END	
12-17	018082522	1	アナボ"ルト8X25	BOLT 8X25	
12-18	028080242	1	ハ"ネサ"カ"ネ2-8	SPRING WASHER 2-8	
12-19	025080232	2	ヒラサ"カ"ネチユウ8	PLAIN WASHER 8	
12-20	S08341009	1	シ"ヨウキ"シテンシ"ク	BINDER FULCRUM SHAFT	
12-21	S08338001	1	ヨアツナツト	PRE-LOAD NUT	
12-22	S08339001	1	ユルミト"メ	LOOSENESS STOPPER	
12-23	014060622	1	アナトメネシ"6X6クホ"ミ	SET SCREW 6X6	
12-24	S08332000	1	ト"ライヘ"アリンク"	BUSH BM1212FB	
12-25	S08238000	2	スラストヘ"アリンク"	THRUST BEARING	
12-26	S08239000	2	スラストワッシャ	THRUST WASHER	
12-27	S08240000	2	スラストワッシャ	THRUST WASHER	
12-28	S08334001	1	ヘ"アリンク"カハ"	BEARING COVER	
12-29	S08340001	1	セツトカラ	SET COLLAR	
12-30	014060622	1	アナトメネシ"6X6クホ"ミ	SET SCREW 6X6	
12-31	S08343000	1	カムフオロフ	CAM FOLLOWER	
12-32	028050242	1	ハ"ネサ"カ"ネ2-5	SPRING WASHER 2-5	
12-33	025050232	1	ヒラサ"カ"ネチユウ5	PLAIN WASHER 5	
12-34	S08344001	1	カムフオロフトリツケホ"ウ	CAM FOLLOWER SET BAR	
12-35	018501622	2	アナボ"ルト5X16	BOLT 5X16	
12-36	028050242	2	ハ"ネサ"カ"ネ2-5	SPRING WASHER 2-5	
12-37	S08345001	1	シ"ヨウキ"トリツケイタA	BINDER FITTING PLATE (A)	
12-38	018062022	1	アナボ"ルト6X20	BOLT 6X20	
12-39	028060242	1	ハ"ネサ"カ"ネ2-6	SPRING WASHER 2-6	
12-40	025060232	1	ヒラサ"カ"ネチユウ6	PLAIN WASHER 6	
12-41	018501622	2	アナボ"ルト5X16	BOLT 5X16	
12-42	028050242	2	ハ"ネサ"カ"ネ2-5	SPRING WASHER 2-5	
12-43	025050232	2	ヒラサ"カ"ネチユウ5	PLAIN WASHER 5	
12-44	S08346001	1	シ"ヨウキ"トリツケイタB	BINDER FITTING PLATE (B)	
12-45	018501622	2	アナボ"ルト5X16	BOLT 5X16	
12-46	028050242	2	ハ"ネサ"カ"ネ2-5	SPRING WASHER 2-5	
12-47	S08347009	1	シ"ヨウキ"トリツケイタC	BINDER FITTING PLATE (C)	
12-48	S08348001	1	イタハ"ネタイ	PLATE SPRING BRACKET	
12-49	018301222	2	アナボ"ルト3X12	BOLT 3X12	
12-50	028030242	2	ハ"ネサ"カ"ネ2-3	SPRING WASHER 2-3	
12-51	S08349001	1	イタハ"ネ	PLATE SPRING	
12-52	018301222	1	アナボ"ルト3X12	BOLT 3X12	
12-53	021300303	2	ナット3シユ3	NUT 3	
12-54	S08350001	2	セツトカラ	SET COLLAR	
12-55	014400422	4	アナトメネシ"4X4クホ"ミ	SET SCREW 4X4	
12-56	S08356001	*	スヘ"ーサ	SPACER	
12-57	S14801001	1	キシ"カ"イト"アームR	CLOTH GUIDE ARM (R)	
12-58	S14800001	1	キシ"カ"イト"アームL	CLOTH GUIDE ARM (L)	
12-59	018301222	2	アナボ"ルト3X12	BOLT 3X12	

R. 布制御関係/Cloth control system mechanism/Stoffführungsvorrichtung/
 Mécanisme de la système de contrôle du tissu/Mecanismo de la sistema de control de tela

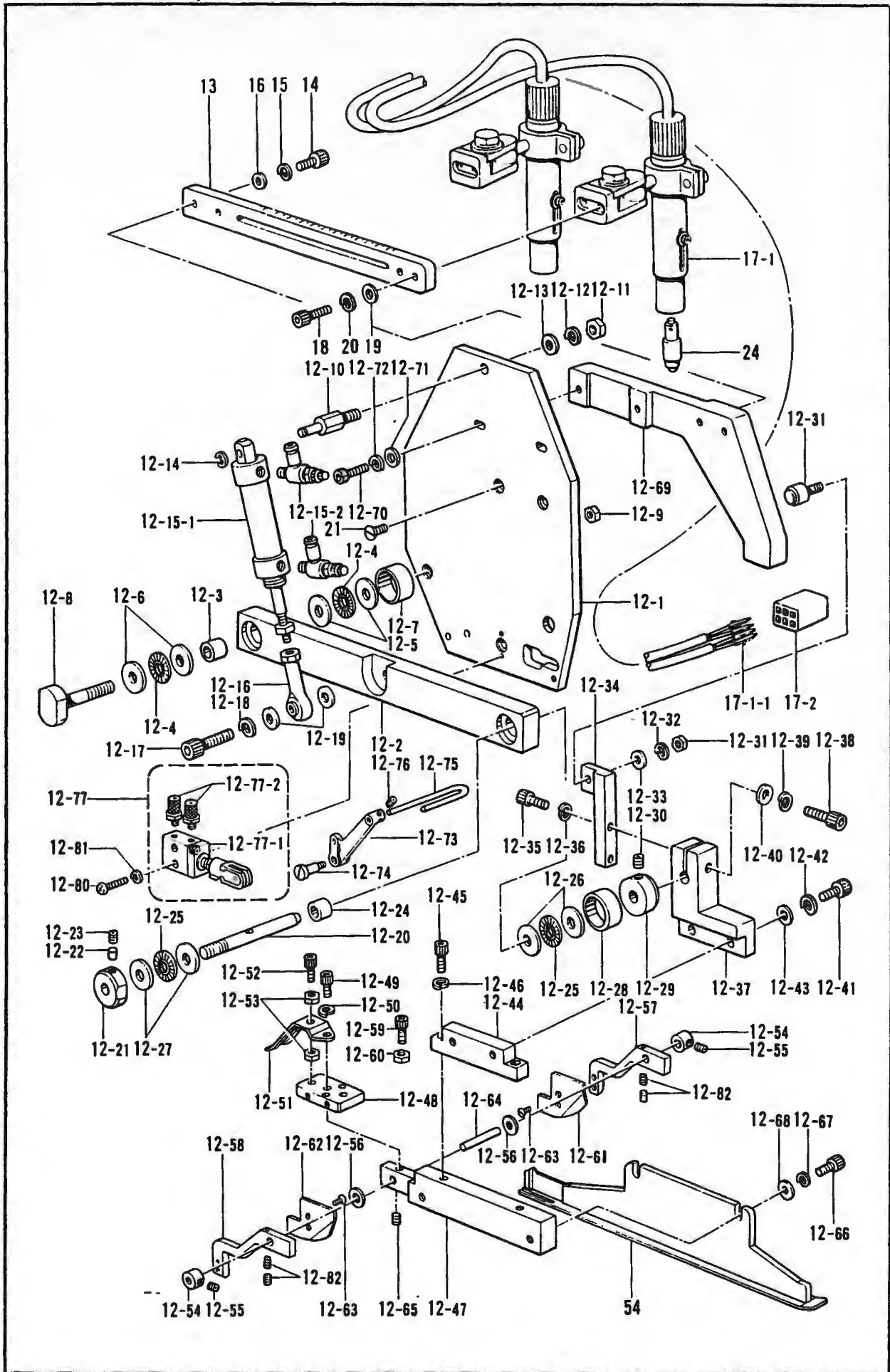

R. 布制御関係/Cloth control system mechanism/StoffführungsVorrichtung/
 Mécanisme de la système de contrôle du tissu/Mecanismo de la sistema de control de tela

REF NO	CODE	Q'TY	ヒンメイ	NAME OF PARTS	RMKS
12-60	021300303	2	ナツト3シユ3	NUT 3	
12-61	S18944000	1	キシ"ガイ"ト"R	CLOTH GUIDE (R)	
12-62	S18945000	1	キシ"ガイ"ト"L	CLOTH GUIDE (L)	
12-63	061020506	4	サラコ2X5	SCREW 2X5	
12-64	S08355001	1	シデンシ"ク	FULCRUM SHAFT	
12-65	014400422	1	アナトメネシ"4X4クホ"ミ	SET SCREW 4X4	
12-66	018501222	2	アナホ"ルト5X12	BOLT 5X12	
12-67	028050242	2	ハ"ネサ"カ"ネ2-5	SPRING WASHER 2-5	
12-68	146354001	2	サ"カ"ネ	WASHER	
12-69	S08364009	1	ミソ"カム	FLUTE CAM	
12-70	018501622	2	アナホ"ルト5X16	BOLT 5X16	
12-71	025050232	2	ヒラサ"カ"ネチユウ5	PLAIN WASHER 5	
12-72	028050242	2	ハ"ネサ"カ"ネ2-5	SPRING WASHER 2-5	
12-73	S14703001	1	イトクリタ"シウヂ"	THREAD TAKE-UP ARM	
12-74	141598001	1	タ"ンネシ"4.76	STUD SCREW 4.76	
12-75	S08372001	1	イトクリタ"シ	THREAD TAKE-UP	
12-76	014300332	2	アナクホ"ミ3X3	SET SCREW 3X3	
12-77	S14704200	1	シリンダ"クミ	CLINDER ASSEMBLY	
12-77-1	S14705000	1	シリンダ"10X5	CYLINDER 10X5	
12-77-2	S19900000	2	コテイシホ"リツキツキ"ヂ	THROTTLE TUBE JOINT	
12-80	062301605	2	ナヘ"コ 3X16	SCREW 3X16	
12-81	028030243	2	ハ"ネサ"カ"ネ2-3	SPRING WASHER 2-3	
12-82	014300522	4	トメネシ"3X5クホ"ミ	SET SCREW 3X5	
13	S08365001	1	ランプト"タイ	LAMP BRACKET	
14	018501622	2	アナホ"ルト5X16	BOLT 5X16	
15	028050242	2	ハ"ネサ"カ"ネ2-5	SPRING WASHER 2-5	
16	025050232	2	ヒラサ"カ"ネチユウ5	PLAIN WASHER 5	
17	S08502000	1	マーキング"ライトクミ	MARKING LIGHT ASSEMBLY	
17-1	S08367000	2	ライトマーカ	MARKING LIGHT	
17-1-1	S08017000	2	オスピン5006TL	PIN	
17-2	S08009000	1	コネクタ5025-06P1	CONNECTOR 5025-06P1	
18	018502022	4	アナホ"ルト5X20	BOLT 5X20	
19	025050232	4	ヒラサ"カ"ネチユウ5	PLAIN WASHER 5	
20	028050242	4	ハ"ネサ"カ"ネ2-5	SPRING WASHER 2-5	
21	S01698001	3	サラネシ"5 95X12	SCREW 5.95X12	
24	S08137000	1	ランプ"5W	LAMP 5W	
54	*	1	シ"ヨウキ"クミ	BINDER ASSEMBLY	

R. 布制御関係 / Cloth control system mechanism / Stoffführungsvorrichtung /
 Mécanisme de la système de contrôle du tissu / Mecanismo de la sistema de control de tela

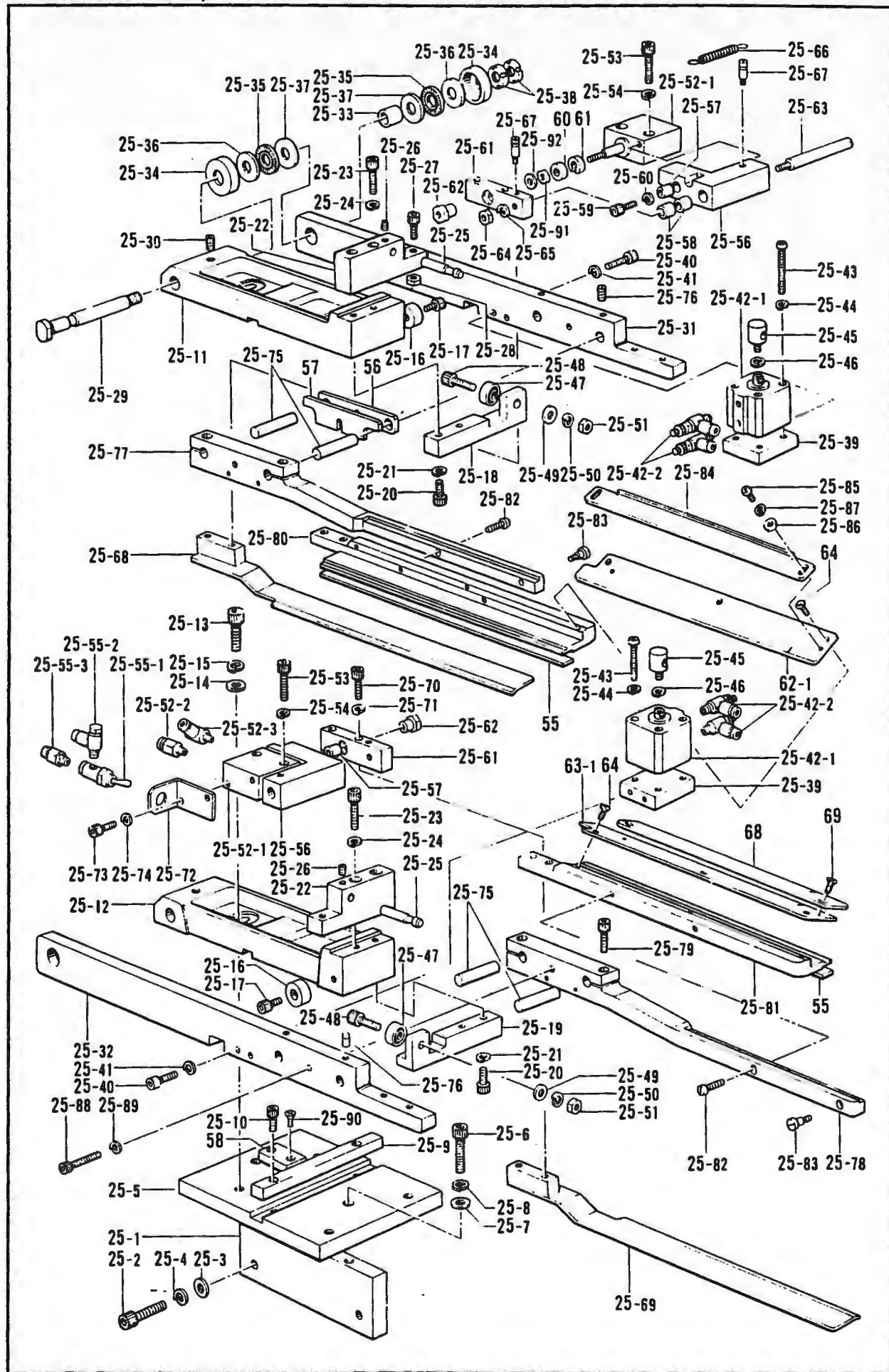

R. 布制御関係/Cloth control system mechanism/Stoffführungsvorrichtung/
 Mécanisme de la système de contrôle du tissu/Mecanismo de la sistema de control de tela

REF NO	CODE	QTY	ヒンメイ	NAME OF PARTS	RMKS
25	S08227001	1	オオオサイクミ	CARRIAGE FEED ASSEMBLY	
25-1	S08228001	1	オオオサエトリツクイタ	CARRIAGE FEED FITTING PLATE	
25-2	018083022	2	アナホ"ルト8X30	BOLT 8X30	
25-3	025080232	2	ヒラサ"カ"ネチユウ 8	PLAIN WASHER 8	
25-4	028080242	2	ハ"ネサ"カ"ネ2-8	SPRING WASHER 2-8	
25-5	S08229001	1	オオオサエトリツクタイ	CARRIAGE FEED FITTING BASE	
25-6	018083022	2	アナホ"ルト8X30	BOLT 8X30	
25-7	025080232	2	ヒラサ"カ"ネチユウ 8	PLAIN WASHER 8	
25-8	028080242	2	ハ"ネサ"カ"ネ2-8	SPRING WASHER 2-8	
25-9	S08230001	1	スライ"カ"イト	SLIDE GUIDE	
25-10	018401022	2	アナホ"ルト4X10	BOLT 4X10	
25-11	S08231000	1	オオオサエイト"ウダ"イR	CARRIAGE FEED MOVABLE BASE (R)	
25-12	S08232000	1	オオオサエイト"ウダ"イL	CARRIAGE FEED MOVABLE BASE (L)	
25-13	018082522	4	アナホ"ルト8X25	BOLT 8X25	
25-14	025080232	4	ヒラサ"カ"ネチユウ 8	PLAIN WASHER 8	
25-15	028080242	4	ハ"ネサ"カ"ネ2-8	SPRING WASHER 2-8	
25-16	S08233000	2	スヘ"リ"カ"イト	SLIDE GUIDE	
25-17	018501022	2	アナホ"ルト5X10	BOLT 5X10	
25-18	S08245001	1	カ"イト"ローラ"イR	GUIDE ROLLER BASE (R)	
25-19	S08246001	1	カ"イト"ローラ"イL	GUIDE ROLLER BASE (L)	
25-20	018501422	4	アナホ"ルト5X14	BOLT 5X14	
25-21	028050242	4	ハ"ネサ"カ"ネ2-5	SPRING WASHER 2-5	
25-22	S08248001	2	レンクツジ"クササエ	CONNECTING SHAFT SUPPORT	
25-23	018502522	4	アナホ"ルト5X25	BOLT 5X25	
25-24	028050242	4	ハ"ネサ"カ"ネ2-5	SPRING WASHER 2-5	
25-25	S08247001	2	オサエロツト"	PRESSER ROD	
25-26	014500522	2	アナトメネジ"5クホ"ミ	SET SCREW 5	
25-27	018502022	2	アナホ"ルト5X20	BOLT 5X20	
25-28	021500103	2	ナツト1シユ5	NUT 5	
25-29	S08234001	2	シテンシ"ク	FULCRUM SHAFT	
25-30	014501222	2	アナトメネジ"5X12ヒラ	SET SCREW 5X12	
25-31	S08217001	1	オオオサエウチ"R	CARRIAGE FEED ARM (R)	
25-32	S08235001	1	オオオサエウチ"L	CARRIAGE FEED ARM (L)	
25-33	S08332000	2	ト"ライハ"アリング"	BUSH BM1212FB	
25-34	S08237001	4	スラストハ"アリング"カハ"	THRUST BEARING COVER	
25-35	S08238000	4	スラストハ"アリング"	THRUST BEARING	
25-36	S08239000	4	スラストワツシヤ	THRUST WASHER	
25-37	S08240000	4	スラストワツシヤ	THRUST WASHER	
25-38	073010002	4	シ"クウクナツトAN01	BEARING NUT AN01	
25-39	S08241001	2	シリンダ"ーウケ	CYLINDER SUPPOT	
25-40	018502022	4	アナホ"ルト5X20	BOLT 5X20	
25-41	028050242	4	ハ"ネサ"カ"ネ2-5	SPRING WASHER 2-5	
25-42	S08242000	2	シリンダ"クミ	CYLINDER ASSEMBLY	
25-42-1	S08252000	2	シリンダ"20X15	CYLINDER 20X15	
25-42-2	S08498000	4	スピコンツキ"チM5-4	SPEED CONTROLLER JOINT M5-4	
25-43	062304006	8	ナヘ"コ3X40	SCREW 3X40	
25-44	028030243	8	ハ"ネサ"カ"ネ2-3	SPRING WASHER 2-3	
25-45	S08142001	2	レンクツジ"ク	CONNECTING SHAFT	
25-46	028040243	2	ハ"ネサ"カ"ネ2-4	SPRING WASHER 2-4	
25-47	S08249000	2	ハ"アリング"MR626ZZ	BEARING MR626ZZ	
25-48	018062022	2	アナホ"ルト6X20	BOLT 6X20	
25-49	025060232	2	ヒラサ"カ"ネチユウ 6	PLAIN WASHER 6	
25-50	028060242	2	ハ"ネサ"カ"ネ2-6	SPRING WASHER 2-6	
25-51	021060206	2	2シユナツト6	NUT 6	
25-52	S08250000	2	シリンダ"クミ	CYLINDER ASSEMBLY	
25-52-1	S08251000	2	シリンダ"16X20	CYLINDER 16X20	
25-52-2	S06882000	2	ツキ"チM5-4	JOINT M5-4	
25-52-3	S06883000	2	Sエルボ"M5-4	S-ELBOW M5-4	
25-53	018402522	4	アナホ"ルト4X25	BOLT 4X25	
25-54	028040242	4	ハ"ネサ"カ"ネ2-4	SPRING WASHER 2-4	

R. 布制御関係/Cloth control system mechanism/Stoffführungsvorrichtung/
 Mécanisme de la système de contrôle du tissu/Mecanismo de la sistema de control de tela

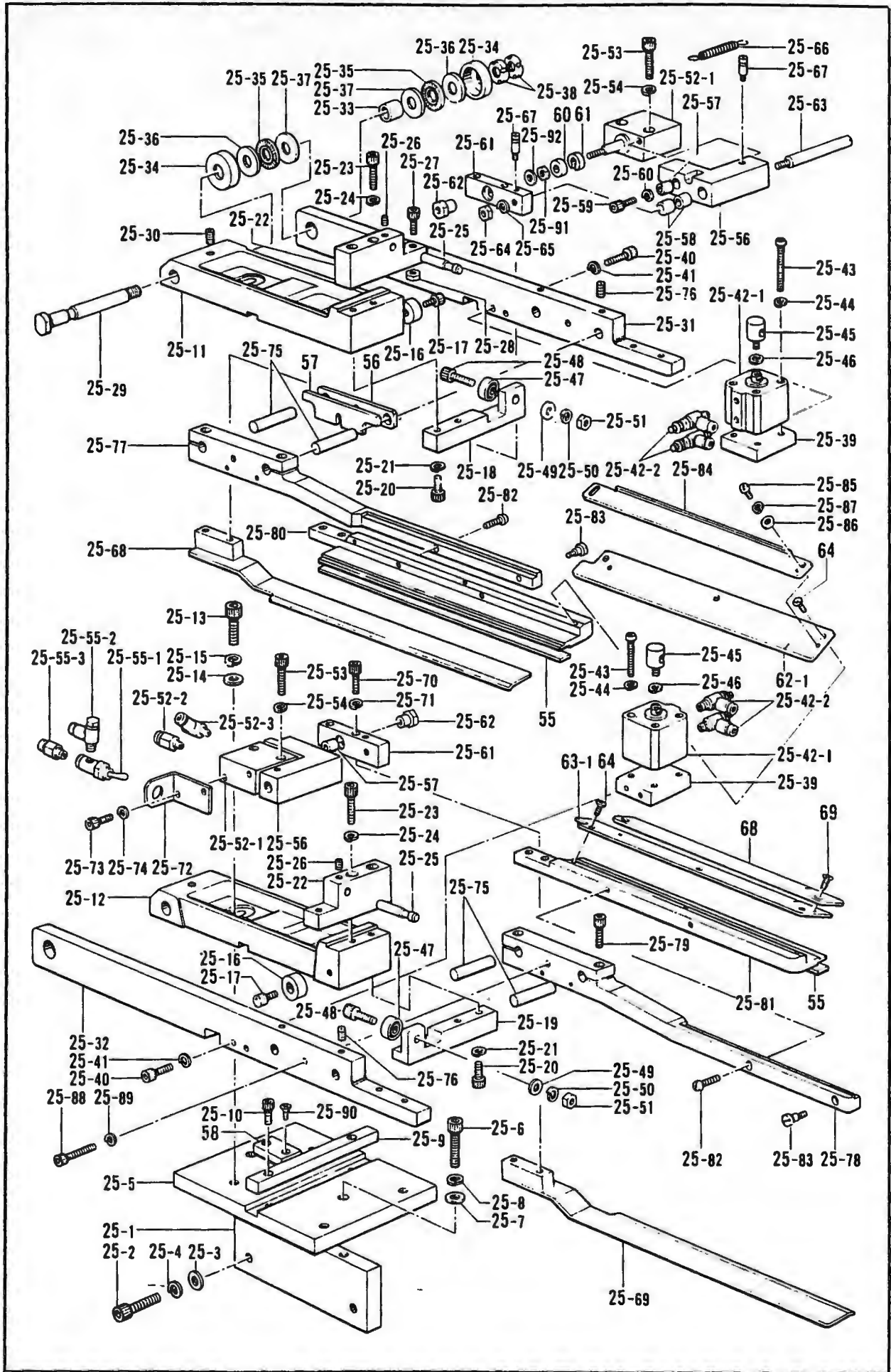

R. 布制御関係/Cloth control system mechanism/Stoffführungsvorrichtung/
 Mécanisme de la système de contrôle du tissu/Mecanismo de la sistema de control de tela

REF.NO	CODE	Q'TY	品名	NAME OF PARTS	RMKS
25-55	S08493000	2	キリカエバルブクミ	SELECTOR VALVE ASSEMBLY	
25-55-1	S08489000	2	シユト"ウハ"ルブ	HAND VALVE	
25-55-2	S06883000	2	Sエルボ"M5-4	S-ELBOW M5-4	
25-55-3	S06882000	2	ツキ"チM5-4	JOINT M5-4	
25-56	S08253000	2	ガイド"シ"クブラケット	GUIDE SHAFT BRACKET	
25-57	S08507000	2	ト"ライハ"アリンク	BUSH BM0608FB	
25-58	S08397000	4	ト"ライハ"アリンク	BUSH BM0808FB	
25-59	018401222	4	アナボ"ルト4X12	BOLT 4X12	
25-60	028040242	4	ハ"ネサ"ガ"ネ2-4	SPRING WASHER 2-4	
25-61	S08207001	2	シリンダ"ーレンケツイタ	CYLINDER CONNECTING PLATE	
25-62	S08149001	2	ナツト	NUT	
25-63	S08256001	2	ガイド"シ"ク	GUIDE SHAFT	
25-64	021060206	2	2シユナツト6	NUT 6	
25-65	028060242	2	ハ"ネサ"ガ"ネ2-6	SPRING WASHER 2-6	
25-66	S08216001	2	ヒツハ"リハ"ネ	SPRING	
25-67	S08509001	4	ハ"ネサ"カ	SPRING HOOK	
25-68	S08254001	1	オリコミイタR	FOLDING PLATE (R)	
25-69	S08255001	1	オリコミイタL	FOLDING PLATE (L)	
25-70	018401622	4	アナボ"ルト4X16	BOLT 4X16	
25-71	028040242	4	ハ"ネサ"ガ"ネ2-4	SPRING WASHER 2-4	
25-72	S08148001	2	バルブ"ササエ	VALVE SUPPORT	
25-73	018400822	4	アナボ"ルト4X8	BOLT 4X8	
25-74	028040242	4	ハ"ネサ"ガ"ネ2-4	SPRING WASHER 2-4	
25-75	S08257001	4	ガイド"シ"ク	GUIDE SHAFT	
25-76	014501222	4	アナトメネシ"5X12ヒラ	SET SCREW 5X12	
25-77	S08258101	1	オオオサエトリツケイタR	CARRIAGE FEED FITTING PLATE (R)	
25-78	S08259101	1	オオオサエトリツケイタL	CARRIAGE FEED FITTING PLATE (L)	
25-79	018501622	4	アナボ"ルト5X16	BOLT 5X16	
25-80	S08260001	1	オオオサエR	CARRIAGE FEED (R)	
25-81	S08261001	1	オオオサエL	CARRIAGE FEED (L)	
25-82	062712012	2	ナヘ"コ476-32X20	SCREW 476X20	
25-83	110233001	2	ダ"ンネシ"4.76	STUD SCREW 4.76	
25-84	S08264001	2	キシ"カ"イト"	CLOTH GUIDE	
25-85	062300416	4	ナヘ"コM3X4	SCREW M3X4	
25-86	025030233	4	ヒラサ"カ"ネチユウ3	PLAIN WASHER 3	
25-87	028030243	4	ハ"ネサ"ガ"ネ2-3	SPRING WASHER 2-3	
25-88	018504032	2	アナボ"ルト 5X40	BOLT 5X40	
25-89	028050242	2	ハ"ネサ"ガ"ネ2-5	SPRING WASHER 2-5	
25-90	004401003	2	+ サラネシ"4X10	SCREW 4X10	
25-91	S13084001	2	ナツト	NUT	
25-92	025050232	2	ヒラサ"カ"ネチユウ5	PLAIN WASHER 5	
55	*	2	オオオサエゴム	CORRIAGE FEED RUBBER	
56	*	2	スヘ"ーサS	SPACER (S)	
57	*	2	スヘ"ーサW	SPACER (W)	
58	*	1	イト"ウタ"イスヘ"ーサ	MOVABLE BASE SPACER	
60	*	2	スヘ"ーサS	SPACER (S)	
61	*	2	スヘ"ーサW	SPACER (W)	
64	004300513	6	+ サラネシ"3X5	SCREW 3X5	
68	*	1	オリコミイタオサエ	FOLDING PLATE PRESSER	
69	*	2	+ サラネシ"3X5	SCREW 3X5	
< 610 >					
62-1	S10659001	1	オオオサエU-SR	CARRIAGE FEED (U-SR)	
63-1	S10660001	1	オオオサエU-SL	CARRIAGE FEED (U-SL)	

R. 布制御関係 / Cloth control system mechanism / Stoffführungsvorrichtung /
 Mécanisme de la système de contrôle du tissu / Mecanismo de la sistema de control de tela

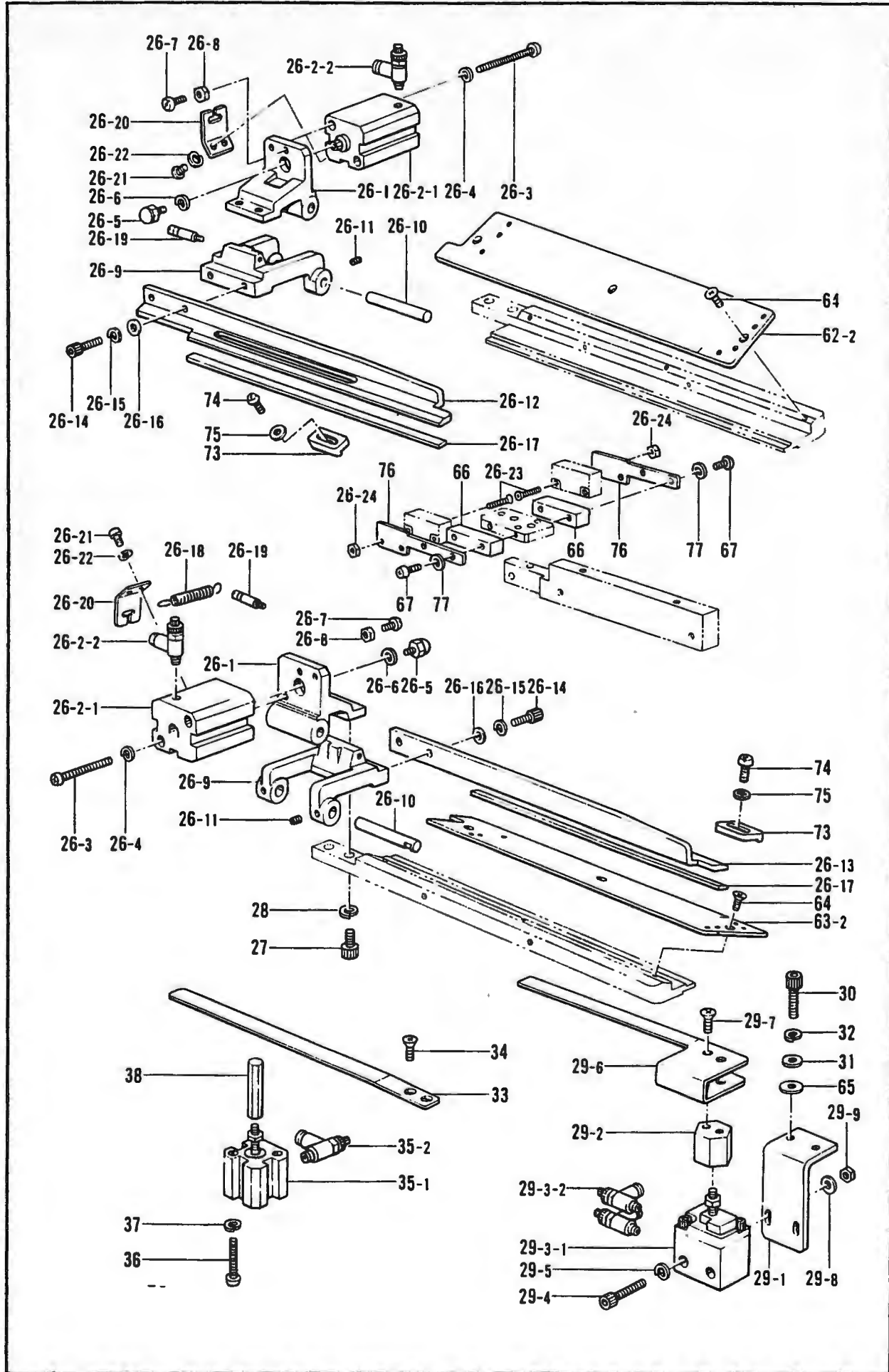

R. 布制御関係/Cloth control system mechanism/Stoffführungsrichtung/
 Mécanisme de la système de contrôle du tissu/Mecanismo de la sistema de control de tela

REF NO	CODE	Q'TY	ヒンメイ	NAME OF PARTS	RMKS
27	018500822	4	アナボルト5X8	BOLT 5X8	
28	028050242	4	ハネサカネ2-5	SPRING WASHER 2-5	
29	S09447009	1	シンジオサイクミ	FUSING PAPER PRESSER FOOT ASSEMBLY	
29-1	S08211001	1	シリンダトリツケイタ	CYLINDER FITTING PLATE	
29-2	S08213001	1	ハネトリツケシク	SPRING FITTING SHAFT	
29-3	S08499000	1	シリンダクミ	CYLINDER ASSEMBLY	
29-3-1	S08243000	1	シリンダ16X10	CYLINDER 16X10	
29-3-2	S08498000	2	スピコンツキチM5-4	SPEED CONTROLLER JOINT M5-4	
29-4	018402522	2	アナボルト4X25	BOLT 4X25	
29-5	028040242	4	ハネサカネ2-4	SPRING WASHER 2-4	
29-6	S08215009	1	シンジオサエハネR	SPRING (R)	
29-7	004300513	2	サラネシ3X5	SCREW 3X5	
29-8	025040232	2	ヒラサカネチユウ4	PLAIN WASHER 4	
29-9	021400202	2	2シユナツト4	NUT 4	
30	018501622	2	アナボルト5X16	BOLT 5X16	
31	025050232	2	ヒラサカネチユウ5	PLAIN WASHER 5	
32	028050242	2	ハネサカネ2-5	SPRING WASHER 2-5	
33	S08214009	1	シンジオサエハネL	SPRING (L)	
34	004401003	2	サラネシ4X10	SCREW 4X10	
35	S09174000	1	シリンダクミ	CYLINDER ASSEMBLY	
35-1	S09175000	1	シリンダ10X5	CYLINDER 10X5	
35-2	S06890000	1	スピコンツキチM5-4	SPEED CONTROLLER JOINT M5-4	
36	062302506	2	ナヘユ3X25	SCREW 3X25	
37	028030243	2	ハネサカネ2-3	SPRING WASHER 2-3	
38	S08208001	1	シンジツシヤ	SHAFT	
65	025060336	2	ヒラサカネチユウ6	PLAIN WASHER 6	

R. 布制御関係 / Cloth control system mechanism / Stoffführungsrichtung /
 Mécanisme de la système de contrôle du tissu / Mecanismo de la sistema de control de tela

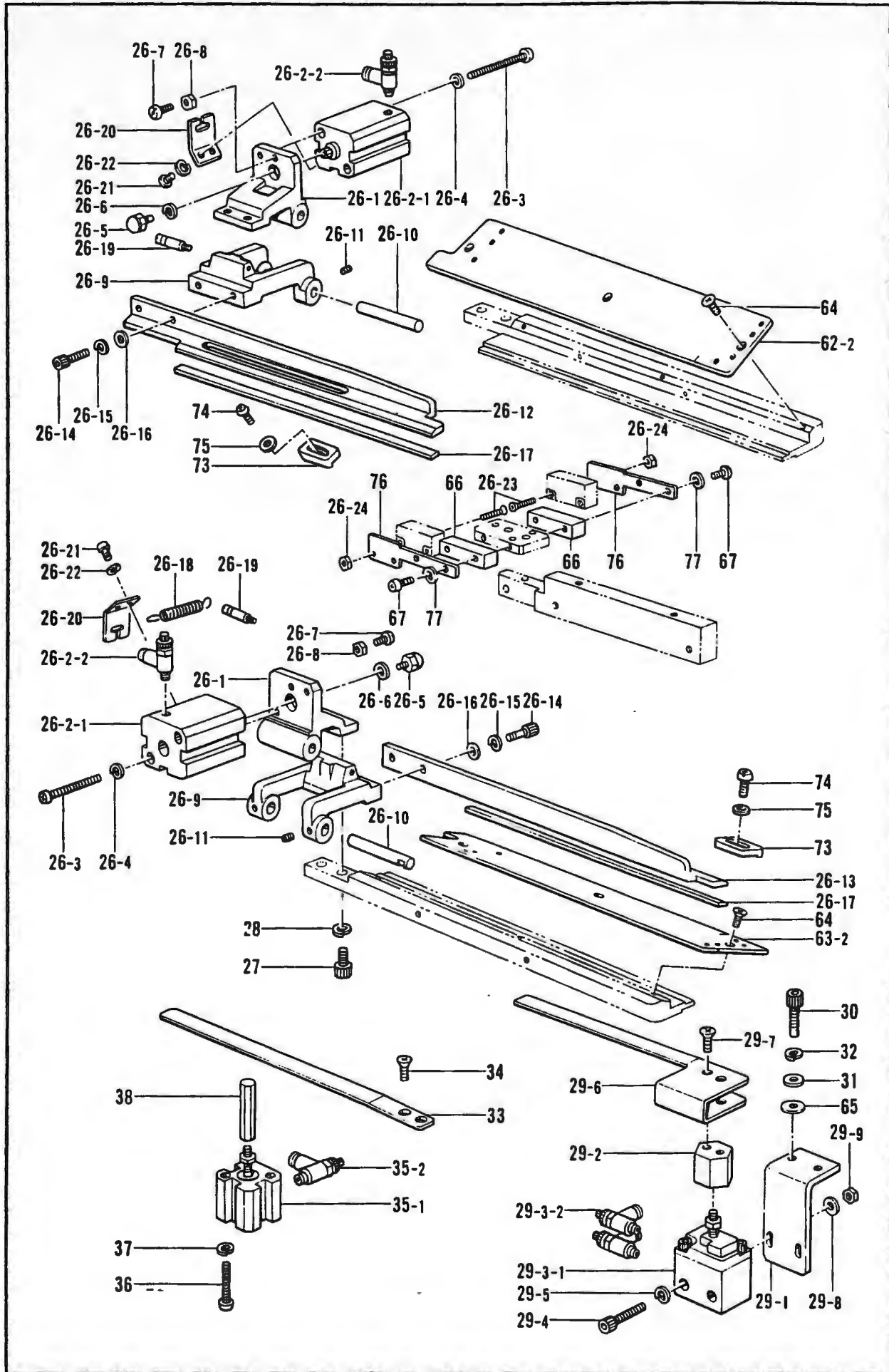

R. 布制御関係 / Cloth control system mechanism / Stoffführungsvorrichtung /
 Mécanisme de la système de contrôle du tissu / Mecanismo de la sistema de control de tela

REF NO	CODE	Q'TY	ヒンメイ	NAME OF PARTS	RMKS
<フラップツケヨウ, FOR FLAP/611 >					
26	S08281001	1	フラップ*オサエクミ	FLAP PRESSER ASSEMBLY	
26-1	S08268001	2	レハ"ターイ	LEVER BRACKET	
26-2	S08271000	2	シリンダ"クミ	CYLINDER ASSEMBLY	
26-2-1	S08272000	2	シリンダ"16X20	CYLINDER 16X20	
26-2-2	S06890000	2	スピ"コンツキ"チM5-4	SPEED CONTROLLER JOINT M5-4	
26-3	S10551001	4	+ナヘ"ネジ"3X55	SCREW 3X55	
26-4	028030243	4	ハ"ネサ"カ"ネ2-3	SPRING WASHER 2-3	
26-5	S08273001	2	フツシヤ	PUSHER	
26-6	028030243	2	ハ"ネサ"カ"ネ2-3	SPRING WASHER 2-3	
26-7	062400812	2	ナヘ"コ4X8	SCREW 4X8	
26-8	021400202	2	2シユナツト4	NUT 4	
26-9	S08275001	2	フラツフ*オサエレハ"ー	FLAP PRESSER LEVER	
26-10	S08276001	2	シテンシ"ク	FULCRUM SHAFT	
26-11	014400522	4	アナクホ"ミ4X5	SET SCREW 4X5	
26-12	S08277001	1	フラツフ*オサエR	FLAP PRESSER (R)	
26-13	S08278001	1	フラツフ*オサエL	FLAP PRESSER (L)	
26-14	018401422	4	アナホ"ルト4X14	BOLT 4X14	
26-15	028040242	4	ハ"ネサ"カ"ネ2-4	SPRING WASHER 2-4	
26-16	025040132	4	ヒラサ"カ"ネシヨウ4	PLAIN WASHER 4	
26-17	S08279000	2	フラツフ*オサエゴム	FLAP PRESSER RUBBER	
26-18	S03557001	2	スライダ"ーヒキハ"ネ	SPRING	
26-19	S08509001	2	ハ"ネカク	SPRING HOOK	
26-20	S09446001	2	ハ"ネカクB	SPRING HOOK (B)	
26-21	062300512	4	ナヘ"コ3X5	SCREW 3X5	
26-22	028030243	4	ハ"ネサ"カ"ネ2-3	SPRING WASHER 2-3	
26-23	S16608001	4	+サラネジ"26X15	SCREW 26X15	
26-24	S16609001	4	2シユナツト26	NUT 26	
62-2	S08262001	1	オオオサエU-R	CARRIAGE FEED (U-R)	
63-2	S08263001	1	オオオサエU-L	CARRIAGE FEED (U-L)	
64	004300513	5	+サラネジ"3X5	SCREW 3X5	
66	*	2	フラツフ*スヘ"ーサ	FLAP SPACER	
67	*	4	ナヘ"コ	SCREW	
73	S08266001	2	フラツフ*ストツハ"	FLAP STOPPER	
74	062300416	2	ナヘ"コM3X4	SCREW M3X4	
75	025030133	2	ヒラサ"カ"ネシヨウ3	PLAIN WASHER 3	
76	S16607001	2	センサタ"イ	SENSOR BASE	
77	028030243	4	ハ"ネサ"カ"ネ2-3	SPRING WASHER 2-3	

S. 針位置検出器関係 / Synchronizer / Synchronisator /
Synchronisateur / Sincronizador

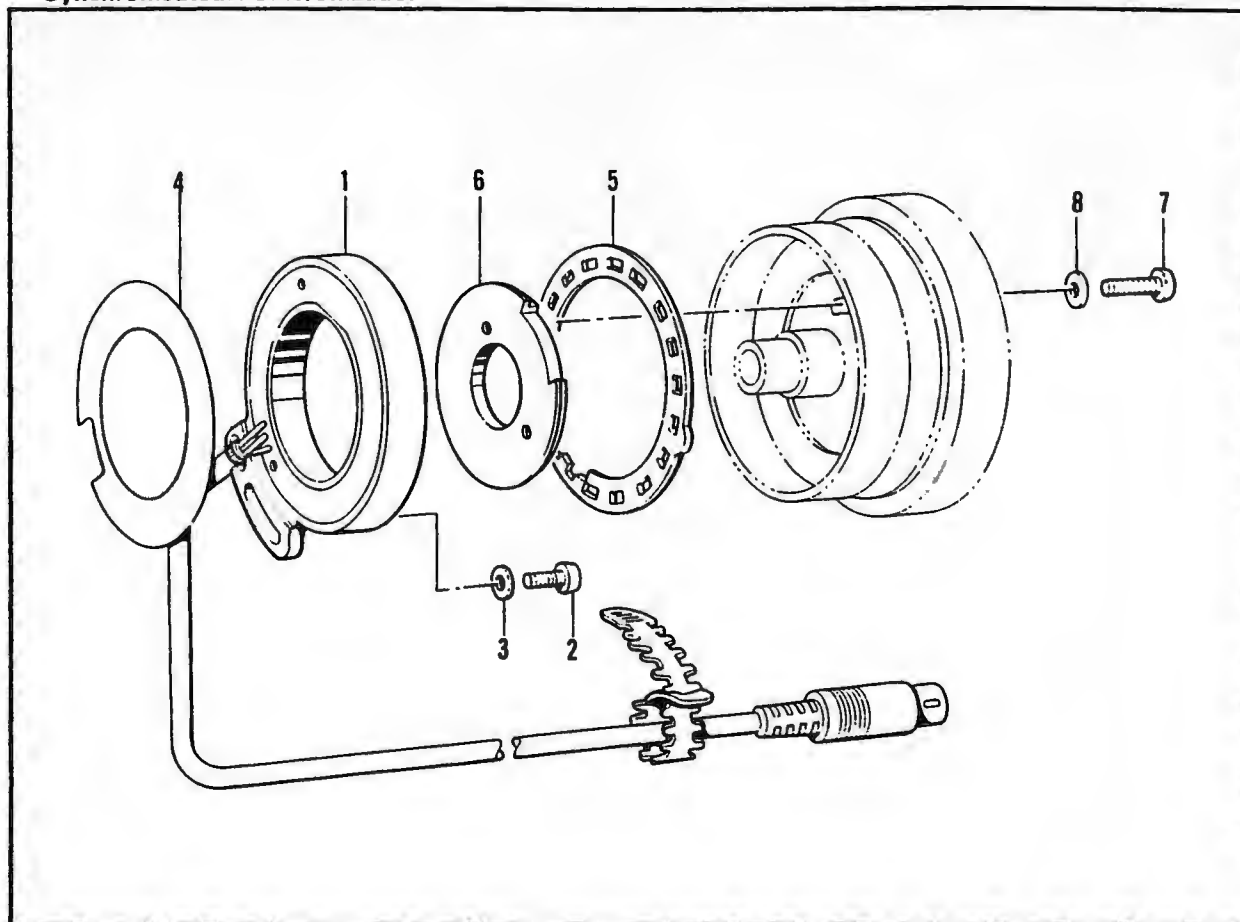

T. ゲージ部品関係 / Gauge mechanism / Lehrenvorrichtung /
Mécanisme de jauge / Mecanismo del galga

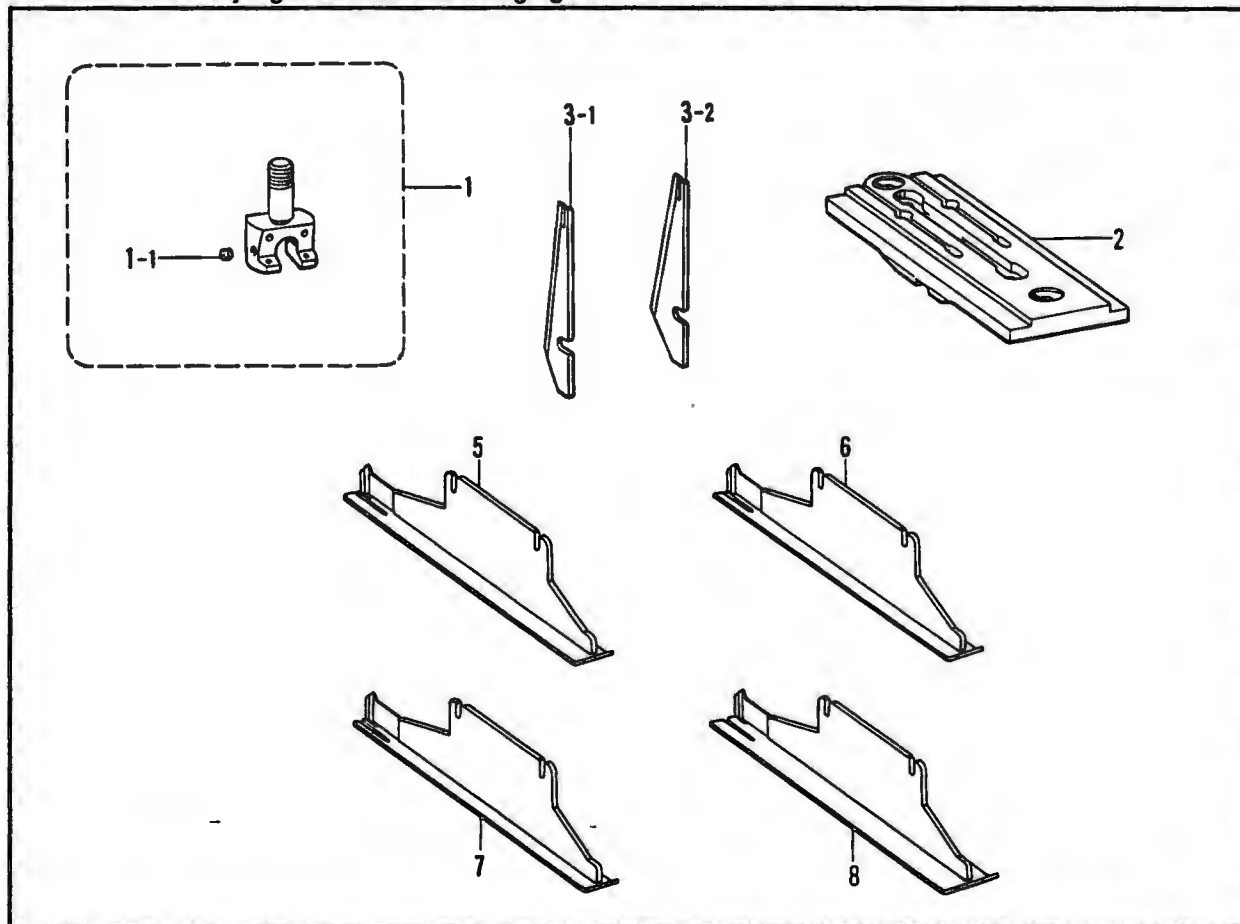

S. 針位置検出器関係/Synchronizer/Synchronisator/
Synchronisateur/Sincronizador

REF.NO	CODE	Q'TY	ヒンメイ	NAME OF PARTS	RMKS
1	237950001	1	シンクロナイザ"クミ#14G2	SYNCHRONIZER ASSEMBLY #14G2	
2	062711012	1	ナヘ"コ476-32X10	SCREW 476X10	
3	113431002	1	サ"ガ"ネ	WASHER	
4	S06241000	1	ゼ"ツエンシート	INSULATION SEAT	
5	S06242001	1	ソクト"シレイタ	SPEED COMMAND PLATE	
6	S14675001	1	ハリウエイタ	NEEDLE UPPER PLATE	
7	062681612	2	ナヘ"コ437-40X16	SCREW 437X16	
8	100645003	2	サ"ガ"ネ	WASHER	

T. ゲージ部品関係/Gauge mechanism/Lehrenvorrichtung/
Mécánisme de jauge/Mecanismo del galga

REF.NO.	CODE	Q'TY	ヒンメイ	NAME OF PARTS	RMKS
1	*	1	ハリタ"キクミ	NEEDLE CLAMP ASSEMBLY	
1-1	146427001	2	アナトメネシ"3.18クホ"ミ	SET SCREW 3.18	
2	*	1	ハリイタ	NEEDLE PLATE	
3-1	S14050001	4	セラミツクコーナーメスS <8-14MM>	CERAMIC CORNER KNIFE (S) <8-14MM>	*
3-2	S14051001	4	セラミツクコーナーメスL <16-20MM>	CERAMIC CORNER KNIFE (L) <16-20MM>	*
5	S15602009	1	OFジ"ヨウキ"クミ 10MM	OFF-SET BINDER ASSEMBLY (10MM)	*
5	S15604009	1	OFジ"ヨウキ"クミ 12MM	OFF-SET BINDER ASSEMBLY (12MM)	*
5	S15606009	1	OFジ"ヨウキ"クミ 14MM	OFF-SET BINDER ASSEMBLY (14MM)	*
6	*	1	Cジ"ヨウキ"クミ	C BINDER ASSEMBLY	
7	*	1	Bジ"ヨウキ"クミ	B BINDER ASSEMBLY	
8	*	1	Dジ"ヨウキ"クミ	D BINDER ASSEMBLY	

U. 踏板関係 / Foot switch pedal mechanism / Fußbetätigung /
Mécánisme de la pédale / Mecanismo del pedal

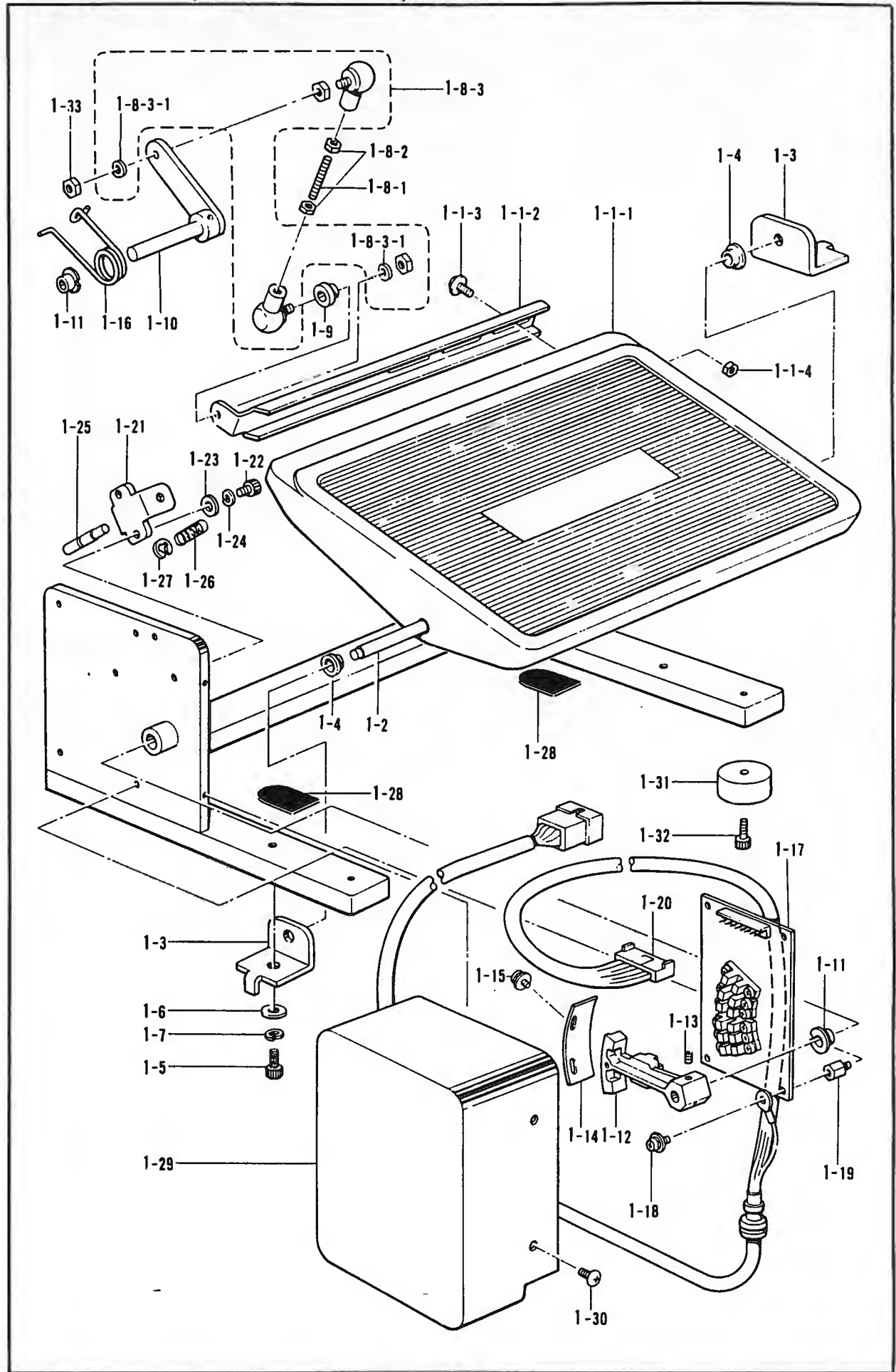

U. 踏板関係/Foot switch pedal mechanism/Fußbetätigung/
Mécansime de la pédale/Mecanismo del pedal

REF.NO.	CODE	Q'TY	ヒンメイ	NAME OF PARTS	RMKS
1	S08409009	1	フットスイッチクミ	FOOT SWITCH ASSEMBLY	
1-1-1	183387009	1	フミイタクミ	TREADLE ASSEMBLY	
1-1-2	119709003	1	レンカントリツケウテ	CONNECTING ROD SET ARM	
1-1-3	S06694001	2	ナヘ"コヒラサ"6X16	WASHER SCREW 6X16	
1-1-4	021060106	2	ナツト1シユ6	NUT 6	
1-2	119706001	1	フミイタジク	TREADLE SHAFT	
1-3	119707003	2	フミイタジクウケ	TREADLE SHAFT BRACKET	
1-4	119708001	2	フミイタジクウケカラー	TREADLE SHAFT BRACKET COLLAR	
1-5	018082022	2	アナホ"ルト8X20	BOLT 8X20	
1-6	025080232	2	ヒラサ"カ"ネチユウ 8	PLAIN WASHER 8	
1-7	028080242	2	ハ"ネサ"カ"ネ2-8	SPRING WASHER 2-8	
1-8	S08411001	1	レンカクミ	CONNECTING ROD ASSEMBLY	
1-8-1	S08412001	1	レンカン	CONNECTING ROD	
1-8-2	021060106	2	ナツト1シユ6	NUT 6	
1-8-3	133792101	2	シ"ヨイントクミ	JOINT ASSEMBLY	
1-8-3-1	028060243	2	ハ"ネサ"カ"ネ2-6	SPRING WASHER 2-6	
1-9	114859001	1	レンカンカラー	CONNECTING ROD COLLAR	
1-10	S08413001	1	フットスイッチレハ"ークミ	FOOT SWITCH LEVER ASSEMBLY	
1-11	S08416000	2	ト"ライヘ"アリング"	BUSH BM0806F15FB	
1-12	S08417000	1	アーム	ARM	
1-13	014400822	2	アナトメネシ"4クホ"ミ	SET SCREW 4	
1-14	S08418000	1	ホトカフ"ラト"ウサイタ	PHOTO COUPLER ACTUATE PLATE	
1-15	052400806	2	ナヘ"コハ"ネヒラ4X8	WASHER SCREW 4X8	
1-16	S08419001	1	フットスイッチハ"ネ	SPRING	
1-17	S08420000	1	キハ"ンクミB439013クミ	CIRCUIT BOARD (B439013) ASSEMBLY	
1-18	052400806	4	ナヘ"コハ"ネヒラ4X8	WASHER SCREW 4X8	
1-19	S08421000	4	スヘ"ーサ	SPACER	
1-20	S08422000	1	FSWハーネスクミ	FOOT SWITCH HARNESS ASSEMBLY	
1-21	S08423001	1	フミカエシジ"クウケ	INDICATION SHAFT SUPPORT	
1-22	018401222	2	アナホ"ルト4X12	BOLT 4X12	
1-23	025040232	2	ヒラサ"カ"ネチユウ4	PLAIN WASHER 4	
1-24	028040242	2	ハ"ネサ"カ"ネ2-4	SPRING WASHER 2-4	
1-25	S08424001	1	フミカエシジ"ク	INDICATION SHAFT	
1-26	147843001	1	ラツクモト"シハ"ネ	SPRING	
1-27	048060342	1	トメフE6	STOP RING E6	
1-28	S14197000	2	クツシヨnC	CUSHION (C)	
1-29	S08426009	1	フットスイッチカハ"ー	FOOT SWITCH COVER	
1-30	008400604	4	+トラスコ4X6	SCREW 4X6	
1-31	S01830000	4	ハ"ネルカハ"ーアシ	PANEL COVER LEG	
1-32	018401622	4	アナホ"ルト4X16	BOLT 4X16	
1-33	021060106	1	ナツト1シユ6	NUT 6	

V. 動力台関係 / Power table / Motorgestell /
 Mécanisme du plateau de la machine / Mecanismo de la mesa de la máquina

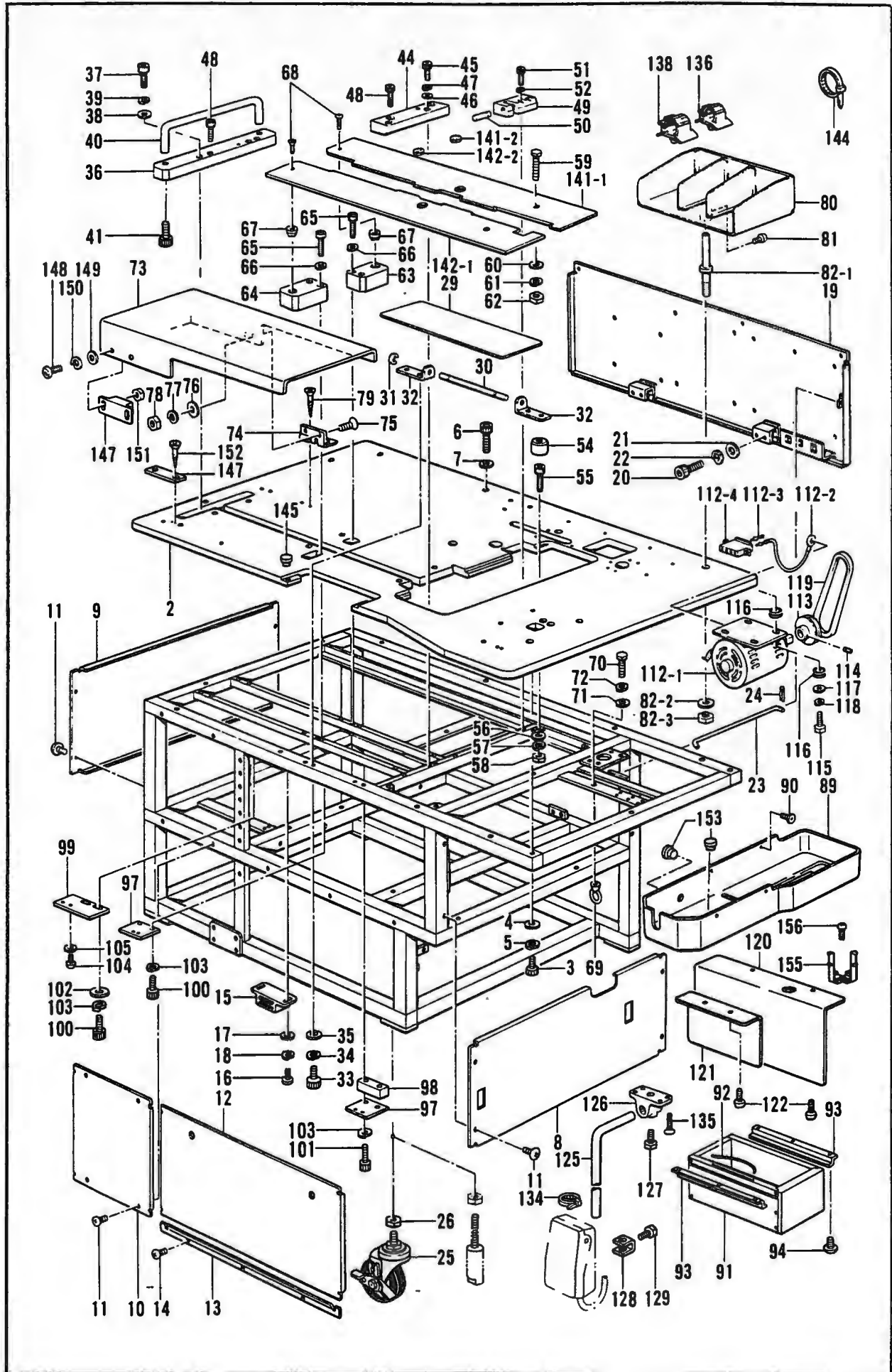

V. 動力台関係/Power table/Motorgestell/
Mécánisme du plateau de la machine/Mecanismo de la mesa de la máquina

REF NO.	CODE	Q'TY	ヒンメイ	NAME OF PARTS	RMKS
2	S14795109	1	BAS610テーブル	BAS-610 TABLE	
3	018501422	7	アナボルト5X14	BOLT 5X14	
4	025050232	7	ヒラサ"ガ"ネチユウ-5	PLAIN WASHER 5	
5	028050242	7	ハ"ネサ"ガ"ネ2-5	SPRING WASHER 2-5	
6	018401622	11	アナボルト4X16	BOLT 4X16	
7	025040232	11	ヒラサ"ガ"ネチユウ4	PLAIN WASHER 4	
8	S15601009	1	マエカハ-	FRONT COVER	
9	S08185009	1	ウシロカハ-	REAR COVER	
10	S08186009	1	ヒタ"リRカハ-	LEFT (R) COVER	
11	008400604	12	+トラスコ4X6	SCREW 4X6	
12	S08187009	1	ヒタ"リFカハ-	LEFT (F) COVER	
13	S08193009	1	カハ-ウケ	COVER SUPPORT	
14	008400604	3	+トラスコ4X6	SCREW 4X6	
15	S09448000	2	マグ"ネット	MAGNET	
16	062300616	4	ナヘ"コM3X6	SCREW M3X6	
17	025030232	4	ヒラサ"ガ"ネチユウ3	PLAIN WASHER 3	
18	028030242	4	ハ"ネサ"ガ"ネ2-3	SPRING WASHER 2-3	
19	S08189009	1	ミキ"カハ-	RIGHT COVER	
20	018501222	4	アナボルト5X12	BOLT 5X12	
21	025050232	4	ヒラサ"ガ"ネチユウ-5	PLAIN WASHER 5	
22	028050242	4	ハ"ネサ"ガ"ネ2-5	SPRING WASHER 2-5	
23	S08191001	1	トヒ"ラステー	DOOR STAY	
24	114909000	1	フリヒ"ン	SPLIT PIN	
25	S00403100	4	キヤスター	CASTER	
26	021200203	4	ナット2シユ20	NUT 20	
29	S08194001	1	ホシ"ヨテ-プ"ル	SUB TABLE	
30	S08368001	1	ホシ"ヨテ-プ"ルヨウシ"ク	SHAFT	
31	048050342	2	トメワE5	STOP RING E5	
32	S08270001	2	ホシ"ヨテ-プ"ルウケ	SUB TABLE SUPPORT	
33	018500822	4	アナボルト5X8	BOLT 5X8	
34	028050242	4	ハ"ネサ"ガ"ネ2-5	SPRING WASHER 2-5	
35	025050232	4	ヒラサ"ガ"ネチユウ-5	PLAIN WASHER 5	
36	S08283001	1	トリツケタ"イウシロ	SET BASE REAR	
37	018062022	2	アナボルト6X20	BOLT 6X20	
38	025060232	2	ヒラサ"ガ"ネチユウ 6	PLAIN WASHER 6	
39	028060242	2	ハ"ネサ"ガ"ネ2-6	SPRING WASHER 2-6	
40	S08190001	1	オオオサエウケ	CARRIAGE FEED SUPPORT	
41	018082022	2	アナボルト8X20	BOLT 8X20	
44	S14796101	1	トリツケタ"イマエ	SET BASE FRONT	
45	018062022	2	アナボルト6X20	BOLT 6X20	
46	025060232	2	ヒラサ"ガ"ネチユウ 6	PLAIN WASHER 6	
47	028060242	2	ハ"ネサ"ガ"ネ2-6	SPRING WASHER 2-6	
48	018082522	4	アナボルト8X25	BOLT 8X25	
49	S14797001	2	ヒンシ"ウケ	HINGE SUPPORT	
50	S14798001	2	ローレットヒ"ン	PIN	
51	018401622	4	アナボルト4X16	BOLT 4X16.	
52	028040242	4	ハ"ネサ"ガ"ネ2-4	SPRING WASHER 2-4	
54	S08205000	4	クツシヨ"ン	CUSHION	
55	018061622	4	アナボルト6X16	BOLT 6X16	
56	025060232	4	ヒラサ"ガ"ネチユウ 6	PLAIN WASHER 6	
57	028060242	4	ハ"ネサ"ガ"ネ2-6	SPRING WASHER 2-6	
58	021060102	4	ナット1シユ6	NUT 6	
59	S08200001	2	イチキメボ"ルト	POSITIONING BOLT	
60	025060232	2	ヒラサ"ガ"ネチユウ 6	PLAIN WASHER 6	
61	028060242	2	ハ"ネサ"ガ"ネ2-6	SPRING WASHER 2-6	
62	021060102	2	ナット1シユ6	NUT 6	
63	S09449001	1	シデンヒ"ンアンナイR	PIN GUIDE (R)	
64	S08201001	1	シデンヒ"ンアンナイL	PIN GUIDE (L)	
65	018401622	4	アナボルト4X16	BOLT 4X16	
66	028040242	4	ハ"ネサ"ガ"ネ2-4	SPRING WASHER 2-4	
67	S08197001	2	シデンヒ"ン	PIN	
68	004300602	2	+ サラネシ"3X6	SCREW 3X6	

V. 動力台関係/Power table/Motorgestell/
 Mécanisme du plateau de la machine/Mecanismo de la mesa de la máquina

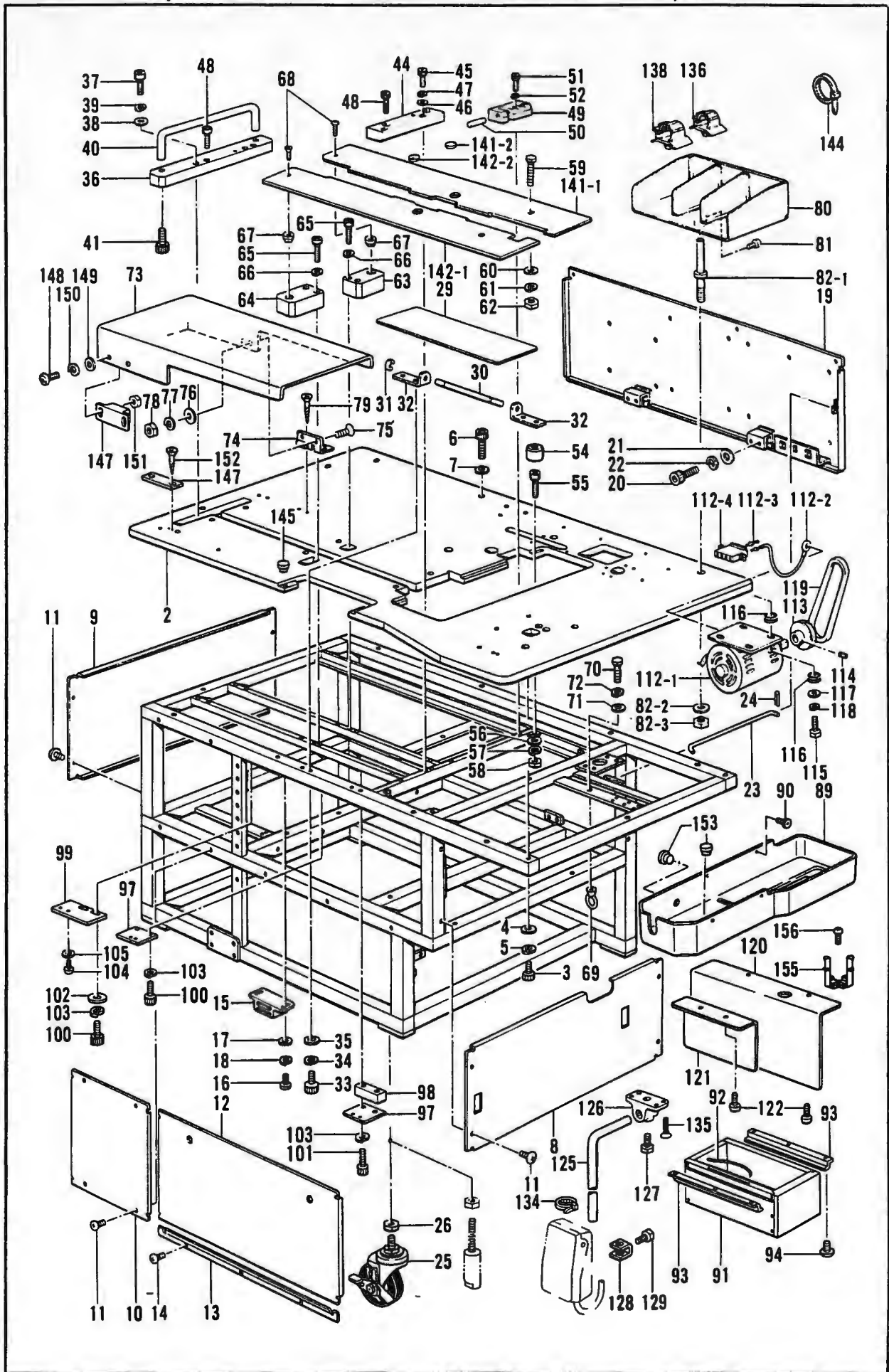

V. 動力台関係/Power table/Motorgestell/
Mécanisme du plateau de la machine/Mecanismo de la mesa de la máquina

REF NO	CODE	Q'TY	ヒンメイ	NAME OF PARTS	RMKS
69	S07026001	1	エアガンフック	AIR GUN HOOK	
70	017082203	1	ボルト8X22	BOLT 8X22	
71	025080232	1	ヒラサ"カ"ネチユウ 8	PLAIN WASHER 8	
72	028080242	1	ハ"ネサ"カ"ネ2-8	SPRING WASHER 2-8	
73	S08206009	1	トップカバー	TOP COVER	
74	S09690001	2	チヨウハン	HINGE	
75	004301003	4	+ サラネシ"3X10	SCREW 3X10	
76	025030232	4	ヒラサ"カ"ネチユウ3	PLAIN WASHER 3	
77	028030242	4	ハ"ネサ"カ"ネ2-3	SPRING WASHER 2-3	
78	021300103	4	ナット1シユ3	NUT 3	
79	034311302	4	+ サラモクネシ"3.1X13	SCREW 3.1X13	
80	S08221009	1	ヌノウケサラ	CLOTH SUPPORT DISC	
81	062060806	2	ナヘ"コ6X8	SCREW 6X8	
82	S10559009	1	ヌノウケサラシチユウクミ	DISC STUD ASSEMBLY	
82-1	S08222009	1	ヌノウケサラシチユウ	DISC STUD	
82-2	150206002	1	ヒラサ"カ"ネ16	PLAIN WASHER 16	
82-3	150191001	1	ロツカクナットU5/8	NUT 5/8	
89	S15673001	1	オイルパン	OIL PAN	
90	008300604	4	+トラスコ3X6	SCREW 3X6	
91	S08192009	1	ヒキタ"シ	DRAWER	
92	101073001	1	ヒキタ"シコテイハ"ネ	SPRING	
93	S08427001	2	ヒキタ"シサエ	DRAWER SUPPORT	
94	008300604	4	+トラスコ3X6	SCREW 3X6	
97	S08224001	2	センサートリツクダイ	SENSOR SET BASE	
98	S08225001	1	スヘ"ウ	SPACER	
99	S09450001	1	センサートリツクダイL	SENSOR SET BASE (L)	
100	018401222	4	アナボルト4X12	BOLT 4X12	
101	018402522	2	アナボルト4X25	BOLT 4X25	
102	025040232	6	ヒラサ"カ"ネチユウ4	PLAIN WASHER 4	
103	028040242	6	ハ"ネサ"カ"ネ2-4	SPRING WASHER 2-4	
104	002301203	6	+ナヘ"ネシ"3X12	SCREW 3X12	
105	025030233	6	ヒラサ"カ"ネチユウ3	PLAIN WASHER 3	
112	S08089001	1	3ソウモータ200Vクミ	3-PHASE MOTOR 200V ASSEMBLY	
112-1	159812001	1	モータ	MOTOR	
112-2	S00614000	1	モータアースセン	MOTOR EARTH WIRE	
112-3	S03328000	3	ピンターミナルオスL	TERMINAL PIN (L)(MALE)	
112-4	S00603000	1	コネクタ4P	4P CONNECTOR	
113	159386001	1	モータプーリー3200/60	MOTOR PULLEY 3200/60 (14MM)	
114	014760622	2	アタメネシ"5.95	SET SCREW 5.95	
115	017062503	4	6カクボルト6X25	BOLT 6X25	
116	S00617000	8	ホ"ウシシゴムカラー	RUBBER COLLAR	
117	025060336	4	ヒラサ"カ"ネチユウ6	PLAIN WASHER 6	
118	028060242	4	ハ"ネサ"カ"ネ2-6	SPRING WASHER 2-6	
119	S18707041	1	VベルトMシロ (M41)	V BELT M WHITE (M41)	
120	S15067001	1	ベルトカバーR	BELT COVER (R)	
121	S16255001	1	モーターカバー	MOTOR COVER	
122	008400604	4	+トラスコ4X6	SCREW 4X6	
125	S08220001	1	ヒザ"スイツチタテシ"ク	KNEE SWITCH VERTICAL SHAFT	
126	142027001	1	ヒザ"スイツチタテシ"クウケ	KNEE SWITCH SHAFT BRACKET	
127	100463001	1	4カクボルト7.94	BOLT 7.94	
128	114967001	1	ヒザ"アテストツパ"	KNEE LIFTER PLATE STOPPER	
129	110087001	1	ボルト5.95	BOLT 5.95	
134	S04557000	1	バンドPTIM	BAND PLTIM	
135	004401003	4	+サラネシ"4X10	SCREW 4X10	
136	150349001	4	コードクランプ"10	CORD CLAMP #10	
138	S09142000	10	コードクランプ"20L	CORD CLAMP #20L	
141	*	1	キジ"スヘ"リイタRクミ	SLIDE PLATE (R) ASSEMBLY	
141-1	*	1	キジ"スヘ"リイタR	SLIDE PLATE (R)	
141-2	S07320000	1	スヘ"リイタマト"	BOBBIN WINDOW	
142	*	1	キジ"スヘ"リイタLクミ	SLIDE PLATE (L) ASSEMBLY	
142-1	*	1	キジ"スヘ"リイタL	SLIDE PLATE (L)	
142-2	S07320000	1	スヘ"リイタマト"	BOBBIN WINDOW	

V. 動力台関係 / Power table / Motorgestell /
 Mécanisme du plateau de la machine / Mecanismo de la mesa de la máquina

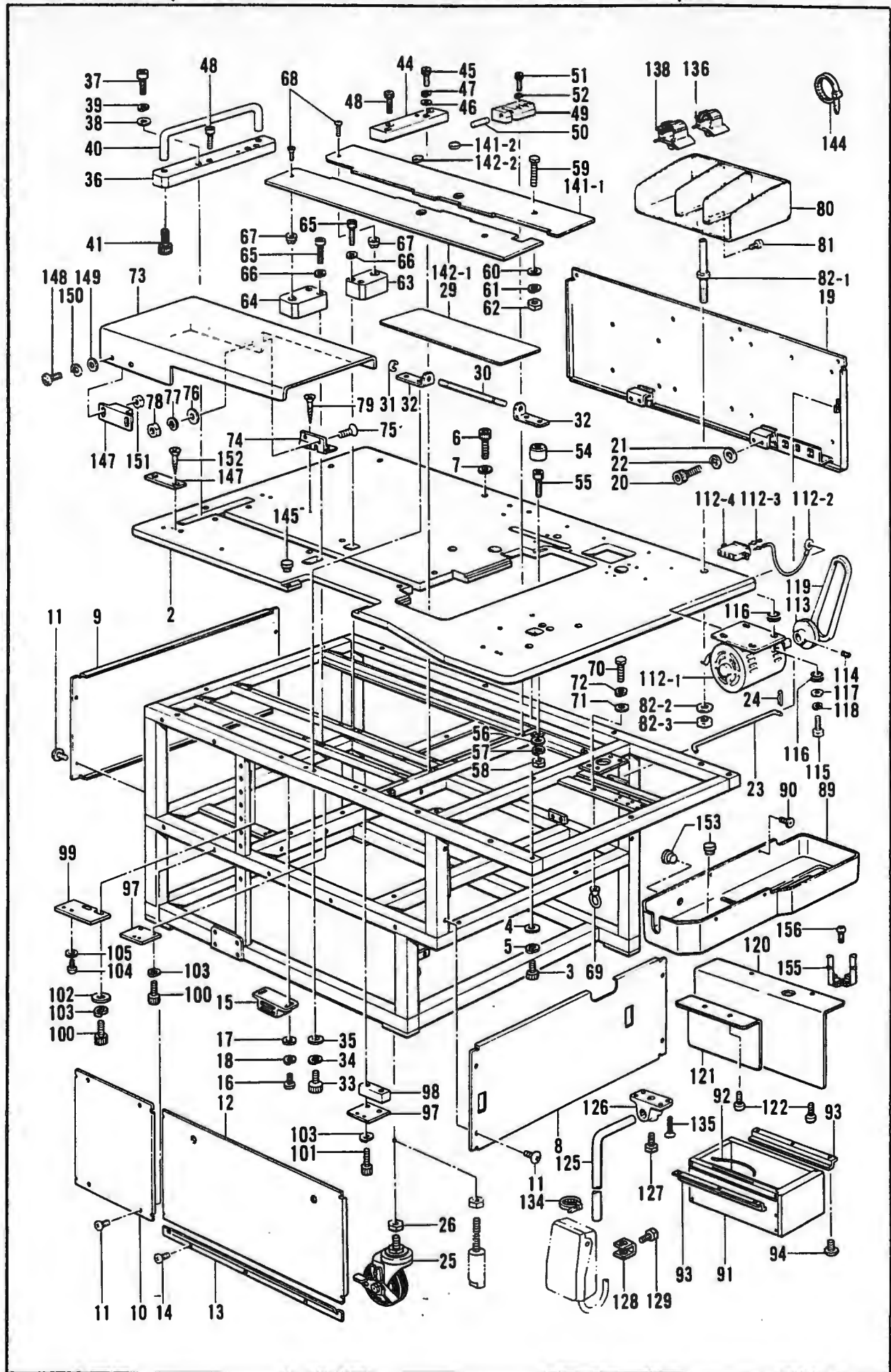

V. 動力台関係/Power table/Motorgestell/
 Mécanisme du plateau de la machine/Mecanismo de la mesa de la máquina

REF NO.	CODE	Q'TY	ヒンメイ	NAME OF PARTS	RMKS
144	149809000	1	タイラツプL	BEAD BAND (L)	
145	104821009	4	メクラセン	OIL CAP	
147	S09448000	1	マグネット	MAGNET	
148	062300806	2	ナヘ"COM3X8	SCREW 3X8	
149	025030233	2	ヒラサ"ガ"ネチユウ3	PLAIN WASHER 3	
150	028030243	2	ハ"ネサ"ガ"ネ2-3	SPRING WASHER 2-3	
151	021300103	2	ナツト1シユ3	NUT 3	
152	034311302	2	+サラモクネシ"3.1X13	SCREW 3.1X13	
153	150756009	2	メクラセン	OIL CAP	
155	133172003	1	アブ"ラサシダ"イ	OIL BRACKET	
156	008400604	1	+トラスコ4X6	SCREW 4X6	

W1. 特別注文部品 / Option parts / Sonderzubehör /
Pièces en option / Piezas opcionales

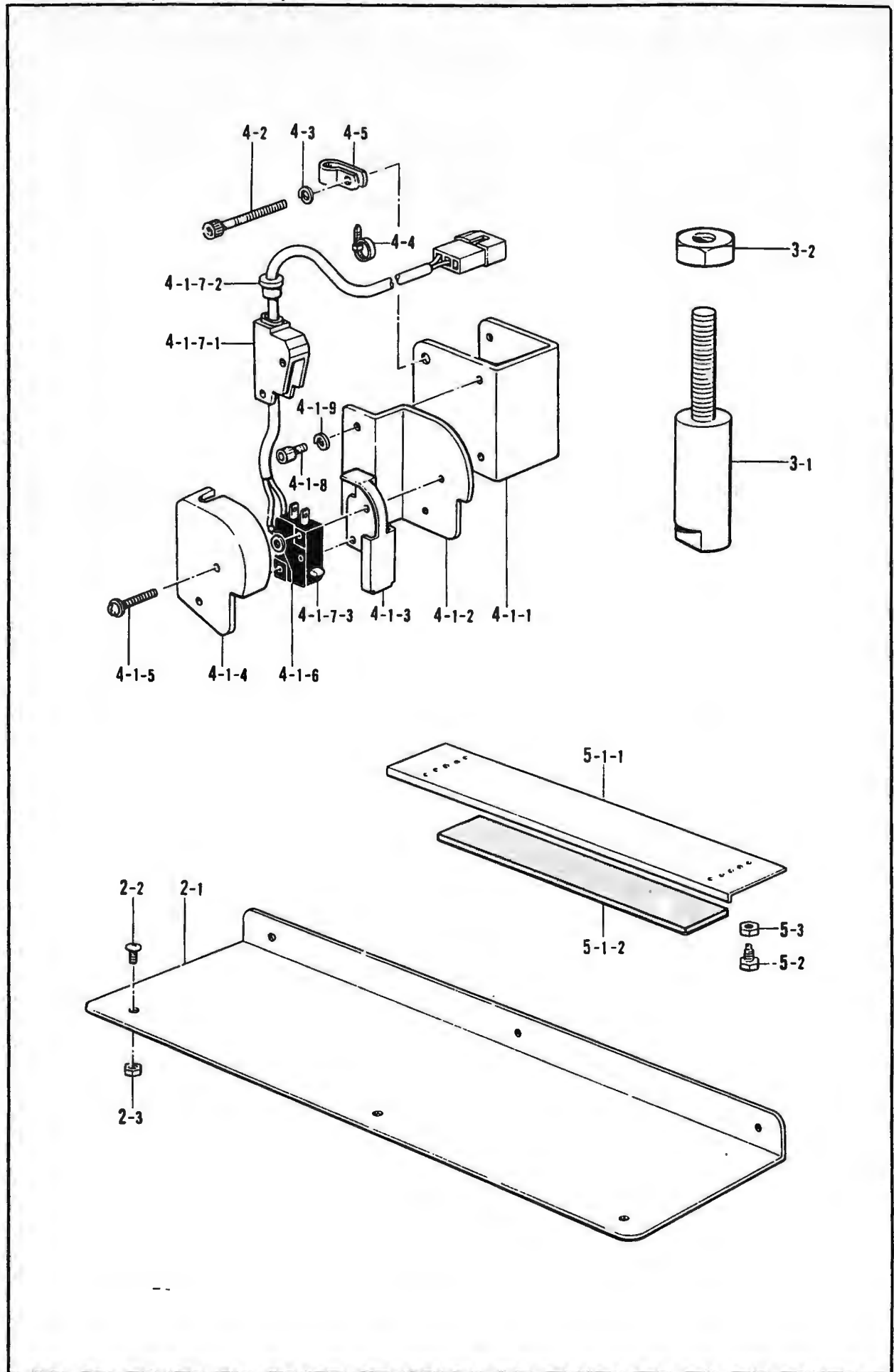

W1. 特別注文部品/Option parts/Sonderzubehör/
Pièces en option/Piezas opcionales

REF NO	CODE	Q'TY	品名	NAME OF PARTS	RMKS
2	S11502009	1	ホシヨクイクミ	AUXILIARY BASE ASSEMBLY	
2-1	S09687009	1	ホシヨクイ	AUXILIARYBASE	
2-2	008400604	3	トラスコ4X6	SCREW 4X6	
2-3	021400103	3	ナット1シユ4	NUT 4	
3	S11148001	4	チヨウセツネシクミ	ADJUST SCREW ASSEMBLY	
3-1	S00402001	4	チヨウセツネシ	ADJUST SCREW	
3-2	021200203	4	ナット2シユ20	NUT 20	
4	S11503009	1	テモスタートスイッチクミ	HAND START SWITCH ASSEMBLY	
4-1	S11334001	1	テモスイッチクミ	HAND SWITCH ASSEMBLY	
4-1-1	S11335009	1	スタートスイッチダクイ	START SWITCH BRACKET	
4-1-2	S04607009	1	スイッチトリツケイタ	SWITCH SET PLATE	
4-1-3	149069101	1	アクチュエータ	ACTUATOR	
4-1-4	149070009	1	スイッチカバー	SWITCH COVER	
4-1-5	522990001	2	サツキシメネシ3X19	SCREW 3X19	
4-1-6	025030233	2	ヒラサカネチユウ3	PLAIN WASHER 3	
4-1-7	S11336009	1	スイッチクミ	SWITCH ASSEMBLY	
4-1-7-1	143531000	1	マイクロSWカバー	MICRO SWITCH COVER	
4-1-7-2	146080009	1	コードブッシュ	CORD BUSH	
4-1-7-3	149066001	1	マイクロスイッチ	MICRO SWITCH	
4-1-8	018400622	2	アナボルト4X6	BOLT 4X6	
4-1-9	028040242	2	ハネサカネ2-4	SPRING WASHER 2-4	
4-2	155055001	2	アナボルト4X45	BOLT 4X45	
4-3	028040242	2	ハネサカネ2-4	SPRING WASHER 2-4	
4-4	S04557000	2	バンドPLTIM	BAND PLTIM	
4-5	149547000	1	コードホルダ	CORD HOLDER (4N)	
5	S11504001	1	フラップガイドクミ	FLAP GUIDE ASSEMBLY	
5-1	S11505000	1	フラップガイド	FLAP GUIDE	
5-1-1	S11083000	1	ガイドプレート	GUIDE PLATE	
5-1-2	S11506000	1	ゴム磁石	RUBBER MAGNET	
5-2	S11084001	2	フラップガイドピン	PIN	
5-3	021400103	2	ナット1シユ4	NUT 4	

W2. 特別注文部品 (ダーツノバシ)/Option parts (Darts stretcher)/Sonderzubehör (Abnäherstrecker)/
Pièces en option (tendeur pour pince)/Piezas opcionales (estirador de sisa)

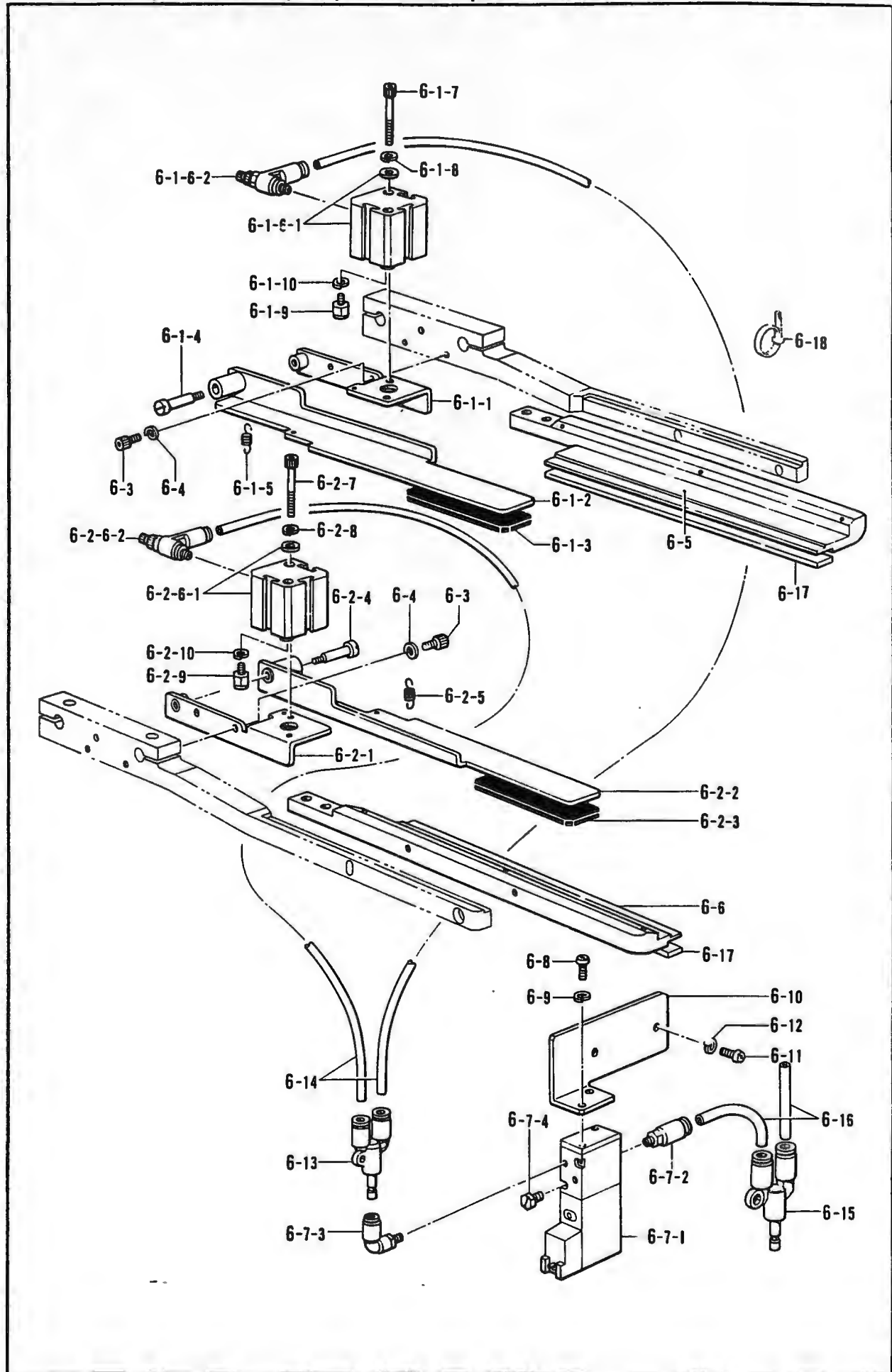

W2. 特別注文部品 (ダーツノバシ)/Option parts (Darts stretcher)/Sonderzubehör (Abnäherstrecker)/
Pièces en option (tendeur pour pince)/Piezas opcionales (estirador de sisa)

REF NO	CODE	Q'TY	ヒンメイ	NAME OF PARTS	RMKS
6	S15890001	1	ダーツノバシシクニ610	DARTS STRETCHER ASSEMBLY	
6-1	S15891001	1	ダーツオサERクミ	DARTS PRESSER (R) ASSEMBLY	
6-1-1	S13570001	1	Dフ"ラケツトR	DARTS BRACKET (R)	
6-1-2	S13572001	1	ダーツオサER	DARTS PRESSER (R)	
6-1-3	S13576100	1	ダーツオサエゴム	DARTS PRESSER RUBBER	
6-1-4	159732001	1	タ"ンネジ"4.37	STUD SCREW 4.37	
6-1-5	S10268001	1	イトマキウテ"ハ"ネ	SPRING	
6-1-6	S13574000	1	シリンダ"クミ	CYLINDER ASSEMBLY	
6-1-6-1	S13575000	1	シリンダ"16X10	CYLINDER 16X10	
6-1-6-2	S06890000	1	スピ"コンツキ"テム5-4	SPEED CONTROLLER JOINT M5-4	
6-1-7	S12642001	2	アナホ"ルト3X35	BOLT 3X35	
6-1-8	028030243	2	ハ"ネサ"カ"ネ2-3	SPRING WASHER 2-3	
6-1-9	S04411001	1	Bクランプ"ヘッド"	(B) CLAMP HEAD	
6-1-10	028030243	1	ハ"ネサ"カ"ネ2-3	SPRING WASHER 2-3	
6-2	S15892001	1	ダーツオサELクミ	DARTS PRESSER (L) ASSEMBLY	
6-2-1	S13571001	1	Dフ"ラケツトL	DARTS BRACKET (L)	
6-2-2	S13573001	1	ダーツオサEL	DARTS PRESSER (L)	
6-2-3	S13576100	1	ダーツオサエゴム	DARTS PRESSER RUBBER	
6-2-4	159732001	1	タ"ンネジ"4.37	STUD SCREW 4.37	
6-2-5	S10268001	1	イトマキウテ"ハ"ネ	SPRING	
6-2-6	S13574000	1	シリンダ"クミ	CYLINDER ASSEMBLY	
6-2-6-1	S13575000	1	シリンダ"16X10	CYLINDER 16X10	
6-2-6-2	S06890000	1	スピ"コンツキ"テム5-4	SPEED CONTROLLER JOINT M5-4	
6-2-7	S12642001	2	アナホ"ルト3X35	BOLT 3X35	
6-2-8	028030243	2	ハ"ネサ"カ"ネ2-3	SPRING WASHER 2-3	
6-2-9	S04411001	1	Bクランプ"ヘッド"	(B) CLAMP HEAD	
6-2-10	028030243	1	ハ"ネサ"カ"ネ2-3	SPRING WASHER 2-3	
6-3	018400822	4	アナホ"ルト4X8	BOLT 4X8	
6-4	028040242	4	ハ"ネサ"カ"ネ2-4	SPRING WASHER 2-4	
6-5	S14063001	1	オオオサER-DTS	BIG PRESSER (R-DTS)	
6-6	S14062001	1	オオオサEL-DTS	BIG PRESSER (L-DTS)	
6-7	S13577000	1	ハ"ルフ"ユニットDTS	VALVE UNIT (DTS)	
6-7-1	S13578000	1	ハ"ルフ"VZ3120	VALVE VZ3120	
6-7-2	S14145000	1	ハーフユニオン06-M5	HALF UNION 06-M5	
6-7-3	S11426000	1	エルボ"ユニオン4M5	ELBOW UNION 4M5	
6-7-4	156096000	1	M5フ"ラク"	M5 PLUG	
6-8	002301003	2	ナヘ"コネジ"3X10	SCREW 3X10	
6-9	028030243	2	ハ"ネサ"カ"ネ2-3	SPRING WASHER 2-3	
6-10	S13579001	1	ハ"ルフ"フ"ラケツト	VALVE BRACKET	
6-11	062500812	2	ナヘ"コ5X8	SCREW 5X8	
6-12	028050242	2	ハ"ネサ"カ"ネ2-5	SPRING WASHER 2-5	
6-13	S08178000	1	ブ"ランチUY-4	BRANCH UY-4	
6-14	S08172000	2	エア"ホース4-K	AIR TUBE 4-K	
6-15	S14146000	1	ブ"ランチUY-6	BRANCH UY-6	
6-16	S08146000	2	エア"ホース6-A	AIR TUBE 6-A	
6-17	S08267003	2	オオオサエゴム	CARRIAGE FEED RUBBER	
6-18	S04557000	7	ハ"ンタイPLTIM	BAND PLTIM	

**W3. 特別注文部品 (エアージェクター)/Option parts (Air ejector)/Sonderzubehör (Luftausstosser)/
Pièces en option (éjecteur d'air)/Piezas opcionales (eyector de aire)**

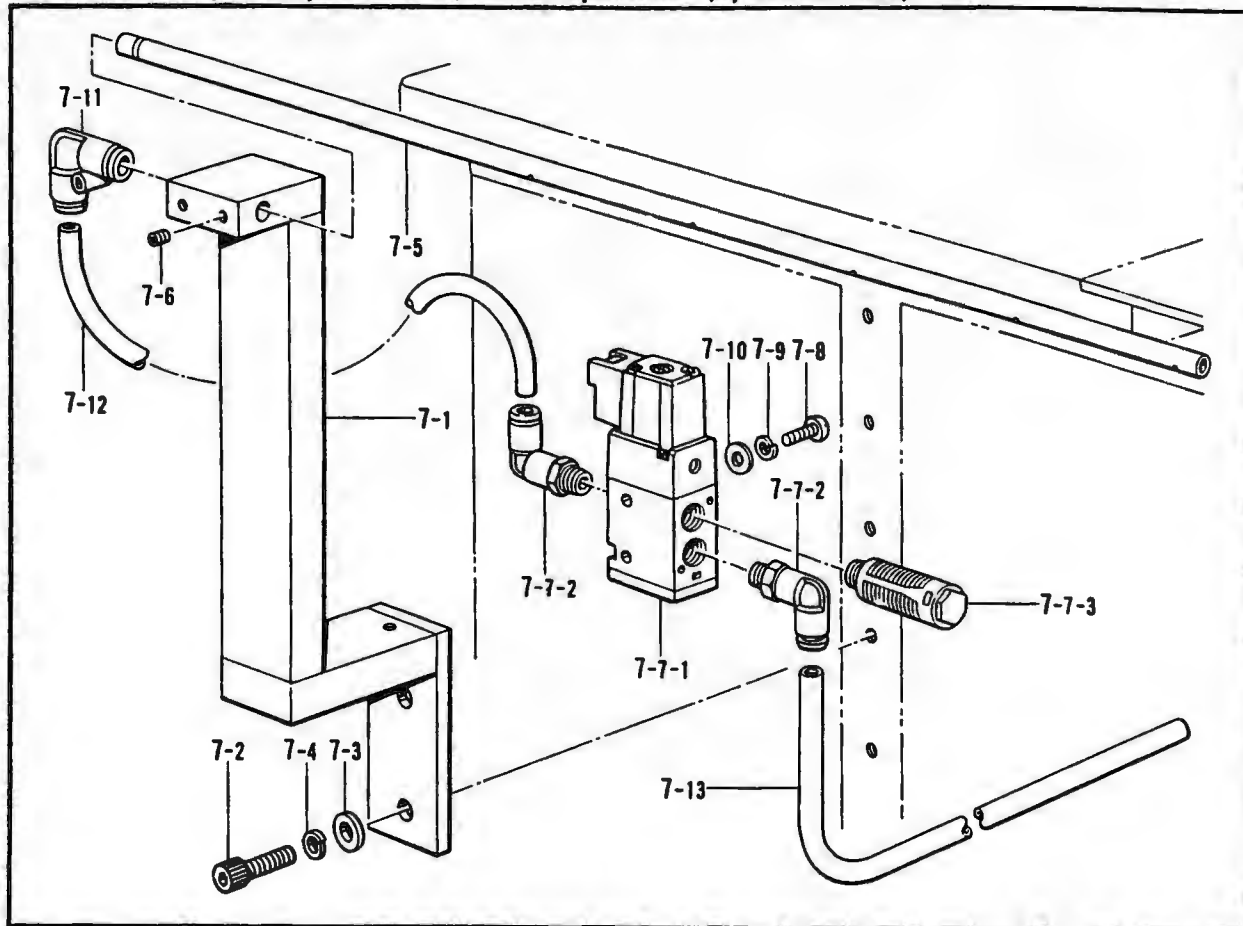

**W4. 特別注文部品(下送り装置)/Option parts (Bottom feed set)/Sonderzubehör (Untertransportsatz)/
Pièces en option (Jeu d'entraînement inférieur)/Piezas opcionales (Juego de alimentación inferior)**

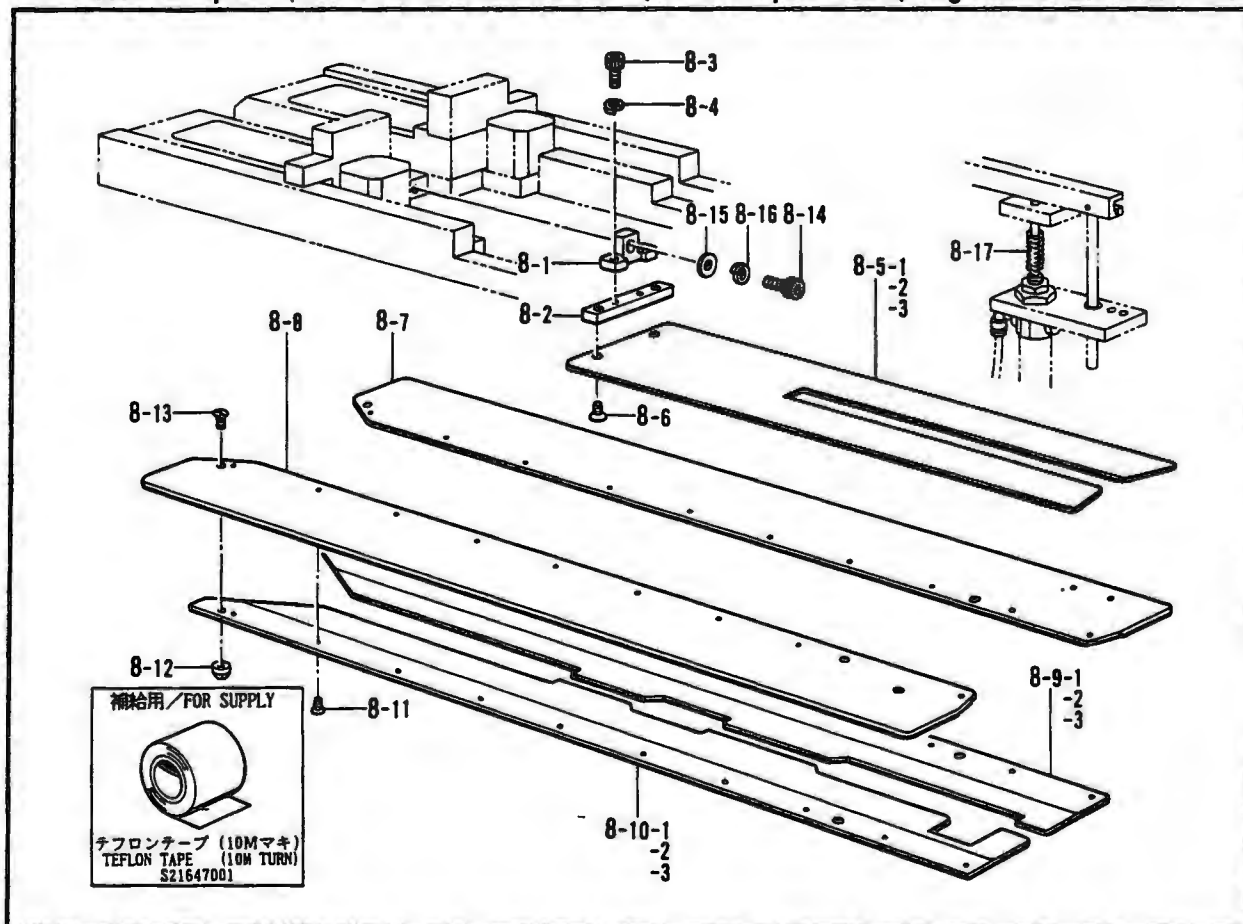

W3. 特別注文部品 (エアージェクター)/Option parts (Air ejector)/Sonderzubehör (Luftausstosser)/
Pièces en option (éjecteur d'air)/Piezas opcionales (eyector de aire)

REF NO.	CODE	Q'TY	ヒンメイ	NAME OF PARTS	RMKS
7	S14155009	1	エアジ"エクター"クミ	AIR EJECTOR ASSEMBLY	
7-1	S14156009	1	イシ"エクター"クミ	EJECTOR BRACKET	
7-2	018082022	2	アナボ"ルト"8X20	BOLT 8X20	
7-3	025080232	2	ヒラサ"カ"ネチユウ B	PLAIN WASHER 8	
7-4	028080242	2	ハ"ネサ"カ"ネ2-8	SPRING WASHER 2-8	
7-5	S14091001	1	スタツカー"エアノズル"	STACKER AIR NOZZLE	
7-6	014500522	2	アトメネジ"5クホ"ミ	SET SCREW 5	
7-7	S14157001	1	ハ"ルブ"ユニツトSAE	VALVE UNIT SAE	
7-7-1	S14158000	1	ハ"ルブ"VZ512	VALVE VZ512	
7-7-2	S14159000	2	エルボ"1/8-8	ELBOW 1/8-8	
7-7-3	140682001	1	サイレンサー	SILENCER	
7-8	062302505	2	ナヘ"ユ3X25	SCREW 3X25	
7-9	028030243	2	ハ"ネサ"カ"ネ2-3	SPRING WASHER 2-3	
7-10	025030233	2	ヒラサ"カ"ネチユウ3	PLAIN WASHER 3	
7-11	S14160000	1	エルボ"	ELBOW	
7-12	S14161000	1	エア"ホ"ス8-C	AIR TUBE 8-C	
7-13	S08361000	1	エア"ホ"ス8-B	AIR TUBE 8-B	

W4. 特別注文部品(下送り装置)/Option parts (Bottom feed set)/Sonderzubehör (Untertransportsatz)/
Pièces en option (Jeu d'entraînement inférieur)/Piezas opcionales (Juego de alimentación inferior)

REF.NO.	CODE	Q'TY	ヒンメイ	NAME OF PARTS	RMKS
8	S21616001	1	シタオクリセツト 8-12MM	BOTTOM FEED SET (8-12MM)	
8	S21617001	1	シタオクリセツト14-16MM	BOTTOM FEED SET (14-16MM)	
8	S21618001	1	シタオクリセツト18-20MM	BOTTOM FEED SET (18-20MM)	
8-1	S21619001	1	オクリイタササエ	FEED PLATE SUPPORT	
8-2	S21620001	1	オクリイタク"イ"	FEED PLATE BASE	
8-3	018401022	2	アナボ"ルト"4X10	BOLT 4X10	
8-4	028040242	2	ハ"ネサ"カ"ネ2-4	SPRING WASHER 2-4	
8-5-1	S21623000	1	オクリイタ 8-12MM	FEED PLATE (8-12MM)	
8-5-2	S21624000	1	オクリイタ 14-16MM	FEED PLATE (14-16MM)	
8-5-3	S21625000	1	オクリイタ 18-20MM	FEED PLATE (18-20MM)	
8-6	003400804	2	サラネジ"4X8	SCREW 4X8	
8-7	S21621001	1	シタオクリイタカ"イト"R	BOTTOM FEED PLATE GUIDE (R)	
8-8	S21622001	1	シタオクリイタク"イト"L	BOTTOM FEED PLATE GUIDE (L)	
8-9-1	S21686001	1	スヘ"リイタRクミ8-12	SLIDE PLATE (R) ASSEMBLY (8-12MM)	
8-9-2	S21688001	1	スヘ"リイタRクミ14-16	SLIDE PLATE (R) ASSEMBLY (14-16MM)	
8-9-3	S21690001	1	スヘ"リイタRクミ18-20	SLIDE PLATE (R) ASSEMBLY (18-20MM)	
8-10-1	S21687001	1	スヘ"リイタLクミ8-12	SLIDE PLATE (L) ASSEMBLY (8-12MM)	
8-10-2	S21689001	1	スヘ"リイタLクミ14-16	SLIDE PLATE (L) ASSEMBLY (14-16MM)	
8-10-3	S21691001	1	スヘ"リイタLクミ18-20	SLIDE PLATE (L) ASSEMBLY (18-20MM)	
8-11	100360003	20	サラネジ"2.38	SCREW 2.38	
8-12	S08197001	2	シデンピン	PIN	
8-13	004300602	2	+サラネジ"3X6	SCREW 3X6	
8-14	018501622	1	アナボ"ルト"5X16	BOLT 5X16	
8-15	025050232	1	ヒラサ"カ"ネチユウ5	PLAIN WASHER 5	
8-16	028050242	1	ハ"ネサ"カ"ネ2-5	SPRING WASHER 2-5	
8-17	S09685101	1	アツシユクハ"ネ"	SPRING	

X. 特別注文部品(立ちペダル)/Option parts (Stand pedal)/Sonderzubehör (Standpedal)/
Pièces en option (Pédale à support)/Piezas opcionales (Pedal de soporte)

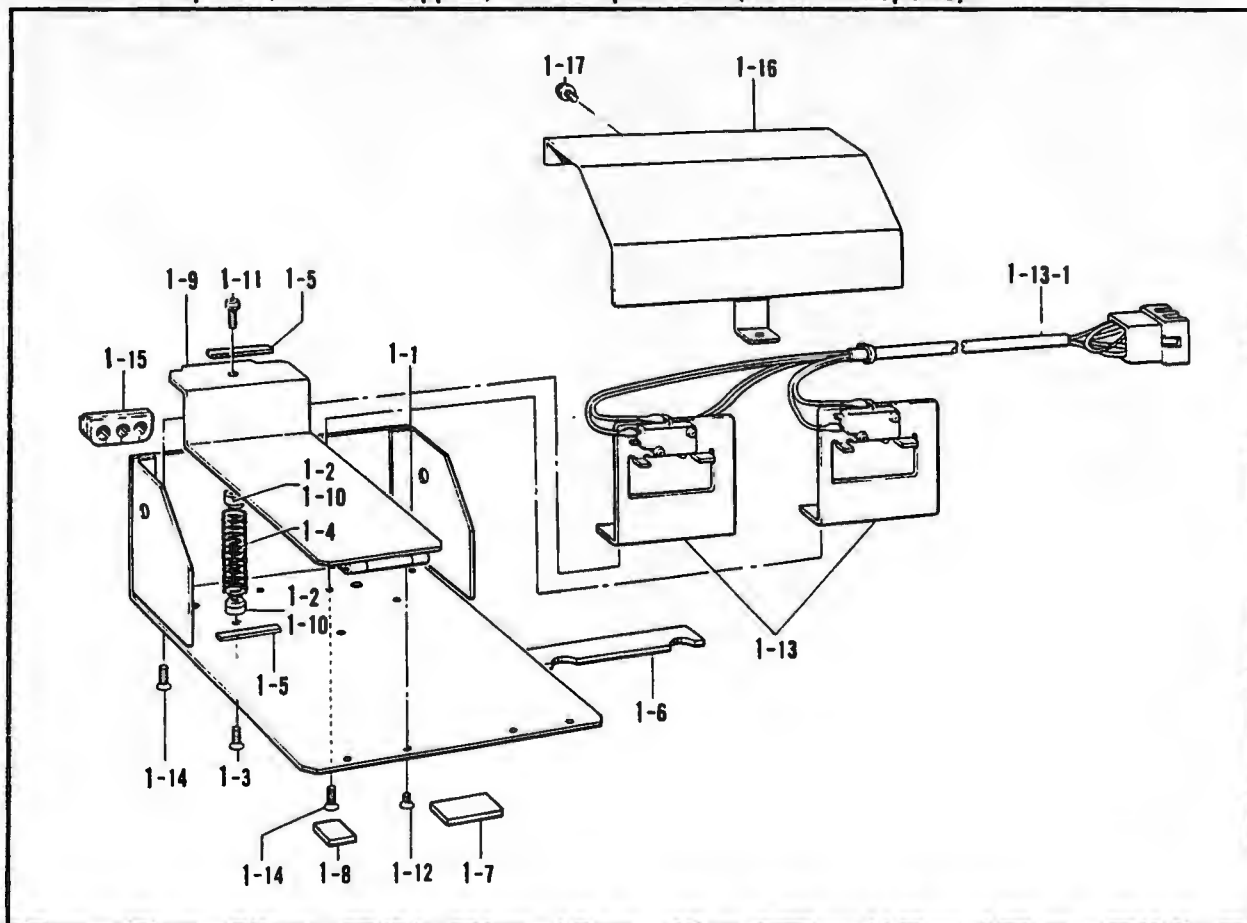

Z1. 付属品関係 (自動機付属)/Accessories (provided with automatic sewing machine)/
Zubehör (mit automatischer Nähmaschine)/
Accessoires (avec la machine à coudre automatique)/
Accesorios (que vienen con la máquina de coser automática)

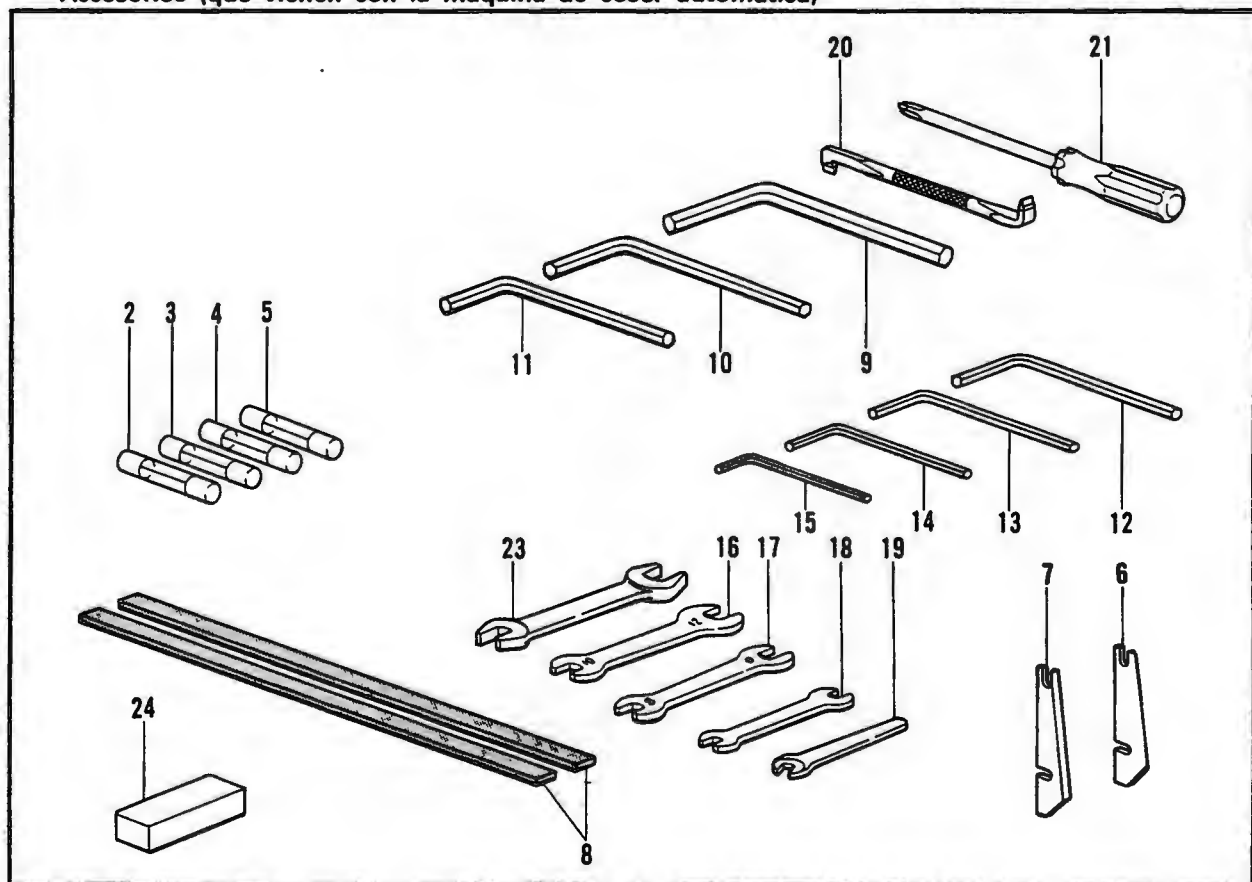

X. 特別注文部品(立ちペダル)/Option parts (Stand pedal)/Sonderzubehör (Standpedal)/
Pièces en option (Pédale à support)/Piezas opcionales (Pedal de soporte)

REF.NO	CODE	Q'TY	ヒンメイ	NAME OF PARTS	RMKS
1	S18091001	1	タッチペダルクミBAS600	STAND PEDAL ASSEMBLY (BAS 600)	
1-1	S14817001	1	タッチペダルベースクミ	STAND PEDAL BASE ASSEMBLY	
1-2	233231001	2	ハネウケ#23	SPRING HOOK #23	
1-3	061401205	2	サラコ4X12	SCREW 4X12	
1-4	233233001	2	オシハネ1.2X12X57	SPRING 1.2X12X57	
1-5	233232001	2	ゴムイタ1.6X5X45	RUBBER PLATE 1.6X5X45	
1-6	S14823001	1	ゴムイタ3.2X20X186	RUBBER PLATE 3.2X20X186	
1-7	233229001	1	ゴムイタ3.2X20X46	RUBBER PLATE 3.2X20X46	
1-8	233230001	2	ゴムイタ3.2X20X15	RUBBER PLATE 3.2X20X15	
1-9	233225001	2	ペダルクミ	PEDAL ASSEMBLY	
1-10	233231001	2	ハネウケ#23	SPRING HOOK #23	
1-11	217093001	2	ナハセツ4X12D	SCREW 4X12D	
1-12	061400402	4	サラコ4X4	SCREW 4X4	
1-13	S18090001	1	M.SWクミ	MICRO SWITCH ASSEMBLY	
1-13-1	S18089001	1	M.SWコードクミ	MICRO SWITCH CORD ASSEMBLY	
1-14	061401205	4	サラコ4X12	SCREW 4X12	
1-15	233250001	1	F.Pフツシング	F.P BUSH	
1-16	S14821109	1	タッチペダルカバークミ	STAND PEDAL COVER ASSEMBLY	
1-17	233236001	3	ナハセツ4X6DA	SCREW 4X6DA	

Z1. 付属品関係 (自動機付属)/Accessories (provided with automatic sewing machine)/
Zubehör (mit automatischer Nähmaschine)/
Accessoires (avec la machine à coudre automatique)/
Accesorios (que vienen con la máquina de coser automática)

REF.NO.	CODE	Q'TY	ヒンメイ	NAME OF PARTS	RMKS
2	141032000	2	ヒューズ	FUSE (2A)	
3	S08030000	1	Gヒューズ5AFB	G FUSE (5AFB)	
4	153242000	1	ヒューズ6A	FUSE (6A)	
5	219225000	1	カンヒューズ8A	FUSE (8A)	
6	S08322001	2	コーナーメスSR	CORNER KNIFE (S-R)	
7	S08302001	2	コーナーメスSL	CORNER KNIFE (S-L)	
8	S08267003	2	オオオサエゴム	CARRIAGE FEED RUBBER	
9	115157001	1	6カクホ"ウスハ"ナ6	HEXAGONAL WRENCH 6	
10	150335001	1	6カクホ"ウスハ"ナ5	HEXAGONAL WRENCH 5	
11	118064001	1	6カクホ"ウスハ"ナ4	HEXAGONAL WRENCH 4	
12	142721001	1	6カクホ"ウスハ"ナ3	HEXAGONAL WRENCH 3	
13	154125001	1	6カクホ"ウスハ"ナ2.5	HEXAGONAL WRENCH 2.5	
14	142002001	1	6カクホ"ウスハ"ナ2	HEXAGONAL WRENCH 2	
15	S07783001	1	6カクホ"ウスハ"ナ1.5	HEXAGONAL WRENCH 1.5	
16	107780001	1	スハ"ナ10X12	SPANNER 10X12	
17	100887001	1	スハ"ナ8X9	SPANNER 8X9	
18	142205001	1	スハ"ナ7X8	SPANNER 7X8	
19	S08132001	1	スハ"ナ5.5	SPANNER 5.5	
20	S08170001	1	Zカ"タネシ"マワシ	Z-STEEL SCREW DRIVER	
21	150332001	1	プラスチック"ライハ"ーNO.2	DRIVER NO.2	
23	S14696001	1	スハ"ナ11X13	SPANNER 11X13	
24	*	1	オオオサエケージ	ADJUST GAUGE	

◎ 付属品の明細は変更することがあります。
◎ The details of included accessories are subject to change.
◎ Änderungen in der Aufstellung der Mitgelieferten Zubehöre sind vorbehalten

◎ Les détails des accessoires inclus sont sujets à des changements
◎ Los detalles de los accesorios incluidos pueden variar.

22. 付属品関係 (頭部付属)/Accessories (provided with machine body)/Zubehör (mit Nähmaschine)/
Accessoires (avec le corps de la machine)/Accesorios (con el cuerpo de la máquina)

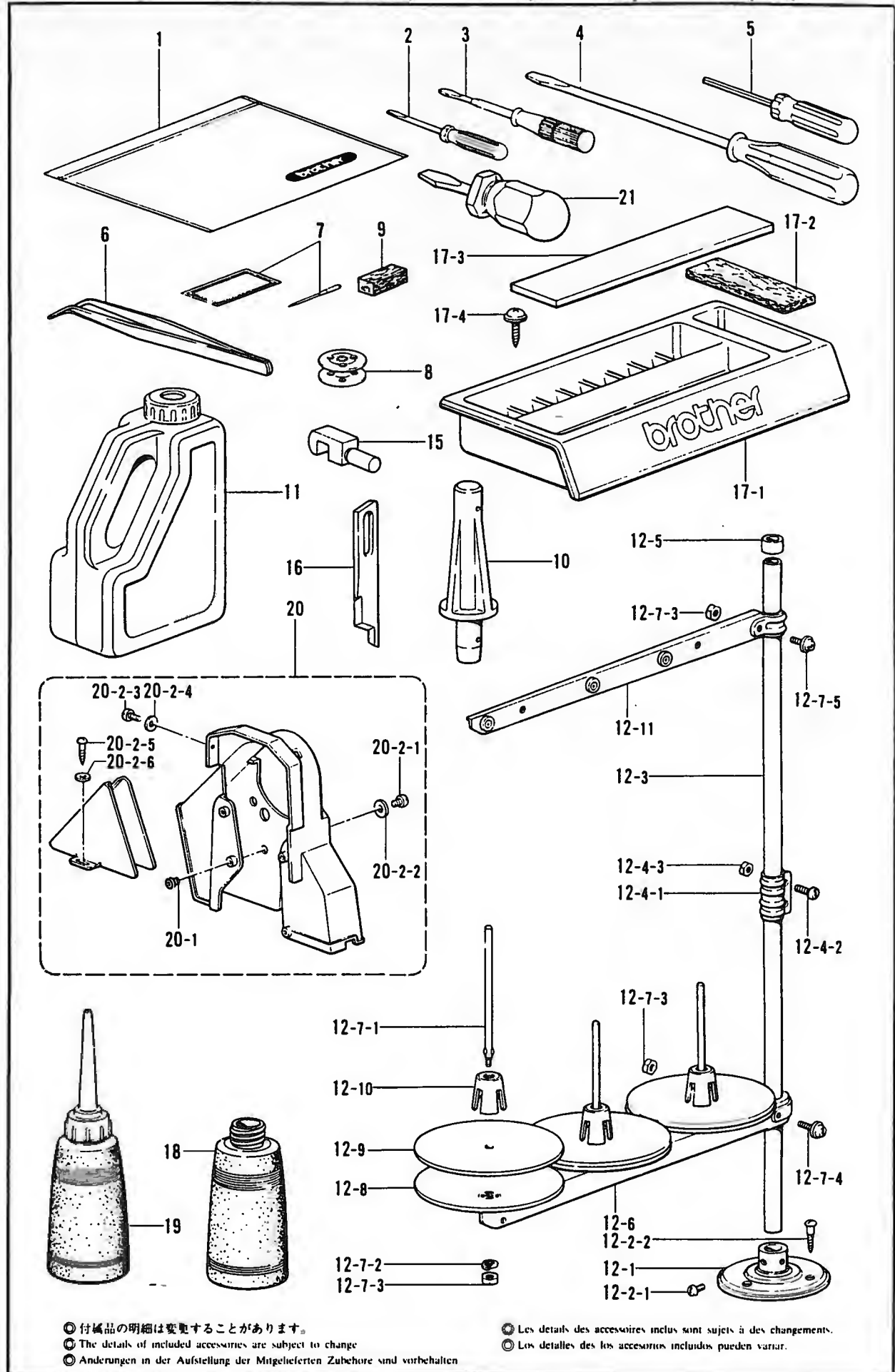

◎ 付属品の明細は変更することがあります。
 ◎ The details of included accessories are subject to change
 ◎ Änderungen in der Aufstellung der Mitgelieferten Zubehöre sind vorbehalten

◎ Les details des accessoires inclus sont sujets à des changements.
 ◎ Los detalles de los accesorios incluidos pueden variar.

22. 付属品関係 (頭部付属)/Accessories (provided with machine body)/Zubehör (mit Nähmaschine)/
Accessoires (avec le corps de la machine)/Accesorios (con el cuerpo de la máquina)

REF NO	CODE	Q'TY	ヒンメイ	NAME OF PARTS	RMKS
1	122991001	1	フソクヒンホリフクロ	ACCESSORY BAG	
2	142443001	1	ネジマフシ1.9X52	SCREW DRIVER 1.9X52	
3	118837001	1	ネジマフシ3.4X70	SCREW DRIVER 3.4X70	
4	101572101	1	ネジマフシ5.5X190	SCREW DRIVER 5.5X190	
5	S01943001	1	6カクホウネジマフシ1.6	SCREW DRIVER 1.6	
6	117466000	1	ピンセット	PINCETTE	
7	153011016	8	ミシンハリMTX190 #16	NEEDLE MTX190 (#16)	
8	S09285001	8	ホビーン	BOBBIN	
9	114941001	2	アームイトアンナイフエルト	FELT	
10	159384009	1	トウフササエマクラ	HEAD REST	
11	154702001	1	オイルタンク	OIL TANK	
12	S02765009	1	イトタテダイクミ3	COTTON STAND ASSEMBLY 3	
12-1	150189009	1	ブラケット	COTTON STAND BASE	
12-2	S02773001	1	ブラケットネジセット	COTTON STAND BASE SCREW SET	
12-2-1	062060806	2	ナヘコ6X8	SCREW 6X8	
12-2-2	031452206	3	マルモク45X22	SCREW 45X22	
12-3	150172003	2	コラムパイプ	COLUMN PIPE	
12-4	150106003	1	コラムジョイントクミ	COLUMN JOINT ASSEMBLY	
12-4-1	150173003	1	コラムジョイント	COLUMN JOINT	
12-4-2	062501406	2	ナヘコ5X14	SCREW 5X14	
12-4-3	021500106	2	1シユナツト5	NUT 5	
12-5	150174000	1	コラムキャップ	COLUMN CAP	
12-6	S02779009	1	スプールホルダー-3	SPOOL HOLDER 3	
12-7	S02782001	1	スプールネジセット3	SPOOL SCREW SET 3	
12-7-1	150179002	3	スプールシャフトB	SPOOL SHAFT (B)	
12-7-2	028050246	3	ハネサガネ2-5	SPRING WASHER 2-5	
12-7-3	021500106	5	1シユナツト5	NUT 5	
12-7-4	050503006	1	ナヘコヒラサ5X30	WASHER SCREW 5X30	
12-7-5	050501406	1	ナヘコヒラサ5X14	WASHER SCREW 5X14	
12-8	150180001	3	ウケサマ	SPOOL STAND BASE	
12-9	150182000	3	スプールマット	SPOOL MAT	
12-10	126863001	3	スプールクッション	SPOOL CUSHION	
12-11	S02788009	1	スレットハンガークミ3	THREAD HANGER ASSEMBLY 3	
15	141256001	2	トウフヒンジ	HEAD HINGE	
16	S16248001	1	ウフメスB	UPPER KNIFE (B)	
17	183400009	1	コモケースセット	ACCESSORY CASE SET	
17-1	S02738009	1	コモケース	ACCESSORY CASE	
17-2	S02740000	1	フェルト	FELT	
17-3	S02739000	1	ゴムジシヤクテープ	RUBBER MAGNET TAPE	
17-4	S10476001	2	ハンフツシヤタツヒンネジ	SCREW	
18	114486002	1	ホリオイラータイ	OILER	
19	114483002	1	ホリオイラークミ	OILER ASSEMBLY	
20	183480009	1	ベルトカバークミ	BELT COVER ASSEMBLY	
20-1	S07660000	4	ゴムカラー	RUBBER COLLAR	
20-2-1	062712012	4	ナヘコ476-32X20	SCREW 476X20	
20-2-2	025050332	4	ヒラサガネ5	PLAIN WASHER 5	
20-2-3	062680812	1	ナヘコ437-40X8	SCREW 437X8	
20-2-4	025680232	1	ヒラサガネチユウ4.37	PLAIN WASHER 4.37	
20-2-5	100666002	2	マルモクネジ5.5X20	SCREW 5.5X20	
20-2-6	025750132	2	ヒラサガネチヨウ5.56	PLAIN WASHER 5.56	
21	S11243001	1	スタビートライバー	DRIVER	

CODE	REF.NO.	PAGE
S00208001	E - 42	6
S00402001	W1- 3-1	64
S00403100	V - 25	58
S00470000	P - 39	32
S00480000	J - 1-11	16
S00554000	Q - 6	34
S00603000	V - 112-4	60
S00614000	V - 112-2	60
S00617000	V - 116	60
S01522000	P - 15-5	32
S01542000	P - 19-5	32
S01698001	R - 21	44
S01830000	U - 1-31	56
S01943001	Z2 - 5	72
S02611001	J - 1-21-1	16
S02612001	J - 1-21-2	16
S02738009	Z2 - 17-1	72
S02739000	Z2 - 17-3	72
S02740000	Z2 - 17-2	72
S02765009	Z2 - 12	72
S02773001	Z2 - 12-2	72
S02779009	Z2 - 12-6	72
S02782001	Z2 - 12-7	72
S02788009	Z2 - 12-11	72
S03289001	G - 60	10
	G - 73	10
S03328000	V - 112-3	60
S03557001	R - 26-18	52
S03566001	J - 1-18	16
S04411001	W2- 6-1-9	66
	W2- 6-2-9	66
S04557000	J - 1-24	16
	K - 1-79	20
	K - 2-29	22
	K - 2-63	24
	P - 36	32
	Q - 18	34
	Q - 21	34
	V - 134	60
	W1- 4-4	64
	W2- 6-18	66
S04607009	W1- 4-1-2	64
S04891000	P - 7	32
S04897000	P - 15-6	32
	P - 19-6	32
S04905000	E - 50-2	6
S04910000	K - 1-22-2	18
	K - 1-38-2	18
	K - 2-41-2	22
	R - 1-54-3	36
S06241000	S - 4	54
S06242001	S - 5	54
S06694001	U - 1-1-3	56
S06736009	K - 2-5	22
S06737000	K - 2-6	22
S06739009	K - 2-11	22
S06740001	K - 2-15	22
S06741001	K - 2-16	22
S06744000	K - 2-25	22
S06857000	P - 8	32
S06858000	P - 8-1	32
S06859000	P - 8-2	32
S06866000	R - 1-54-2	36
S06882000	M - 9-4-2	28
	R - 25-52-2	46
	R - 25-55-3	48
S06883000	M - 1-15-2	28

CODE	REF.NO.	PAGE
S06883000	R - 25-52-3	46
	R - 25-55-2	48
S06886000	K - 2-26-1-2	22
	R - 1-88-2	38
S06890000	R - 26-2-2	52
	R - 35-2	50
	W2- 6-1-6-2	66
	W2- 6-2-6-2	66
S06897000	K - 2-26-1-1	22
S06898000	R - 12-15-2	42
S07026001	V - 69	60
S07320000	V - 141-2	60
	V - 142-2	60
S07330101	B - 3	2
S07334001	B - 22	2
S07338001	B - 24	2
S07339009	B - 26	2
S07340009	B - 19	2
S07417001	F - 9	8
S07419001	F - 8	8
S07420000	F - 7	8
S07423101	F - 19	8
S07424001	F - 20	8
S07430001	F - 28	8
S07431001	F - 30	8
S07432001	F - 38	8
S07433001	F - 39	8
S07434001	F - 34	8
S07435001	F - 36	8
S07436001	F - 24	8
S07437001	F - 25	8
S07439001	D - 4	4
S07442001	D - 7	4
S07446001	D - 6	4
S07447001	D - 6-1	4
S07448001	G - 1	10
S07449000	G - 2	10
S07450109	G - 24	10
S07453000	G - 47	10
S07455100	G - 49	10
S07456000	G - 50	10
S07457100	G - 51	10
S07458100	G - 53	10
S07459100	G - 54	10
S07460100	G - 46	10
S07461000	G - 63	10
S07462000	G - 69	10
S07463000	G - 70	10
S07464100	G - 74	10
S07465000	G - 55	10
S07467001	G - 78	10
S07468000	G - 80	10
S07469001	G - 81	10
S07471001	G - 22	10
S07473000	G - 86	12
S07474000	G - 34	10
S07476000	G - 36	10
S07477000	G - 4	10
S07478000	G - 5	10
S07479101	G - 6	10
S07481009	G - 87	12
S07487001	H - 1-6	14
S07488001	H - 1-10	14
S07489109	H - 1	14
S07490001	H - 1-13	14
S07571000	G - 39	10
S07658001	F - 27	8

CODE	REF.NO.	PAGE
S07660000	Z2 - 20-1	72
S07783001	Z1 - 15	70
S07810000	G - 52	10
S07876001	G - 88	12
	G - 98	12
	G - 99	12
S08007000	K - 1-80-3	20
	K - 2-64-1	24
S08009000	R - 17-2	44
S08017000	K - 1-80-4	20
	K - 2-64-2	24
	R - 17-1-1	44
S08021201	N - 1	30
S08030000	Z1 - 3	70
S08038000	N - 20	30
S08079000	N - 2-1-1	30
	N - 2-2-1	30
S08086000	Q - 7-1	34
S08089001	V - 112	60
S08093000	N - 2-2-2	30
S08098000	Q - 5	34
S08103000	Q - 4	34
S08105000	Q - 8	34
S08106000	Q - 9-1	34
S08108000	Q - 10	34
S08109000	Q - 11	34
S08110000	Q - 12	34
S08113000	Q - 17	34
S08114009	Q - 13	34
S08115000	Q - 14	34
S08116000	Q - 15	34
S08117000	J - 1-8	16
S08124109	K - 2	22
S08125000	K - 2-27	22
S08126000	K - 2-28	22
S08127001	K - 1-80	20
S08130000	K - 2-64	24
S08131000	K - 1-80-1	20
S08132001	Z1 - 19	70
S08134000	K - 3	24
S08135001	K - 1-72	20
	K - 2-57	24
S08136000	P - 12	32
S08137000	R - 24	44
S08138000	K - 1-75	20
S08139000	K - 1-76	20
	K - 2-60	24
S08140000	K - 1-77	20
	K - 2-61	24
S08142001	R - 25-45	46
S08143000	P - 9	32
S08144000	P - 10	32
S08145000	P - 11	32
S08146000	P - 13	32
	W2- 6-16	66
S08147000	P - 14	32
S08148001	R - 25-72	48
S08149001	R - 25-62	48
S08151000	K - 1-72-1	20
	K - 2-57-1	24
	P - 19-1	32
S08152000	K - 1-72-5	20
	K - 2-57-5	24
S08154000	K - 1-72-2	20
	K - 2-57-2	24
S08155000	P - 15-2	32
	P - 19-2	32

CODE	REF.NO.	PAGE
S08159001	P - 19	32
S08163000	P - 22	32
S08164000	P - 23	32
S08165000	P - 24	32
S08166000	P - 25-1	32
S08167000	P - 26-1	32
S08168000	P - 27-1	32
S08169000	P - 28-1	32
S08170001	Z1 - 20	70
S08171000	P - 29	32
S08172000	P - 30	32
	W2- 6-14	66
S08173000	P - 31-1	32
S08174000	P - 32	32
S08175000	P - 33	32
S08176000	P - 34	32
S08177000	P - 35	32
S08178000	P - 16	32
	W2- 6-13	66
S08180000	R - 1-67	38
S08185009	V - 9	58
S08186009	V - 10	58
S08187009	V - 12	58
S08189009	V - 19	58
S08190001	V - 40	58
S08191001	V - 23	58
S08192009	V - 91	60
S08193009	V - 13	58
S08194001	V - 29	58
S08197001	V - 67	58
	W4- 8-12	68
S08200001	V - 59	58
S08201001	V - 64	58
S08205000	V - 54	58
S08206009	V - 73	60
S08207001	R - 25-61	48
S08208001	R - 38	50
S08211001	R - 29-1	50
S08213001	R - 29-2	50
S08214009	R - 33	50
S08215009	R - 29-6	50
S08216001	R - 25-66	48
S08217001	R - 25-31	46
S08220001	V - 125	60
S08221009	V - 80	60
S08222009	V - 82-1	60
S08224001	V - 97	60
S08225001	V - 98	60
S08227001	R - 25	46
S08228001	R - 25-1	46
S08229001	R - 25-5	46
S08230001	R - 25-9	46
S08231000	R - 25-11	46
S08232000	R - 25-12	46
S08233000	R - 25-16	46
S08234001	R - 25-29	46
S08235001	R - 25-32	46
S08237001	R - 25-34	46
S08238000	R - 12-25	42
	R - 12-4	42
	R - 25-35	46
S08239000	R - 12-26	42
	R - 12-5	42
	R - 25-36	46
S08240000	R - 12-27	42
	R - 12-6	42
	R - 25-37	46

CODE	REF.NO.	PAGE
S08241001	R - 25-39	46
S08242000	R - 25-42	46
S08243000	R - 29-3-1	50
S08245001	R - 25-18	46
S08246001	R - 25-19	46
S08247001	R - 25-25	46
S08248001	R - 25-22	46
S08249000	R - 25-47	46
S08250000	R - 25-52	46
S08251000	R - 25-52-1	46
S08252000	R - 25-42-1	46
S08253000	R - 25-56	48
S08254001	R - 25-68	48
S08255001	R - 25-69	48
S08256001	R - 25-63	48
S08257001	R - 25-75	48
S08258101	R - 25-77	48
S08259101	R - 25-78	48
S08260001	R - 25-80	48
S08261001	R - 25-81	48
S08262001	R - 62-2	52
S08263001	R - 63-2	52
S08264001	R - 25-84	48
S08266001	R - 73	52
S08267003	W2- 6-17	66
	Z1 - 8	70
S08268001	R - 26-1	52
S08270001	V - 32	58
S08271000	R - 26-2	52
S08272000	R - 26-2-1	52
S08273001	R - 26-5	52
S08275001	R - 26-9	52
S08276001	R - 26-10	52
S08277001	R - 26-12	52
S08278001	R - 26-13	52
S08279000	R - 26-17	52
S08280000	R - 1-9	36
S08281001	R - 26	52
S08282101	R - 1	36
S08283001	V - 36	58
S08284001	R - 1-1	36
S08285001	R - 2	38
S08286000	R - 1-2	36
S08287000	R - 8	38
S08288000	R - 11	38
S08289001	R - 1-3	36
S08290001	R - 1-5	36
S08291001	R - 1-6	36
S08292000	R - 1-7	36
S08293001	R - 1-10	36
S08294001	R - 1-12	36
S08295000	R - 1-16	36
S08296001	R - 1-79	38
S08297001	R - 1-78	38
S08300001	R - 1-22	36
	R - 1-36	36
S08301001	R - 1-26	36
S08302001	Z1 - 7	70
S08303001	R - 1-64	38
S08304001	R - 1-30	36
S08306000	R - 1-32	36
S08308001	R - 1-65	38
S08315000	R - 1-93	38
S08317001	R - 1-44	36
S08318001	R - 1-47	36
S08320001	R - 1-52	36
S08322001	Z1 - 6	70

CODE	REF.NO.	PAGE
S08323000	R - 1-54	36
S08324000	R - 1-54-1	36
S08325001	R - 1-55	36
S08326000	R - 1-56	36
S08327001	R - 1-57	38
S08328001	R - 1-59	38
S08329001	R - 1-63	38
S08332000	R - 12-24	42
	R - 12-3	42
	R - 25-33	46
S08333001	R - 12-8	42
S08334001	R - 12-28	42
S08335000	R - 12-15	42
S08336000	R - 12-15-1	42
S08338001	R - 12-21	42
S08339001	R - 12-22	42
S08340001	R - 12-29	42
S08341009	R - 12-20	42
S08342001	R - 12-7	42
S08343000	R - 12-31	42
S08344001	R - 12-34	42
S08345001	R - 12-37	42
S08346001	R - 12-44	42
S08347009	R - 12-47	42
S08348001	R - 12-48	42
S08349001	R - 12-51	42
S08350001	R - 12-54	42
S08352000	K - 2-26-2	22
	R - 12-16	42
S08355001	R - 12-64	44
S08356001	R - 12-56	42
S08360001	R - 12-10	42
S08361000	K - 1-78	20
	K - 2-62	24
	W3- 7-13	68
S08363001	K - 1-1	18
S08364009	R - 12-69	44
S08365001	R - 13	44
S08367000	R - 17-1	44
S08368001	V - 30	58
S08372001	R - 12-75	44
S08377001	M - 9-2	28
S08381001	M - 9-8	28
S08382001	M - 9-9	28
S08383001	M - 9-12	28
S08384001	M - 9-14	28
S08386001	M - 9-16	28
S08387000	M - 9-4	28
S08388000	M - 9-4-1	28
S08397000	M - 1-2	28
	R - 25-58	48
S08398009	K - 1-52	18
S08400000	R - 1-21	36
S08406000	M - 1-15	28
S08407000	M - 1-15-1	28
S08408000	E - 53	6
S08409009	U - 1	56
S08411001	U - 1-8	56
S08412001	U - 1-8-1	56
S08413001	U - 1-10	56
S08416000	U - 1-11	56
S08417000	U - 1-12	56
S08418000	U - 1-14	56
S08419001	U - 1-16	56
S08420000	U - 1-17	56
S08421000	U - 1-19	56
S08422000	U - 1-20	56

CODE	REF.NO.	PAGE
S08423001	U - 1-21	56
S08424001	U - 1-25	56
S08426009	U - 1-29	56
S08427001	V - 93	60
S08431109	K - 1	18
S08432001	K - 1-1-1	18
S08433000	K - 1-1-2	18
S08434001	K - 1-4	18
S08435001	K - 1-5	18
S08436001	K - 1-7	18
S08437001	K - 1-8	18
S08438001	K - 1-11	18
S08439001	K - 1-12	18
S08440000	K - 1-13	18
S08441001	K - 1-14	18
S08442001	K - 1-15	18
S08443001	K - 1-18	18
S08444000	K - 1-20	18
S08445001	K - 1-21	18
S08446000	K - 1-22	18
S08447000	K - 1-22-1	18
S08448001	K - 1-23	18
S08449009	K - 1-37	18
S08450009	K - 1-27	18
S08458009	K - 1-52-1	18
S08459000	K - 1-52-2	18
	K - 1-56	20
S08460001	K - 1-57	20
S08470009	K - 1-64	20
S08471009	K - 1-68	20
S08488000	M - 1-15-3	28
	R - 1-54-4	36
S08489000	R - 25-55-1	48
S08493000	R - 25-55	48
S08498000	R - 25-42-2	46
	R - 29-3-2	50
S08499000	R - 29-3	50
S08500000	M - 1-15-4	28
S08501000	R - 1-54-5	36
S08502000	R - 17	44
S08507000	R - 25-57	48
S08509001	R - 1-66	38
	R - 1-95	38
	R - 25-67	48
	R - 26-19	52
S08514001	K - 1-35	18
	K - 2-38	22
S09132001	C - 5	4
S09141000	P - 43	32
S09142000	V - 138	60
S09153001	R - 1-74	38
S09155000	R - 1-69	38
S09156000	R - 1-69-1	38
S09157000	R - 1-20	36
S09170000	R - 1-96	38
S09174000	R - 35	50
S09175000	R - 35-1	50
S09252001	B - 21	2
S09255201	F - 1	8
S09259001	F - 5	8
S09260001	F - 6-1	8
S09261001	F - 6-2	8
S09262101	F - 15	8
S09264001	F - 23	8
S09268001	F - 23-1-1	8
S09273001	F - 23-1-2	8
S09278001	F - 23-2	8

CODE	REF.NO.	PAGE
S09284001	F - 23-2-4	8
S09285001	F - 41	8
	Z2 - 8	72
S09287000	D - 1	4
S09288000	D - 2	4
S09364000	G - 94	12
S09369000	G - 93	12
S09399009	J - 1	16
S09400009	J - 1-1	16
S09401001	J - 1-2	16
S09402101	J - 1-6	16
S09403009	J - 1-14	16
S09406000	K - 1-38	18
	K - 2-41	22
S09407000	K - 1-38-1	18
	K - 2-41-1	22
S09446001	R - 26-20	52
S09447009	R - 29	50
S09448000	V - 147	62
	V - 15	58
S09449001	V - 63	58
S09450001	V - 99	60
S09618001	K - 1-43	18
	K - 2-52	22
S09619001	K - 1-44	18
	K - 2-55	22
S09670001	B - 20	2
S09685101	R - 1-97	38
	W4- 8-17	68
S09687009	W1- 2-1	64
S09690001	V - 74	60
S10167000	G - 72	10
S10268001	W2- 6-1-5	66
	W2- 6-2-5	66
S10287000	Q - 9-2	34
S10476001	Z2 - 17-4	72
S10540000	R - 10	38
S10551001	R - 26-3	52
S10557000	P - 44	32
S10559009	V - 82	60
S10659001	R - 62-1	48
S10660001	R - 63-1	48
S11083000	W1- 5-1-1	64
S11084001	W1- 5-2	64
S11148001	W1- 3	64
S11243001	Z2 - 21	72
S11334001	W1- 4-1	64
S11335009	W1- 4-1-1	64
S11336009	W1- 4-1-7	64
S11337000	Q - 27	34
S11338000	Q - 28	34
S11426000	W2- 6-7-3	66
S11502009	W1- 2	64
S11503009	W1- 4	64
S11504001	W1- 5	64
S11505000	W1- 5-1	64
S11506000	W1- 5-1-2	64
S11685000	K - 2-26-1	22
S12445001	D - 5	4
S12642001	W2- 6-1-7	66
	W2- 6-2-7	66
S13021001	F - 16	8
S13084001	R - 25-91	48
S13570001	W2- 6-1-1	66
S13571001	W2- 6-2-1	66
S13572001	W2- 6-1-2	66
S13573001	W2- 6-2-2	66

CODE	REF.NO.	PAGE
S13574000	W2- 6-1-6	66
	W2- 6-2-6	66
S13575000	W2- 6-1-6-1	66
	W2- 6-2-6-1	66
S13576100	W2- 6-1-3	66
	W2- 6-2-3	66
S13577000	W2- 6-7	66
S13578000	W2- 6-7-1	66
S13579001	W2- 6-10	66
S13615001	F - 23-1	8
S13638001	R - 1-85	38
S13639000	R - 1-88	38
S13640000	R - 1-88-1	38
S13641001	R - 1-90	38
S14050001	T - 3-1	54
S14051001	T - 3-2	54
S14062001	W2- 6-6	66
S14063001	W2- 6-5	66
S14091001	W3- 7-5	68
S14118000	Q - 30	34
S14145000	W2- 6-7-2	66
S14146000	W2- 6-15	66
S14155009	W3- 7	68
S14156009	W3- 7-1	68
S14157001	W3- 7-7	68
S14158000	W3- 7-7-1	68
S14159000	W3- 7-7-2	68
S14160000	W3- 7-11	68
S14161000	W3- 7-12	68
S14189000	G - 100	12
S14197000	U - 1-28	56
S14412000	Q - 1	34
S14413000	Q - 2	34
S14414001	Q - 16	34
S14640009	A - 2	2
S14642001	E - 2	6
S14643001	E - 11	6
S14647001	E - 14	6
S14649001	E - 15	6
S14650001	E - 16	6
S14651001	E - 17	6
S14652001	E - 21-3	6
S14653001	E - 25	6
S14654001	E - 26	6
S14655001	E - 28	6
S14656001	E - 30	6
S14657001	E - 32	6
S14658001	E - 34	6
S14659001	E - 41	6
S14660001	E - 43	6
S14661009	E - 45	6
S14665000	E - 50	6
S14666000	E - 50-1	6
S14667001	E - 51	6
S14668001	B - 5	2
S14674001	E - 3	6
S14675001	S - 6	54
S14677001	H - 5	14
S14685001	G - 127	12
S14689001	M - 1-1	28
S14690001	M - 1-12	28
S14691009	M - 1-14	28
S14692001	M - 9-1	28
S14693001	M - 9-5	28
S14694001	M - 9-6	28
S14696001	Z1 - 23	70
S14700001	R - 12-2	42

CODE	REF.NO.	PAGE
S14703001	R - 12-73	44
S14704200	R - 12-77	44
S14705000	R - 12-77-1	44
S14753001	R - 45	38
S14754001	R - 1-51	36
S14795109	V - 2	58
S14796101	V - 44	58
S14797001	V - 49	58
S14798001	V - 50	58
S14799001	R - 1-31	36
S14800001	R - 12-58	42
S14801001	R - 12-57	42
S14802001	M - 1-9	28
S14817001	X - 1-1	70
S14821109	X - 1-16	70
S14823001	X - 1-6	70
S15061009	K - 1-48	18
S15062009	K - 1-59	20
	K - 2-47	22
S15063009	K - 2-1	22
S15064001	K - 2-10	22
S15065009	K - 2-30	22
S15066009	K - 2-40	22
S15067001	V - 120	60
S15068101	F - 2	8
S15076101	P - 15	32
S15077000	P - 15-1	32
S15096000	H - 12	14
S15097000	H - 12-1	14
S15201001	R - 1-70	38
S15202001	R - 1-98	38
S15203000	R - 40	38
S15361001	Q - 3	34
S15572109	N - 2-1	30
S15572110	N - 2-1	30
S15576109	N - 2-2	30
S15576110	N - 2-2	30
S15580001	C - 1	4
S15590001	R - 1-82	38
S15591001	R - 1-92	38
S15601009	V - 8	58
S15602009	T - 5	54
S15604009	T - 5	54
S15606009	T - 5	54
S15673001	V - 89	60
S15814109	R - 12	42
S15815001	R - 12-1	42
S15871000	H - 12-2	14
S15890001	W2- 6	66
S15891001	W2- 6-1	66
S15892001	W2- 6-2	66
S16114001	G - 7	10
S16146009	M - 1	28
S16147001	M - 9	28
S16162000	P - 1	32
S16198000	Q - 7-2	34
S16248001	E - 36	6
	Z2 - 16	72
S16255001	V - 121	60
S16607001	R - 76	52
S16608001	R - 26-23	52
S16609001	R - 26-24	52
S16612009	Q - 20	34
S16660101	N - 1	30
S16667000	L - 1-28-1	26
S16669000	L - 1-33	26
S18087001	G - 129	12

CODE	REF.NO.	PAGE
S18089001	X - 1-13-1	70
S18090001	X - 1-13	70
S18091001	X - 1	70
S18385000	G - 133	12
S18707041	V - 119	60
S18944000	R - 12-61	44
S18945000	R - 12-62	44
S19900000	R - 12-77-2	44
S21195001	G - 82	12
S21196001	G - 134	12
S21203001	L - 1-28	26
S21224000	R - 1-35	36
S21225000	R - 1-34	36
S21407001	R - 1-40	36
S21575001	Q - 7-3	34
S21616001	W4 8	68
S21617001	W4 8	68
S21618001	W4 8	68
S21619001	W4 8-1	68
S21620001	W4 8-2	68
S21621001	W4 8-7	68
S21622001	W4 8-8	68
S21623000	W4 8-5-1	68
S21624000	W4 8-5-2	68
S21625000	W4 8-5-3	68
S21686001	W4 8-9-1	68
S21687001	W4 8-10-1	68
S21688001	W4 8-9-2	68
S21689001	W4 8-10-2	68
S21690001	W4 8-9-3	68
S21691001	W4 8-10-3	68
002301003	W2- 6-8	66
002301203	V - 104	60
002402502	K - 1-81	20
003400804	W4 8-6	68
004300513	L - 1-3	26
	R - 29-7	50
	R - 64	48
004300602	V - 68	58
	W4 8-13	68
004301003	V - 75	60
004401003	R - 25-90	48
	R - 34	50
	V - 135	60
008300604	V - 90	60
	V - 94	60
008400604	U - 1-30	56
	V - 11	58
	V - 122	60
	V - 14	58
	V - 156	62
	W1- 2-2	64
013710512	F - 10	8
013711012	F - 17	8
013719412	A - 8	2
013780710	B - 4	2
	C - 4	4
013781012	B - 2	2
	B - 23	2
	D - 3	4
	E - 10	6
	E - 18	6
	E - 27	6
	E - 29	6
	E - 8	6
014060622	K - 1-36	18
	K - 2-39	22

CODE	REF.NO.	PAGE
014060622	R - 1-11	36
	R - 1-4	36
	R - 12-23	42
	R - 12-30	42
014300332	L - 1-7	26
	R - 12-76	44
	R - 43	38
014300522	R - 12-82	44
014400422	M - 9-3	28
	R - 1-53	36
	R - 12-55	42
	R - 12-65	44
	R - 46	40
014400522	R - 26-11	52
014400822	U - 1-13	56
014500522	J - 1-22	16
	K - 1-63	20
	K - 2-21	22
	K - 2-51	22
	R - 1-58	38
	R - 1-80	38
	R - 25-26	46
	W3- 7-6	68
014501222	R - 25-30	46
	R - 25-76	48
	R - 9	38
014680422	L - 1-10	26
014680622	F - 33	8
	F - 37	8
014760622	V - 114	60
014771022	B - 15	2
	D - 6-4	4
	D - 8	4
	B - 16	2
016771032	V - 115	60
017062503	V - 70	60
017082203	V - 70	60
018061222	P - 2	32
018061622	K - 1-65	20
	R - 1-71	38
	V - 55	58
018062022	R - 1-89	38
	R - 12-38	42
	R - 25-48	46
	V - 37	58
	V - 45	58
018062522	K - 1-60	20
	K - 2-48	22
	R - 1-17	36
	R - 3	38
	R - 70	40
018063022	C - 5-1	4
018081222	K - 1-32	18
	K - 2-17	22
	K - 2-35	22
018082022	K - 1-28	18
	K - 1-49	18
	K - 2-2	22
	K - 2-31	22
	U - 1-5	56
	V - 41	58
	W3- 7-2	68
018082522	K - 2-12	22
	R - 12-17	42
	R - 25-13	46
	V - 48	58
018083022	R - 25-2	46
	R - 25-6	46

CODE	REF.NO.	PAGE	
018300622	M - 9-13	28	
	M - 9-15	28	
018300822	M - 1-10	28	
	M - 1-3	28	
	M - 1-6	28	
	R - 1-27	36	
018301222	R - 12-49	42	
	R - 12-52	42	
	R - 12-59	42	
018400622	W1- 4-1-8	64	
018400822	R - 25-73	48	
	W2- 6-3	66	
018401022	K - 1-2	18	
	M - 3	28	
	R - 25-10	46	
018401222	W4- 8-3	68	
	M - 9-7	28	
	R - 1-13	36	
	R - 25-59	48	
	R - 47	40	
	U - 1-22	56	
	V - 100	60	
018401422	R - 26-14	52	
018401622	R - 1-86	38	
	R - 25-70	48	
	U - 1-32	56	
	V - 51	58	
	V - 6	58	
	V - 65	58	
	R - 25-53	46	
	R - 29-4	50	
	R - 41	38	
	V - 101	60	
018403022	M - 2	28	
018500822	R - 27	50	
	V - 33	58	
018501022	K - 1-69	20	
	R - 25-17	46	
018501222	R - 12-66	44	
	V - 20	58	
018501422	R - 1-83	38	
	R - 25-20	46	
	V - 3	58	
	V - 3	58	
018501622	K - 1-24	18	
	K - 1-46	18	
	K - 2-53	22	
	M - 10	28	
	R - 1-41	36	
	R - 1-60	38	
	R - 12-35	42	
	R - 12-41	42	
	R - 12-45	42	
	R - 12-70	44	
	R - 14	44	
	R - 25-79	48	
	R - 30	50	
	R - 6	38	
	W4- 8-14	68	
	018502022	K - 1-16	18
		R - 1-48	36
		R - 1-75	38
		R - 18	44
		R - 25-27	46
	R - 25-40	46	
018502522	R - 25-23	46	
018503022	K - 1-73	20	
	K - 2-58	24	

CODE	REF.NO.	PAGE	
018503022	P - 17	32	
	P - 20	32	
	R - 1-45	36	
018504032	R - 25-88	48	
018505022	K - 2-7	22	
021060102	V - 58	58	
	V - 62	58	
021060106	U - 1-1-4	56	
	U - 1-33	56	
	U - 1-8-2	56	
021060206	R - 25-51	46	
	R - 25-64	48	
021080206	K - 1-9	18	
	R - 1-68	38	
	R - 12-11	42	
021120304	R - 12-9	42	
021200203	V - 26	58	
	W1- 3-2	64	
021300103	J - 1-5	16	
	V - 151	62	
	V - 78	60	
021300303	R - 12-53	42	
	R - 12-60	44	
021400103	L - 1-27	26	
	W1- 2-3	64	
	W1- 5-3	64	
021400202	J - 1-20	16	
	R - 26-8	52	
	R - 29-9	50	
021500103	R - 25-28	46	
021500106	Z2 - 12-4-3	72	
	Z2 - 12-7-3	72	
021670102	H - 1-20	14	
025030133	M - 1-4	28	
	M - 1-7	28	
025030232	R - 75	52	
	R - 1-29	36	
	V - 17	58	
025030233	V - 76	60	
	J - 1-16	16	
	J - 1-3	16	
	L - 1-31	26	
	R - 1-25	36	
	R - 1-39	36	
	R - 25-86	48	
	V - 105	60	
	V - 149	62	
	W1- 4-1-6	64	
	W3- 7-10	68	
025040132	R - 26-16	52	
025040232	M - 4	28	
	R - 1-15	36	
	R - 29-8	50	
	R - 49	40	
	U - 1-23	56	
	V - 102	60	
	V - 7	58	
	025040233	J - 1-13	16
	L - 1-24	26	
	P - 42	32	
	025050232	K - 1-26	18
		K - 1-71	20
		K - 2-8	22
		R - 1-43	36
		R - 1-50	36
R - 1-62		38	
R - 1-77		38	

CODE	REF.NO.	PAGE	
025050232	R - 12-33	42	
	R - 12-43	42	
	R - 12-71	44	
	R - 16	44	
	R - 19	44	
	R - 25-92	48	
	R - 31	50	
	V - 21	58	
	V - 35	58	
	V - 4	58	
	W4- 8-15	68	
	Z2 - 20-2-2	72	
	025050332	K - 1-62	20
		025060232	20
025060336	K - 1-67	20	
	K - 2-50	22	
	P - 3	32	
	R - 1-19	36	
	R - 1-73	38	
	R - 12-40	42	
	R - 25-49	46	
	R - 4	38	
	R - 72	40	
	V - 38	58	
	V - 46	58	
	V - 56	58	
	V - 60	58	
	R - 65	50	
V - 117	60		
025080232	K - 1-30	18	
	K - 1-34	18	
	K - 1-51	18	
	K - 2-13	22	
	K - 2-18	22	
	K - 2-23	22	
	K - 2-3	22	
	K - 2-33	22	
	K - 2-37	22	
	R - 12-13	42	
	R - 12-19	42	
	R - 25-14	46	
	R - 25-3	46	
	R - 25-7	46	
U - 1-6	56		
V - 71	60		
W3- 7-3	68		
025100232	K - 1-41	18	
	K - 2-44	22	
025680132	F - 35	8	
025680232	Z2 - 20-2-4	72	
025710232	F - 14	8	
	G - 26	10	
025750132	Z2 - 20-2-6	72	
028030242	L - 1-5	26	
	M - 1-11	28	
	M - 1-5	28	
	M - 1-8	28	
	R - 1-28	36	
	R - 12-50	42	
	V - 18	58	
	V - 77	60	
	028030243	J - 1-10	16
		J - 1-17	16
		J - 1-4	16
		M - 9-11	28
		R - 1-24	36
		R - 1-38	36
R - 12-81		44	

CODE	REF.NO.	PAGE
028030243	R - 25-44	46
	R - 25-87	48
	R - 26-22	52
	R - 26-4	52
	R - 26-6	52
	R - 37	50
	R - 77	52
	V - 150	62
	W2- 6-1-10	66
	W2- 6-1-8	66
	W2- 6-2-10	66
	W2- 6-2-8	66
	W2- 6-9	66
	W3- 7-9	68
028040242	K - 1-3	18
	K - 1-82	20
	M - 5	28
	R - 1-14	36
	R - 1-87	38
	R - 25-54	46
	R - 25-60	48
	R - 25-71	48
	R - 25-74	48
	R - 26-15	52
	R - 29-5	50
	R - 42	38
	R - 48	40
	U - 1-24	56
V - 103	60	
V - 52	58	
V - 66	58	
W1- 4-1-9	64	
W1- 4-3	64	
W2- 6-4	66	
W4- 8-4	68	
028040243	L - 1-25	26
	R - 25-46	46
028050242	K - 1-17	18
	K - 1-25	18
	K - 1-47	18
	K - 1-70	20
	K - 1-74	20
	K - 2-54	22
	K - 2-59	24
	K - 2-9	22
	M - 11	28
	P - 18	32
	P - 21	32
	R - 1-42	36
	R - 1-46	36
	R - 1-49	36
R - 1-61	38	
R - 1-76	38	
R - 1-84	38	
R - 12-32	42	
R - 12-36	42	
R - 12-42	42	
R - 12-46	42	
R - 12-67	44	
R - 12-72	44	
R - 15	44	
R - 20	44	
R - 25-21	46	
R - 25-24	46	
R - 25-41	46	
R - 25-89	48	
R - 28	50	

CODE	REF.NO.	PAGE	
028050242	R - 32	50	
	R - 7	38	
	V - 22	58	
	V - 34	58	
028050243	V - 5	58	
	W2- 6-12	66	
	W4- 8-16	68	
	E - 54	6	
028050246	Z2 - 12-7-2	72	
028060242	K - 1-61	20	
	K - 1-66	20	
028060243	K - 2-49	22	
	P - 4	32	
	R - 1-18	36	
	R - 1-72	38	
	R - 1-91	38	
	R - 12-39	42	
	R - 25-50	46	
	R - 25-65	48	
	R - 5	38	
	R - 71	40	
	V - 118	60	
	V - 39	58	
	V - 47	58	
	V - 57	58	
	V - 61	58	
	U - 1-8-3-1	56	
	028080242	K - 1-29	18
		K - 1-33	18
		K - 1-50	18
		K - 2-14	22
K - 2-19		22	
K - 2-24		22	
K - 2-32		22	
K - 2-36		22	
K - 2-4		22	
R - 12-12		42	
R - 12-18		42	
R - 25-15		46	
R - 25-4		46	
R - 25-8		46	
U - 1-7		56	
V - 72		60	
W3- 7-4		68	
028100242		K - 2-45	22
		K - 1-42	18
028100243		Z2 - 12-2-2	72
031452206	L - 2	26	
032311306	V - 152	62	
034311302	V - 79	60	
047301042	L - 1-17	26	
	M - 1-13	28	
047301242	J - 1-7	16	
048020342	K - 1-6	18	
048030342	F - 31	8	
048040342	R - 12-14	42	
048050342	K - 1-45	18	
	K - 2-56	22	
048060342	V - 31	58	
	K - 2-20	22	
048070342	U - 1-27	56	
	K - 1-10	18	
048120142	R - 1-33	36	
050501406	Z2 - 12-7-5	72	
050503006	Z2 - 12-7-4	72	
052400806	J - 1-19	16	
	K - 1-53	18	

CODE	REF.NO.	PAGE
052400806	N - 3	30
	Q - 22	34
	U - 1-15	56
	U - 1-18	56
060660512	L - 1-15	26
	G - 121	12
060670612	R - 12-63	44
061020506	X - 1-12	70
061400402	X - 1-14	70
061401205	X - 1-3	70
062060806	V - 81	60
	Z2 - 12-2-1	72
062300416	R - 25-85	48
	R - 74	52
062300512	R - 26-21	52
062300606	L - 1-30	26
	L - 1-4	26
062300616	J - 1-15	16
	J - 1-9	16
062300806	M - 9-10	28
	R - 1-23	36
062301605	R - 1-37	36
	V - 16	58
062302505	V - 148	62
062302506	R - 12-80	44
062304006	W3- 7-8	68
062400616	R - 36	50
062400812	R - 25-43	46
062401006	J - 1-12	16
	R - 26-7	52
062500812	L - 1-26	26
	P - 41	32
062501406	W2- 6-11	66
062670512	Z2 - 12-4-2	72
	B - 27	2
062670712	G - 102	12
	G - 21	10
062670812	G - 23	10
	G - 83	12
062681612	H - 4	14
	E - 33	6
062680616	C - 1-7	4
	E - 24	6
062680812	G - 3	10
	H - 6	14
062681212	Z2 - 20-2-3	72
	S - 7	54
062681012	F - 29	8
	G - 25	10
062711212	S - 2	54
	G - 11	10
062712012	R - 25-82	48
	Z2 - 20-2-1	72
062751612	E - 4	6
	J - 1-23	16
062761212	G - 130	12
062781412	F - 3	8
062782512	D - 6-2	4
072600480	R - 1-8	36
073010002	R - 25-38	46
073050002	K - 1-19	18
	G - 27	10
081030070	H - 2	14
100064002		

CODE	REF.NO.	PAGE
100136001	L - 1-22	26
100197002	F - 4	8
100250001	B - 7	2
100251001	B - 12	2
	D - 5-2	4
100260001	E - 12-1	6
	E - 47	6
100360003	W4- 8-11	68
100401001	L - 1-21	26
100463001	V - 127	60
100645003	S - 8	54
100666002	Z2 - 20-2-5	72
100887001	Z1 - 17	70
101073001	V - 92	60
101572101	Z2 - 4	72
101706001	B - 11	2
102731004	C - 1-4	4
104821009	G - 31	10
	G - 97	12
	V - 145	62
107030001	C - 1-2	4
107780001	Z1 - 16	70
108254001	H - 1-3	14
108265009	H - 1-5	14
108266001	H - 7	14
108802001	G - 64	10
108960002	F - 26	8
	H - 10	14
110087001	V - 129	60
110161006	F - 13	8
110233001	R - 25-83	48
110563001	E - 20	6
	E - 6	6
111140002	R - 50	40
111191001	G - 96	12
111942001	L - 1-13	26
111943001	L - 1-14	26
112293001	G - 124	12
	G - 61	10
112525000	R - 1-69-2	38
112573101	B - 1	2
112574000	B - 6	2
112576001	B - 13	2
112577101	B - 9	2
112586001	B - 17	2
112588101	C - 1-1	4
112590001	C - 1-3	4
112592001	C - 1-6	4
112593001	C - 1-8	4
112594001	C - 2	4
112658001	H - 8	14
112684001	D - 5-1	4
112700001	F - 27-1	8
112709001	H - 3	14
112712001	H - 1-8	14
112715001	H - 9	14
112717001	G - 10	10
112719001	G - 14	10
112720101	G - 15	10
112721001	C - 1-9	4
112728001	G - 56	10
112734001	G - 38	10
112735000	G - 58	10
112751003	E - 35	6
112753001	G - 40	10
112758009	G - 95	12
113014000	B - 10	2

CODE	REF.NO.	PAGE
113024000	B - 25	2
113050001	E - 44	6
113362001	G - 41	10
113431002	S - 3	54
113653000	G - 59	10
114483002	Z2 - 19	72
114486002	Z2 - 18	72
114693001	G - 57	10
114859001	U - 1-9	56
114909000	V - 24	58
114941001	H - 11	14
	Z2 - 9	72
114967001	V - 128	60
115157001	Z1 - 9	70
115585001	E - 48	6
116795000	G - 125	12
117466000	Z2 - 6	72
117934009	K - 2-46	22
118064001	Z1 - 11	70
118320001	H - 1-7	14
118837001	Z2 - 3	72
119706001	U - 1-2	56
119707003	U - 1-3	56
119708001	U - 1-4	56
119709003	U - 1-1-2	56
122991001	Z2 - 1	72
126863001	Z2 - 12-10	72
131007001	D - 5-3	4
131226001	F - 40	8
133172003	V - 155	62
133792101	U - 1-8-3	56
140620001	E - 52	6
140682001	K - 1-72-3	20
	K - 2-57-3	24
	P - 15-3	32
	P - 19-3	32
	W3- 7-7-3	68
140890009	G - 30	10
141032000	Z1 - 2	70
141256001	Z2 - 15	72
141598001	R - 12-74	44
142002001	Z1 - 14	70
142027001	V - 126	60
142205001	Z1 - 18	70
142268001	G - 20	10
142274009	G - 32	10
	G - 33	10
142443001	Z2 - 2	72
142721001	Z1 - 12	70
143489001	K - 1-80-5	20
143531000	W1- 4-1-7-1	64
143625001	E - 19	6
	E - 5	6
143626000	E - 7	6
143627000	E - 9	6
143637001	E - 21-1	6
143641001	E - 37	6
143642101	E - 38	6
143646000	E - 21-2	6
143669000	G - 48	10
143676000	G - 126	12
143679000	G - 120	12
143936000	G - 123	12
144504001	J - 1-21-3	16
144680001	H - 1-1	14
144682001	H - 1-4	14
144685001	H - 1-15	14









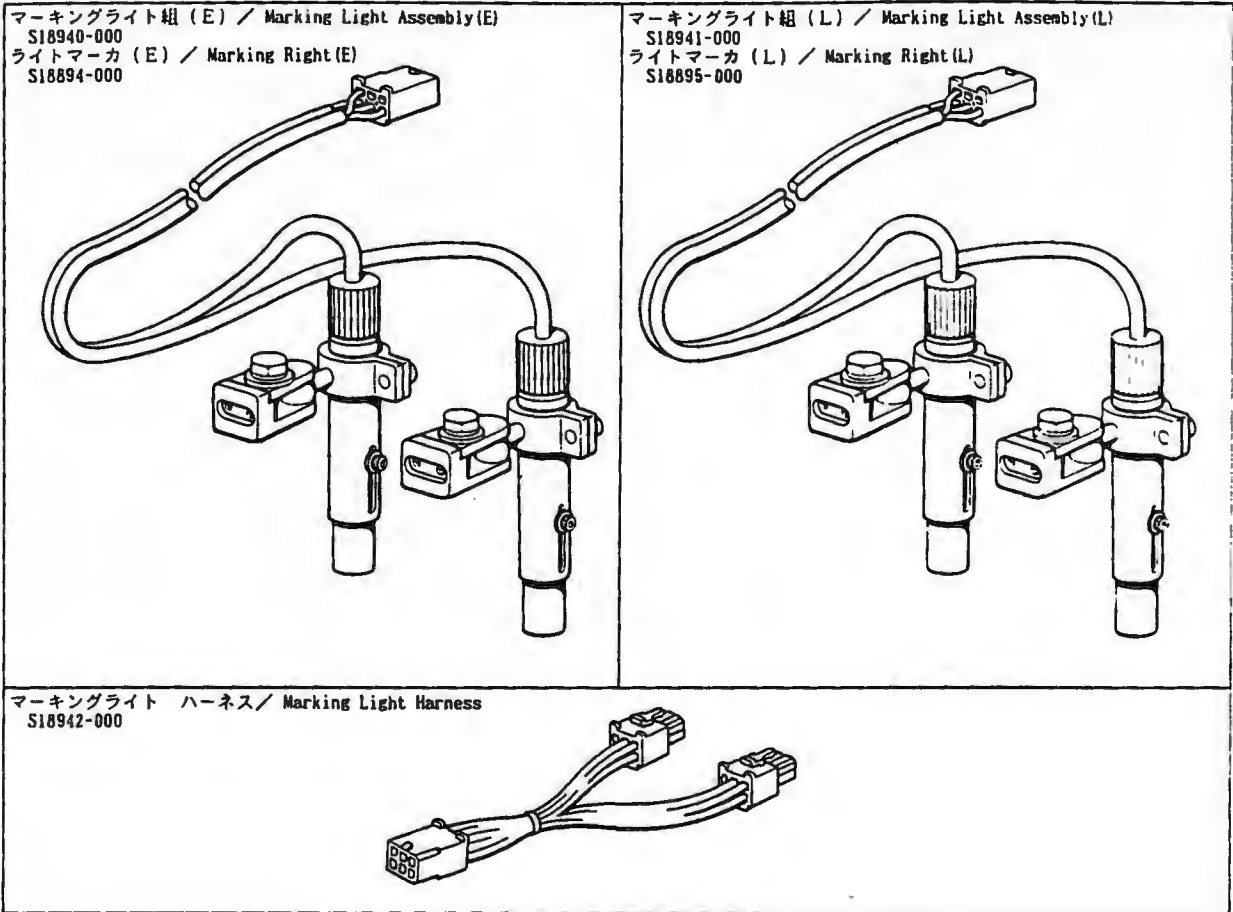



CODE	REF.NO.	PAGE
144686001	H - 1-16	14
144687001	H - 1-17	14
144688001	H - 1-18	14
144689001	H - 1-19	14
145446001	H - 1-11	14
	L - 1-20	26
145571101	L - 1-19	26
146080009	W1- 4-1-7-2	64
146141001	B - 8	2
146197001	L - 1-23	26
146253000	G - 92	12
146354001	R - 12-68	44
146427001	T - 1-1	54
146536001	G - 101	12
146581001	E - 46	6
147843001	U - 1-26	56
147926000	K - 1-80-2	20
147933001	K - 1-58	20
148005001	F - 12	8
148394000	G - 29	10
148539101	E - 40	6
148555001	R - 1-81	38
148762001	G - 37	10
148821001	D - 6-3	4
	D - 9	4
149066001	W1- 4-1-7-3	64
149069101	W1- 4-1-3	64
149070009	W1- 4-1-4	64
149320001	N - 6	30
149342001	K - 1-31	18
	K - 2-34	22
149487001	K - 1-39	18
	K - 2-42	22
149488001	K - 1-40	18
	K - 2-43	22
149547000	W1- 4-5	64
149566009	H - 1-14	14
149796001	P - 5	32
149799000	G - 132	12
149809000	K - 1-83	20
	P - 37	32
	Q - 26	34
	V - 144	62
150106003	Z2 - 12-4	72
150172003	Z2 - 12-3	72
150173003	Z2 - 12-4-1	72
150174000	Z2 - 12-5	72
150179002	Z2 - 12-7-1	72
150180001	Z2 - 12-8	72
150182000	Z2 - 12-9	72
150189009	Z2 - 12-1	72
150191001	V - 82-3	60
150206002	V - 82-2	60
150332001	Z1 - 21	70
150335001	Z1 - 10	70
150349001	V - 136	60
150756009	V - 153	62
150967101	F - 11	8
150988001	G - 9	10
151027001	F - 23-1-1-1	8
151029001	F - 23-2-2	8
151030001	F - 23-2-3	8
151163001	K - 2-22	22
151439002	G - 131	12
151604001	E - 1-1	6
151927001	G - 35	10
152356301	L - 1-1	26







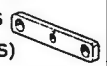

CODE	REF.NO.	PAGE
152357101	L - 1-2	26
152358001	L - 1-6	26
152361001	L - 1-11	26
152362001	L - 1-12	26
152363001	L - 1-16	26
152364001	L - 1-18	26
152645001	L - 1-29	26
152651301	L - 1	26
152974001	G - 128	12
152997001	E - 49	6
153009001	C - 1-5	4
153011016	A - 4-1	2
	Z2 - 7	72
153011018	A - 4-2	2
153012101	C - 3	4
153015001	E - 1	6
153020001	E - 39	6
153024000	G - 122	12
153242000	Z1 - 4	70
153252000	P - 6	32
153274001	K - 1-72-4	20
	K - 2-57-4	24
	P - 15-4	32
	P - 19-4	32
153920001	G - 71	10
154024001	L - 1-8	26
154092001	L - 1-9	26
154125001	Z1 - 13	70
154560001	J - 1-21-4	16
154702001	Z2 - 11	72
155055001	W1- 4-2	64
155491001	H - 1-2	14
156070002	G - 75	10
156096000	W2- 6-7-4	66
156292001	R - 1-94	38
156521001	F - 23-2-1	8
156557001	F - 42	8
158115001	B - 18	2
	D - 7-1	4
158597001	L - 1-32	26
158769001	H - 1-9	14
159150009	A - 9	2
159384009	Z2 - 10	72
159386001	V - 113	60
159436001	F - 32	8
159732001	W2- 6-1-4	66
	W2- 6-2-4	66
159802001	F - 23-2-5	8
159805001	H - 1-12	14
159812001	V - 112-1	60
180157001	B - 14	2
183377001	J - 1-21	16
183387009	U - 1-1-1	56
183400009	Z2 - 17	72
183480009	Z2 - 20	72
183677001	E - 12	6
183699001	E - 21	6
217093001	X - 1-11	70
219225000	Z1 - 5	70
233225001	X - 1-9	70
233229001	X - 1-7	70
233230001	X - 1-8	70
233231001	X - 1-10	70
	X - 1-2	70
233232001	X - 1-5	70
233233001	X - 1-4	70
233236001	X - 1-17	70

CODE	REF.NO.	PAGE
233250001	X - 1-15	70
237950001	S - 1	54
522990001	W1- 4-1-5	64
552851001	L - 1-28-2	26
552907000	P - 40	32
554482000	P - 38	32

特別注文部品 (マーキングライト)/Option parts (Marking light)/Sonderzubehör (Markierungsleuchte)/
Pièces en option (Lampe de marquage)/Piezas opcionales (Luz de marcación)













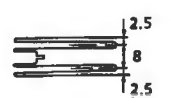

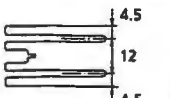
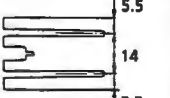

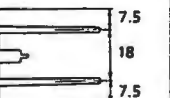
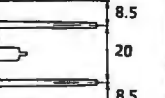
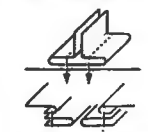

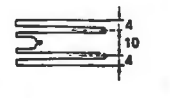
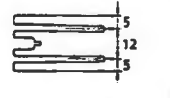
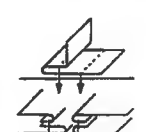

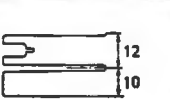

品名 Name of Parts	参照番号 Ref. No.	個数 Q'ty	針 巾 Needle Gauge							
			8 m/m	10m/m	12m/m	14m/m	16m/m	18m/m	20m/m	
糸切り Thread Trimmer	上糸切り移動刃 Needle Thread Trimmer Movable Knife 	M-6	1	ウワイトメス 8~12 Needle Thread Knife (8~12) (S08403-001)			ウワイトメス 14~16 Needle Thread Knife (14~16) (S10527-001)		ウワイトメス 18~20 Needle Thread Knife (18~20) (S10552-001)	
	上糸切り固定刃 Needle Thread Trimmer Fixed Knife 	M-7	1	コテイハ 8~12 Fixed Knife (8~12) (S08399-001)			コテイハ 14~16 Fixed Knife (14~16) (S10528-001)		コテイハ 18~20 Fixed Knife (18~20) (S10553-001)	
	上糸切り糸保持バネ Needle Thread Trimmer Thread Retainer Spring 	M-8	1	イトホジバネ 8~12 Thread Retainer Spring (8~12) (S08401-001)			イトホジバネ 14~16 Thread Retainer Spring (14~16) (S10529-001)		イトホジバネ 18~20 Thread Retainer Spring (18~20) (S10554-001)	
	下糸切りリンク Lower Thread Trimmer Link 	M-12	1	リンクB Link (B) (S08385-001)	リンクB Link (B) (S08385-002)	リンクB Link (B) (S08385-003)	リンクB Link (B) (S08385-004)	リンクB Link (B) (S08385-005)	リンクB Link (B) (S08385-006)	リンクB Link (B) (S08385-007)
生地ガイドアーム用 Cloth Guide for Arm	スペーサ使用個数 Q'ty of Spacer 	R-12-56	0	2	4	4	4	4	4	
コーナーメス Corner Knife	台 Base 	R-44	2	メスダイ 8クミ Knife Base Ass. 8 (S11521-001)	メスダイ 10クミ Knife Base Ass. 10 (S11522-001)	メスダイ 12クミ Knife Base Ass. 12 (S11523-001)	メスダイ 14クミ Knife Base Ass. 14 (S11524-001)	メスダイ 16クミ Knife Base Ass. 16 (S11525-001)	メスダイ 18クミ Knife Base Ass. 18 (S11526-001)	メスダイ 20クミ Knife Base Ass. 20 (S11527-001)
	刃 (右側) Right Knife 	R-52	2	コーナーメスSR Corner Knife (S-Right) (S08322-001)				コーナーメスLR Corner Knife (L-Right) (S09416-001)		
	刃 (左側) Left Knife 	R-53	2	コーナーメスSL Corner Knife (S-Left) (S08302-001)				コーナーメスLL Corner Knife (L-Left) (S09417-001)		
バインダー・片玉 Binder・Single Welting		R-68	1	オリコミイタオサエ Folding Plate Supporter (S11520-001)						
		R-69	2	+サラネジ 3×5 Screw 3×5 (004300-513)						
大押し調節ゲージ Carriage Feed Adjusting Gauge		R-58	1	イドウダイスパーサ Movable Base Spacer (S08513-001)	イドウダイスパーサ Movable Base Spacer (S08513-002)	イドウダイスパーサ Movable Base Spacer (S08513-003)	イドウダイスパーサ Movable Base Spacer (S08513-004)	イドウダイスパーサ Movable Base Spacer (S08513-005)	イドウダイスパーサ Movable Base Spacer (S08513-006)	イドウダイスパーサ Movable Base Spacer (S08513-007)
		Z1-24	1	オオオサエゲージ Adjust Gauge (S08512-001)	オオオサエゲージ Adjust Gauge (S08512-002)	オオオサエゲージ Adjust Gauge (S08512-003)	オオオサエゲージ Adjust Gauge (S08512-004)	オオオサエゲージ Adjust Gauge (S08512-005)	オオオサエゲージ Adjust Gauge (S08512-006)	オオオサエゲージ Adjust Gauge (S08512-007)

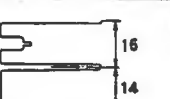
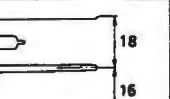
品名 Name of Parts		参照番号 Ref. No.	個数 Q'ty	針 巾 Needle Gauge							
				8 m/m	10m/m	12m/m	14m/m	16m/m	18m/m	20m/m	
スパーサ Spacer	大押え用 For Carriage Feed	スパーサS Spacer (S) 	R-56	2	t=6 (S08510-001)	t=5 (S08510-002)	t=4 (S08510-003)	t=3 (S08510-004)	t=2 (S08510-005)	t=1 (S08510-006)	—
		スパーサW Spacer (W) 	R-57	2	t=3.5 (S08511-001)	t=4.5 (S08511-002)	t=5.5 (S08511-003)	t=6.5 (S08511-004)	t=7.5 (S08511-005)	t=8.5 (S08511-006)	t=9.5 (S08511-007)
	折り込み板用 For Folding Plate	スパーサS Spacer (S) 	R-60	2	t=8.5 (S09688-001)	t=7.5 (S09688-002)	t=6.5 (S09688-003)	t=5.5 (S09688-004)	t=4.5 (S09688-005)	t=3.5 (S09688-006)	—
		スパーサW Spacer (W) 	R-61	2	t=3.5 (S09689-001)	t=4.5 (S09689-002)	t=5.5 (S09689-003)	t=6.5 (S09689-004)	t=7.5 (S09689-005)	t=8.5 (S09689-006)	t=9.5 (S09689-007)
フラップ用ゲージ Gauge for Flap 		R-66	2	フラップスパーサ Flap Spacer (S11304-001)	フラップスパーサ Flap Spacer (S11304-002)	フラップスパーサ Flap Spacer (S11304-003)	フラップスパーサ Flap Spacer (S11304-004)	フラップスパーサ Flap Spacer (S11304-005)	フラップスパーサ Flap Spacer (S11304-006)	フラップスパーサ Flap Spacer (S11304-007)	フラップスパーサ Flap Spacer (S11304-007)
		R-67	4	—	ナベコ 3×16 Screw 3×16 (062301-605)	ナベコ 3×20 Screw 3×20 (062302-005)	ナベコ 3×25 Screw 3×25 (062302-505)	ナベコ 3×25 Screw 3×25 (062302-505)	ナベコ 3×25 Screw 3×25 (062302-505)	ナベコ 3×25 Screw 3×25 (062302-505)	ナベコ 3×25 Screw 3×25 (062302-505)
生地滑り板 Cloth Slide Plate	右側 Right 	V-141	1	キジスベリイタRクミ Slide Plate (Right) Assembly (S08195-001)			キジスベリイタRクミ Slide Plate (Right) Assembly (S09452-001)		キジスベリイタRクミ Slide Plate (Right) Assembly (S09453-001)		
		V-141-1	1	キジスベリイタR Slide Plate (Right) (S08196-001)			キジスベリイタR Slide Plate (Right) (S08196-002)		キジスベリイタR Slide Plate (Right) (S08196-003)		
	左側 Left 	V-142	1	キジスベリイタLクミ Slide Plate (Left) Assembly (S08198-001)			キジスベリイタLクミ Slide Plate (Left) Assembly (S09454-001)		キジスベリイタLクミ Slide Plate (Left) Assembly (S09455-001)		
		V-142-1	1	キジスベリイタL Slide Plate (Left) (S08199-001)			キジスベリイタL Slide Plate (Left) (S08199-002)		キジスベリイタL Slide Plate (Left) (S08199-003)		
頭部 Machine Head	針抱き Needle Clamp 	T-1	1	ハリダキ 8 クミ Needle Clamp Ass. 8 (S00935-001)	ハリダキ 10 クミ Needle Clamp Ass. 10 (158810-001)	ハリダキ 12 クミ Needle Clamp Ass. 12 (158811-001)	ハリダキ 14 クミ Needle Clamp Ass. 14 (S09466-001)	ハリダキ 16 クミ Needle Clamp Ass. 16 (S00936-001)	ハリダキ 18 クミ Needle Clamp Ass. 18 (S09468-001)	ハリダキ 20 クミ Needle Clamp Ass. 20 (S00937-001)	
	針板 Needle Plate 	T-2	1	ハリイタ 8 Needle Plate 8 (S09461-001)	ハリイタ 10 Needle Plate 10 (153022-001)	ハリイタ 12 Needle Plate 12 (156060-001)	ハリイタ 14 Needle Plate 14 (S09462-001)	ハリイタ 16 Needle Plate 16 (S09463-001)	ハリイタ 18 Needle Plate 18 (S09464-001)	ハリイタ 20 Needle Plate 20 (S09465-001)	

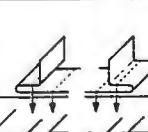
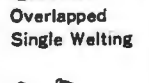
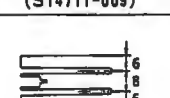
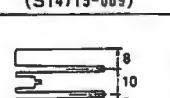
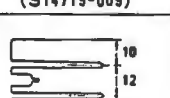
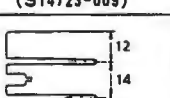
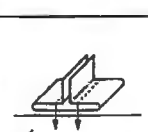
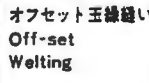
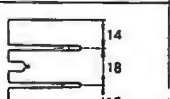
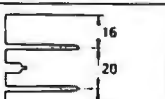
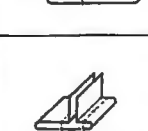
品名 Name of Parts	参照番号 Ref. No.	個数 Q'ty	針 巾 Needle Gauge						
			8 m/m	10m/m	12m/m	14m/m	16m/m	18m/m	20m/m
特別注文部品 Option Parts	セラミックコーナーメス (S) Ceramic Corner Knife (Small)	T-3-1	4	S14050-001			—		
	セラミックコーナーメス (L) Ceramic Corner Knife (Large)	T-3-2	4	—			S14051-001		

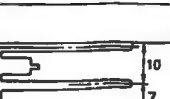
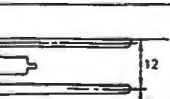
品名 Name of Parts	参照番号 Ref. No.	個数 Q'ty	t= 2 m/m	t= 3 m/m	t= 4 m/m	t= 5 m/m	t= 6 m/m
オオオサエゴム Carriage Feed Rubber	R-55	2	S08267-002	S08267-003	S08267-004	S08267-005	S08267-006

用途 Usage	参照番号 Ref. No.	個数 Q'ty	針 巾 / Needle Gauge						
			8 m/m	10m/m	12m/m	14m/m	16m/m	18m/m	20m/m
両玉縁縫い Double Welting  	R-54	1	 ジョウギクミ 8W Binder Assembly 8W (S14709-009)	 ジョウギクミ 10W Binder Assembly 10W (S14713-009)	 ジョウギクミ 12W Binder Assembly 12W (S14717-009)	 ジョウギクミ 14W Binder Assembly 14W (S14721-009)	 ジョウギクミ 16W Binder Assembly 16W (S14725-009)	 ジョウギクミ 18W Binder Assembly 18W (S14729-009)	 ジョウギクミ 20W Binder Assembly 20W (S14733-009)
			<薄物用-For thin materials>  	T-7	1	—	 B ジョウギクミ 10W B Binder Assembly 10W (S18577-009)	 B ジョウギクミ 12W B Binder Assembly 12W (S18579-009)	—
片玉縁縫い Single Welting  	R-54	1	 ジョウギクミ 8S Binder Assembly 8S (S14711-009)	 ジョウギクミ 10S Binder Assembly 10S (S14715-009)	 ジョウギクミ 12S Binder Assembly 12S (S14719-009)	 ジョウギクミ 14S Binder Assembly 14S (S14723-009)	 ジョウギクミ 16S Binder Assembly 16S (S14727-009)	 ジョウギクミ 18S Binder Assembly 18S (S14731-009)	 ジョウギクミ 20S Binder Assembly 20S (S14735-009)
			 	T-6	1	 C ジョウギクミ 8S C Binder Assembly 8S (S18906-009)	 C ジョウギクミ 10S C Binder Assembly 10S (S18908-009)	 C ジョウギクミ 12S C Binder Assembly 12S (S18910-009)	 C ジョウギクミ 14S C Binder Assembly 14S (S18912-009)
逆玉縁縫い Overlapped Single Welting  	T-8	1	—	—	—	—	—	 D ジョウギクミ 18S D Binder Assembly 18S (S18795-009)	 D ジョウギクミ 20S D Binder Assembly 20S (S18797-009)
			 	T-5	1	—	 OF ジョウギクミ Off-set Binder Assembly (S15602-009)	 OF ジョウギクミ Off-set Binder Assembly (S15604-009)	 OF ジョウギクミ Off-set Binder Assembly (S15606-009)